

# Linear drives DGC

**FESTO**



Festo core product range  
Covers 80% of your automation tasks

Worldwide:

Always in stock

Superb:

Festo quality at an attractive price

Easy:

Simplified procurement and warehousing

★ Generally ready for dispatch from the factory within 24 hours

In stock at 13 Service Centres worldwide

More than 2200 products

★ Generally ready for dispatch from the factory within 5 days

Assembled for you in 4 Service Centres worldwide

Up to  $6 \times 10^{12}$  variants per product family

Just look  
for the  
star!

## Characteristics

### At a glance

- Compact – installation length relative to stroke
- Loads and devices can be directly mounted on the slide.
- Three types of cushioning available:
  - Elastic cushioning
  - Pneumatic cushioning
  - Hydraulic cushioning
- All settings accessible from one side:
  - Precision end-position adjustment
  - Position of proximity sensors
  - Mounting of drive
  - Regulating speed
  - Pneumatic end-position cushioning
- Optional: NSF-H1 lubricant for the food area

The linear drive is of limited suitability for the food area.

Additional information:

[www.festo.com/sp](http://www.festo.com/sp)

→ Certificates

Not approved for use in the food area:

- DGC...-GP (protected version)
- DGC... with integrated shock absorbers

- Sealing system

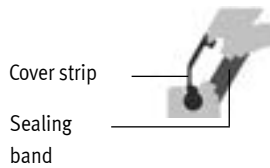

Advantages of the sealing system

- Long strokes with no restrictions
- Virtually no leakage

### Guide variants

#### Compact design DGC-K

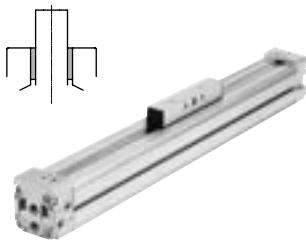

- Piston diameter 18 ... 80 mm
- Stroke lengths from 1 ... 8500 mm
- 30% narrower than the DGC-G
- Low moving dead weight
- Symmetrical design

#### Basic design DGC-G

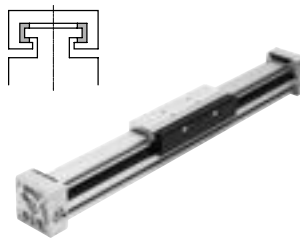

- Piston diameter 8 ... 63 mm
- Stroke lengths from 1 ... 8500 mm
- Guide backlash = 0.2 mm
- For small loads
- Operating behaviour under torque load = average

#### Plain-bearing guide DGC-GF

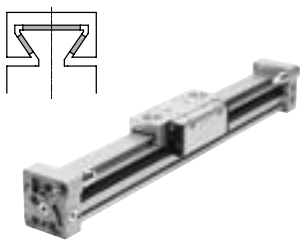

- Piston diameter 18 ... 63 mm
- Stroke lengths from 1 ... 8500 mm
- Guide backlash = 0.05 mm
- For small and medium loads
- Operating behaviour under torque load = average

#### Recirculating ball bearing guide DGC-KF

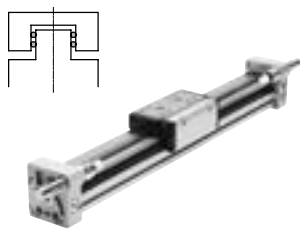

- Piston diameter 8 ... 63 mm
- Stroke lengths from 1 ... 8500 mm
- Guide backlash = 0 mm
- For medium and large loads
- Precision mounting interface with stainless steel slide
- Operating behaviour under torque load = very good

#### Heavy-duty guide DGC-HD

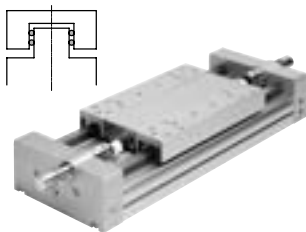

- Piston diameter 18, 25, 40 mm
- Stroke lengths from 10 ... 5000 mm
- Guide backlash = 0 mm
- For large loads
- Operating behaviour under torque load = very good

#### Guide axis DGC-FA

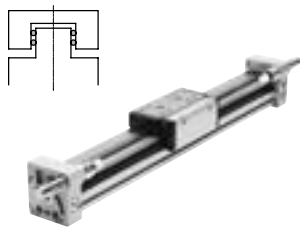

- Without drive
- Piston diameter 8 ... 63 mm
- Stroke lengths from 1 ... 8500 mm
- Guide backlash = 0 mm
- Precision guide, suitable for the DGC-KF. Can be used as machine component or as a twin guide with the DGC-KF

## Characteristics

### Versatility

#### [1] Compressed air supply ports

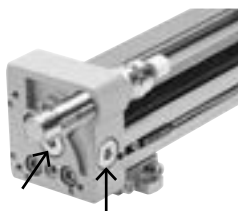

- Optionally on 2 sides (on the side or at the front)
- For DGC-G/DGC-GF/DGC-KF

#### DL – Compressed air supply port at the left end or at both ends

The linear drive is actuated at the right end or at both ends by default.

The linear drive can be actuated at the left end or at both ends by specifying the order code DL in the modular product system.

- For piston diameters 18, 25, 32, 40, 50, 63 mm
- For DGC-G, DGC-GF, DGC-KF

#### [2] G/H/I/I) – Proximity sensors

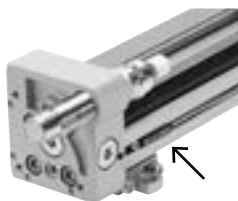

- Proximity sensors can be integrated, which means there is no projection. The cable can be guided through the slot behind the second sensor
- For DGC-G/DGC-GF/DGC-KF

#### [3] Precision end-position adjustment

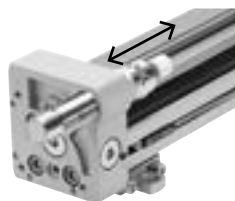

- Between 0 ... 25 mm per side
- For DGC-GF/DGC-KF/DGC-FA

#### [4] M – Profile mounting

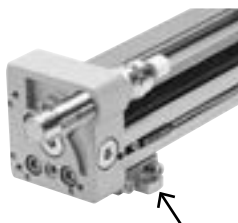

- Profile mounting remains on the base plate after the drive is dismantled. This means faster assembly and removal without repeat adjustment
- For DGC-G/DGC-GF/DGC-KF/DGC-FA

#### [5] YWZ – Mechanical end-position limiter

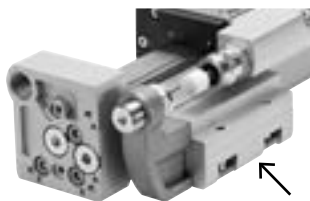

- For variable stroke adjustment, e.g. for format adjustments
- The end stop can be mounted at any position along the stroke
- For DGC-GF/DGC-KF/DGC-FA

#### [6] Z1/Z2/Z3 – Intermediate-position module

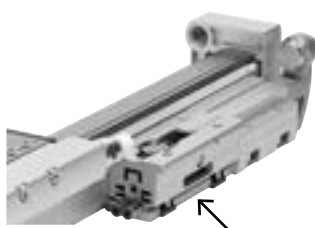

- Enables variable intermediate positions
- The intermediate-position module can be mounted at any place along the stroke
- Precision repetition accuracy (0.02 mm) with high dynamic response
- For DGC-KF

#### FK – Moment compensator



- Compensates for inaccuracies during mounting of the linear drive and external guide
- Max. offset 2.5 mm
- For DGC-G

### Example

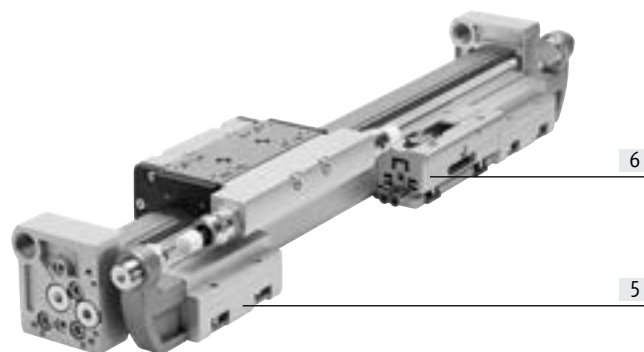
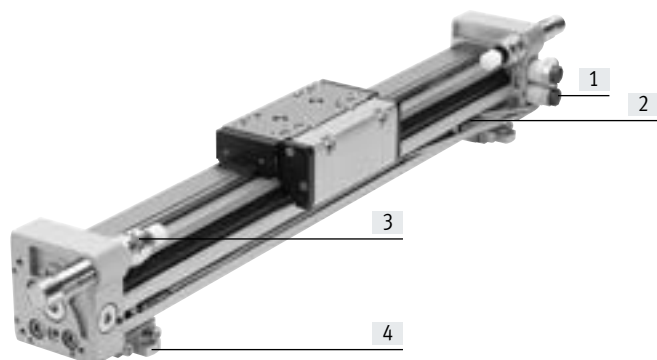

## Characteristics

### Options

#### C – Central lubrication

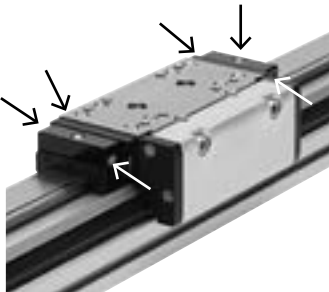

The lubrication adapters enable the guide of the linear drive DGC-KF to be permanently lubricated in applications in humid or wet ambient conditions using semi or fully automatic relubrication devices.

The adapters are suitable for oils and greases.

- For piston diameters 25, 32, 40, 63 mm
- For DGC-KF
- Connections:
  - On both sides of the slide
  - In three places (front, top, rear) on each side

Technical data → page 48

#### 1H-PN – Clamping unit

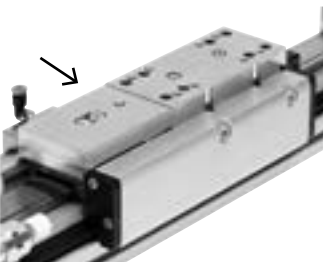





- 1-channel design, for holding loads
- Reliable holding is guaranteed since the forces act directly on the slide
- A limited number of emergency braking operations are permissible with the sizes 40 and 50

- For piston diameters 25, 32, 40, 50 mm
- For DGC-KF

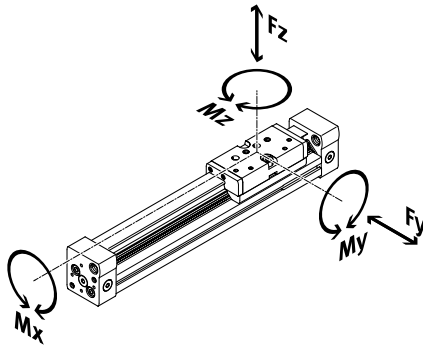
Technical data → page 45

## Characteristics

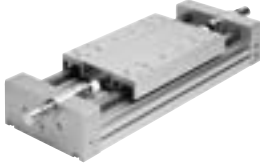
Product variants								
	Piston diameter	Theoretical force at 6 bar	Guide characteristics					→ Page/ Internet
	[mm]	[N]	Fy [N]	Fz [N]	Mx [Nm]	My [Nm]	Mz [Nm]	
<b>Compact design DGC-K</b>								
	18	153	–	120	0.8	11	1	dgc-k
	25	295	–	330	1.2	20	3	
	32	483	–	480	1.9	40	5	
	40	754	–	800	3.8	60	8	
	50	1178	–	1200	6	120	15	
	63	1870	–	1600	5.7	150	24	
	80	3016	–	2500	30.6	400	100	
<b>Basic design DGC-G</b>								
	8	30	150	150	0.5	2	2	8
	12	68	300	300	1.3	5	5	
	18	153	70	340	1.9	12	4	
	25	295	180	540	4	20	5	
	32	483	250	800	9	40	12	
	40	754	370	1100	12	60	25	
	50	1178	480	1600	20	150	37	
63	1870	650	2000	26	150	48		
<b>Plain-bearing guide DGC-GF</b>								
	18	153	440	540	3.4	20	8.5	22
	25	295	640	1300	8.5	40	20	
	32	483	900	1800	15	70	33	
	40	754	1380	2000	28	110	54	
	50	1178	1500	2870	54	270	103	
	63	1870	2300	4460	96	450	187	
<b>Recirculating ball bearing guide DGC-KF</b>								
	8	30	300	300	1.7	4.5	4.5	40
	12	68	650	650	3.5	10	10	
	18	153	1850	1850	16	51	51	
	25	295	3050	3050	36	97	97	
	32	483	3310	3310	54	150	150	
	40	754	6890	6890	144	380	380	
	50	1178	6890	6890	144	634	634	
	63	1870	15200	15200	529	1157	1157	
<b>Heavy-duty guide DGC-HD</b>								
	18	153	3650	3650	140	275	275	dgc-hd
	25	295	5600	5600	300	500	500	
	40	754	13000	13000	900	1450	1450	

## Type codes

<b>001</b>	<b>Series</b>	
<b>DGC</b>	Linear drive	
<b>002</b>	<b>Piston diameter</b>	
<b>8</b>	8	
<b>12</b>	12	
<b>18</b>	18	
<b>25</b>	25	
<b>32</b>	32	
<b>40</b>	40	
<b>50</b>	50	
<b>63</b>	63	
<b>003</b>	<b>Stroke</b>	
<b>...</b>	1 ... 8500	
<b>004</b>	<b>Guide</b>	
<b>G</b>	Basic variant	
<b>GF</b>	Plain bearing	
<b>KF</b>	Recirculating ball bearing guide	
<b>FA</b>	Passive guide axis	
<b>005</b>	<b>Cushioning</b>	
<b>P</b>	Elastic cushioning rings/plates on both sides	
<b>PPV</b>	Pneumatic cushioning, adjustable at both ends	
<b>YSR</b>	Self-adjusting shock absorber	
<b>YSRW</b>	Shock absorber, self-adjusting, progressive	
<b>006</b>	<b>Position sensing</b>	
<b>A</b>	For proximity sensor	
<b>007</b>	<b>Compressed air connection</b>	
	At the right end or at both ends	
<b>DL</b>	At the left or at both ends	
<b>008</b>	<b>Lubrication</b>	
	Standard	
<b>H1</b>	Food-safe lubrication	
<b>009</b>	<b>Slide</b>	
	Standard	
<b>GP</b>	Protected recirculating ball bearing guide	
<b>010</b>	<b>Lubrication function</b>	
	None	
<b>C</b>	Lubrication adapter	
<b>011</b>	<b>Additional slide left</b>	
	None	
<b>KL</b>	Additional slide, standard, left	
<b>012</b>	<b>Additional slide, right</b>	
	None	
<b>KR</b>	Additional slide standard, right	
<b>013</b>	<b>Clamping unit</b>	
	None	
<b>1H</b>	Holding function, 1-channel	

<b>014</b>	<b>Actuation type</b>	
	None	
<b>PN</b>	Pneumatically actuated	
<b>015</b>	<b>EU certification</b>	
	None	
<b>EX2</b>	II 3GD	
<b>EX3</b>	II 2G	
<b>016</b>	<b>Accessories</b>	
	None	
<b>ZUB</b>	Accessories supplied loose	
<b>017</b>	<b>Foot mounting</b>	
	None	
<b>F</b>	1 record	
<b>018</b>	<b>Profile mounting</b>	
	None	
<b>...M</b>	1 ... 9 pieces	
<b>019</b>	<b>Slot nut, mounting slot</b>	
	Without	
<b>...B</b>	1 ... 9 pieces	
<b>020</b>	<b>Moment compensator</b>	
	None	
<b>FK</b>	Moment compensator	
<b>021</b>	<b>Proximity switch, cable 2.5 m</b>	
	None	
<b>...G</b>	1 ... 9 pieces	
<b>022</b>	<b>Proximity switch, plug M8</b>	
	None	
<b>...H</b>	1 ... 9 pieces	
<b>023</b>	<b>Proximity switch, contactless, cable 2.5 m</b>	
	None	
<b>...I</b>	1 ... 9 pieces	
<b>024</b>	<b>Proximity switch, contactless, plug M8</b>	
	None	
<b>...J</b>	1 ... 9 pieces	
<b>025</b>	<b>Connecting cable, M8, 2.5 m</b>	
	None	
<b>...V</b>	1 ... 9 pieces	
<b>026</b>	<b>Slot cover, sensor slot</b>	
	Without	
<b>...L</b>	1 ... 9 pieces	
<b>027</b>	<b>Mechanical end position limitation</b>	
	None	
<b>YWZ1</b>	Variable end position, one side	
<b>YWZ2</b>	Variable end position, both sides	

## Type codes

<b>028</b>	<b>Intermediate position</b>	
	None	
<b>Z1</b>	1 intermediate position	
<b>Z2</b>	2 intermediate positions	
<b>Z3</b>	3 intermediate positions	

<b>029</b>	<b>Operating instructions</b>	
	Standard	
<b>0</b>	Express waiver - no operating instructions to be included as already available (operating instructions in PDF format are available free of charge on our website at <a href="http://www.festo.com">http://www.festo.com</a> )	

## Peripherals overview



### DGC-8/-12

 **Note**

1) Operation without cushioning components is not permitted.

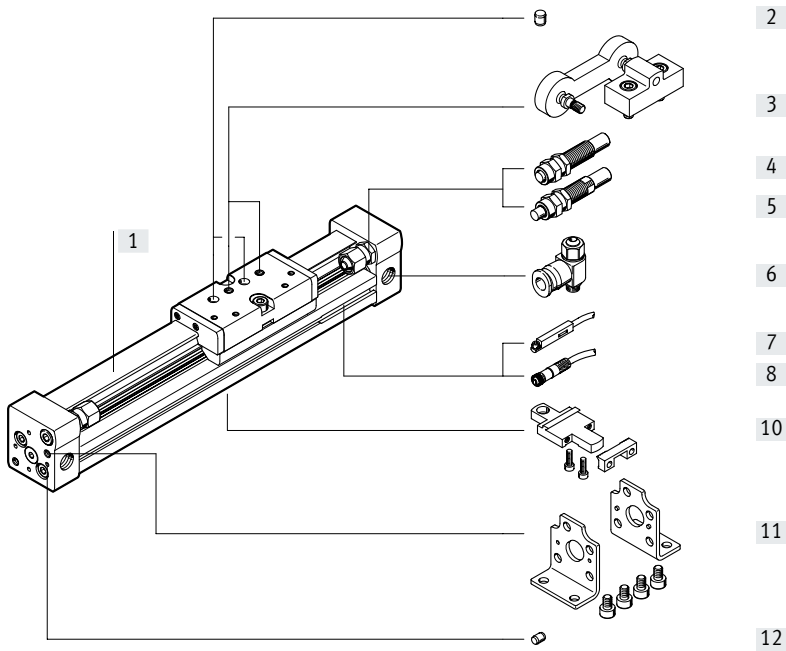

### DGC-18 ... 63

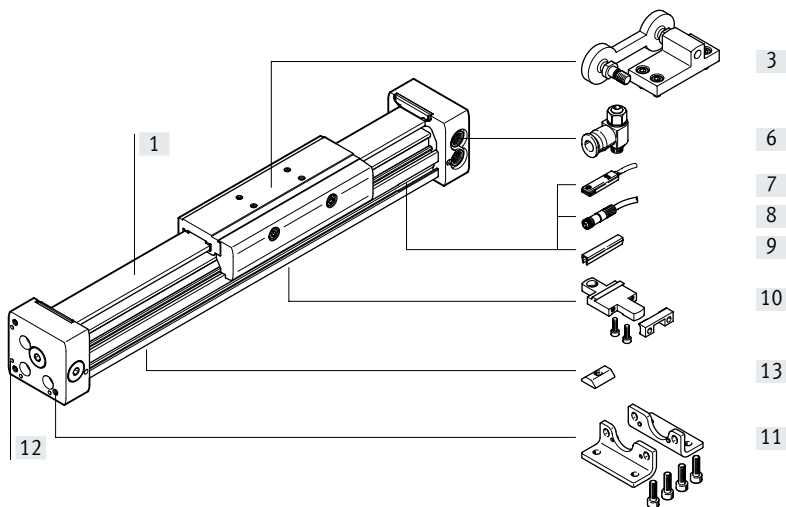

## Peripherals overview

Variants and accessories			
Type/order code	For piston diam.	Description	→ Page/Internet
[1] Linear drive DGC-G	8 ... 63	Linear drive without accessories, basic design	10
[2] Centring pin <sup>1)</sup> ZBS	8, 12	For centring loads and attachments on the slide	74
[3] Moment compensator FK	8 ... 63	Compensates for inaccuracies during mounting of the linear drive and external guide	68
– Cushioning P	8, 12	Non-adjustable, elastic cushioning. Used only at low speeds.	21
– Cushioning PPV	18 ... 63	Adjustable, pneumatic end-position cushioning. Used at medium speeds.	21
[4] Shock absorber YSR	8, 12	Self-adjusting, hydraulic shock absorber with spring return and linear cushioning characteristics.	21
[5] Shock absorber YSRW	8, 12	Self-adjusting, hydraulic shock absorber with spring return and progressive cushioning characteristics	21
[6] One-way flow control valve GRLA	8 ... 63	For regulating speed	75
[7] Proximity sensor G/H/I/J	8 ... 63	For sensing the slide position	75
[8] Connecting cable V	8 ... 63	For proximity sensor	76
[9] Slot cover L	18 ... 63	For protecting against contamination and securing the proximity sensor cable in place	74
[10] Profile mounting M	8 ... 63	Simple and precise mounting option via dovetail connection.	66
[11] Foot mounting F	8 ... 63	For mounting on the end cap	64
[12] Centring pin/sleeve ZBS/ZBH	8, 12, 50, 63	For centring the drive without foot mountings (user-specific)	74
[13] Slot nut B	25 ... 63	For mounting attachments	74

1) Included in the scope of delivery of the drive

Data sheet

Function

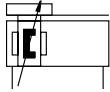

www.festo.com

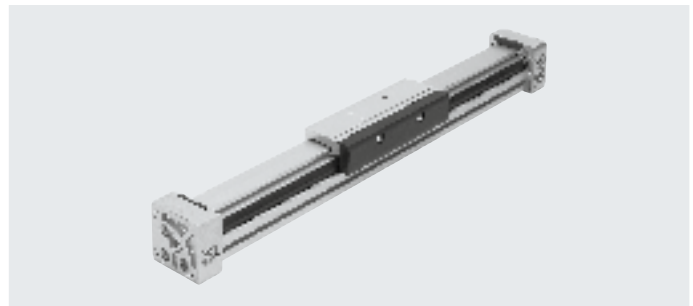

- Diameter  
8 ... 63 mm
- Stroke length  
1 ... 8500 mm

General technical data		8	12	18	25	32	40	50	63
Piston diameter		8	12	18	25	32	40	50	63
Design		Rodless drive							
Moment compensator principle		Slotted cylinder, mechanically coupled							
Guide		Basic design							
Mode of operation		Double-acting							
Stroke	[mm]	1 ... 1500	1 ... 2000	1 ... 3000	1 ... 8500			1 ... 5000	
Pneumatic connection		M5			G1/8		G1/4	G3/8	
Cushioning → page 1									
DGC...-P		Non-adjustable at both ends		-					
DGC...-PPV		-		Adjustable at both ends					
DGC...-YSR...		Self-adjusting at both ends		-					
Cushioning length with cushioning PPV	[mm]	-		16.5	15.5	17.5	29.5	29.8	31.1
Max. speed	[m/s]	1	1.2	3					
Position sensing		Via proximity sensor							
Type of mounting		Profile mounting							
		Foot mounting							
		Direct mounting							
Mounting position		Any							

† Note: This product conforms to ISO 1179-1 and ISO 228-1.

Operating and environmental conditions		8	12	18	25	32	40	50	63
Piston diameter		8	12	18	25	32	40	50	63
Operating pressure	[bar]	2.5 ... 8		2 ... 8			1.5 ... 8		
Operating medium		Compressed air to ISO 8573-1:2010 [7:-:-]							
Note on operating/pilot medium		Lubricated operation possible (in which case lubricated operation will always be required)							
Ambient temperature <sup>1)</sup>	[°C]	+5 ... +60	-10 ... +60						
Food-safe <sup>2)</sup>		-		→ supplementary information on materials					
Corrosion resistance class CRC <sup>3)</sup>		2							

1) Note operating range of proximity sensors

2) Additional information is available at [www.festo.com/sp](http://www.festo.com/sp) → Certificates.

3) Corrosion resistance class CRC 2 to Festo standard FN 940070

Moderate corrosion stress. Indoor applications in which condensation can occur. External visible parts with primarily decorative surface requirements which are in direct contact with a normal industrial environment.

Forces [N] and impact energy [J]		8	12	18	25	32	40	50	63
Piston diameter		8	12	18	25	32	40	50	63
Theoretical force at 6 bar		30	68	153	295	483	754	1178	1870
Impact energy at the end positions		→ page 1							

## Data sheet

<b>ATEX<sup>1)</sup></b>		
Size	8	12 ... 63
Explosion-proof ambient temperature [°C]	+5°C ≤ Ta ≤ +60°C	-10°C ≤ Ta ≤ +60°C
CE marking (see declaration of conformity)	To EU Explosion Protection Directive (ATEX)	
<b>EX2 certification</b>		
ATEX category for gas	II 3G	
Type of ignition protection for gas	Ex h IIC T4 Gc X	
ATEX category for dust	II 3D	
Type of ignition protection for dust	Ex h IIIC T120°C Dc X	
<b>EX3 certification</b>		
ATEX category for gas	II 2G	
Type of ignition protection for gas	Ex h IIC T4 Gb X	

1) Note the ATEX certification of the accessories.

<b>Weight [g]</b>								
Piston diameter	8	12	18	25	32	40	50	63
Basic weight with 0 mm stroke	170	290	546	1004	2126	4121	9050	14040
Additional weight per 10 mm stroke	9	12	22	34	54	77	116	150
Moving mass	36	65	178	287	508	1312	2850	4330

## Adjustable end-position range d [mm]

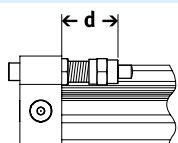

Piston diameter	8	12
Cushioning		
DGC-...YSR/YSRW	12.8 ... 22.8	14 ... 24

## Materials

Sectional view

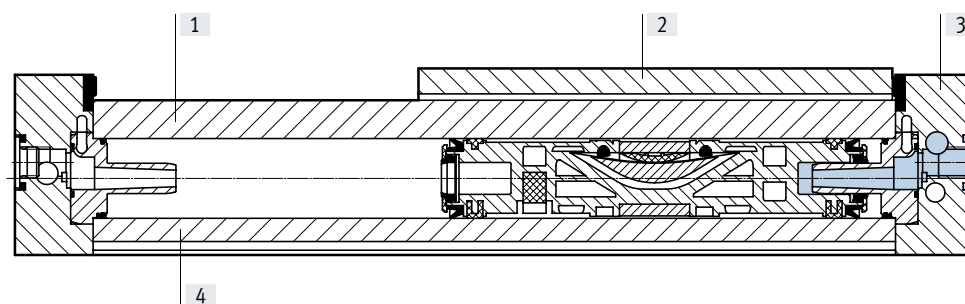

<b>Linear drives</b>		
[1]	Guide rail	Anodised aluminium
[2]	Slide	Anodised aluminium
[3]	End cap	Anodised aluminium
[4]	Cylinder barrel	Anodised aluminium
-	Piston seal	Polyurethane
	Sealing band/cover strip	Polyurethane
	Slide elements	Polyacetal
	Note on materials	RoHS-compliant

## Data sheet

### Characteristic load values

The indicated forces and torques refer to the centre of the slide surface. These values must not be exceeded during dynamic operation. Special attention must be paid to the deceleration phase.

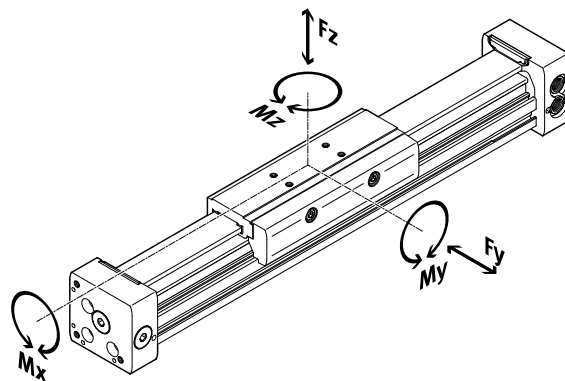

**Note**  
To prevent the guide of the basic drive DGC-G from self-locking when used vertically and with a high torque load, the variant with the recirculating ball bearing guide DGC-KF → page 40 is recommended.

If the drive is subjected to two or more of the indicated forces and torques simultaneously, the following equation must be satisfied in addition to the indicated maximum loads:

$$\frac{F_y}{F_{y_{max}}} + \frac{F_z}{F_{z_{max}}} + \frac{M_x}{M_{x_{max}}} + \frac{M_y}{M_{y_{max}}} + \frac{M_z}{M_{z_{max}}} \leq 1$$

Permissible forces and torques		8	12	18	25	32	40	50	63
Piston diameter		8	12	18	25	32	40	50	63
$F_{y_{max}}$	[N]	150	300	70	180	250	370	480	650
$F_{z_{max}}$	[N]	150	300	340	540	800	1100	1600	2000
$M_{x_{max}}$	[Nm]	0.5	1.3	1.9	4	9	12	20	26
$M_{y_{max}}$	[Nm]	2	5	12	20	40	60	150	150
$M_{z_{max}}$	[Nm]	2	5	4	5	12	25	37	48

### Influence of ferritic materials on proximity sensors

Ferritic materials (steel parts or sheet metal) in the immediate vicinity of the proximity sensors can cause sensing malfunctions. The following safety distances must be observed.

The distance depends on the position of the proximity sensor (see [1] and [2]).

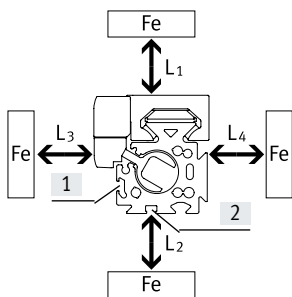

Piston diameter		8	12	18	25	32	40	50	63
Distance L1	[1] [mm]	0	0	0	0	0	0	0	0
	[2] [mm]	-	-	0	0	0	0	0	0
Distance L2	[1] [mm]	20	10	10	10	0	0	0	0
	[2] [mm]	-	-	25	25	25	25	25	25
Distance L3	[1] [mm]	30	25	25	25	25	25	25	25
	[2] [mm]	-	-	10	10	0	0	0	0
Distance L4	[1] [mm]	0	0	0	0	0	0	0	0
	[2] [mm]	-	-	0	0	0	0	0	0

## Data sheet

### Maximum permissible speed $v$ as a function of payload $m$ and distance $r_{max}$ from centre of mass

Piston diameter 8/12 with cushioning P

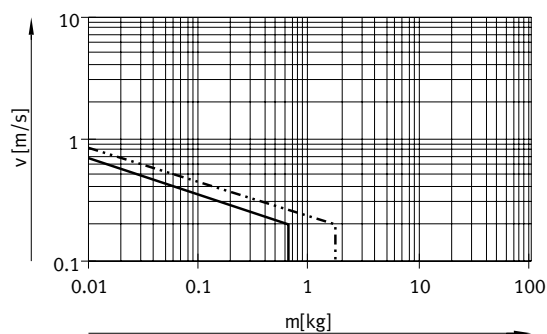

Piston diameter 18 ... 63 with cushioning PPV

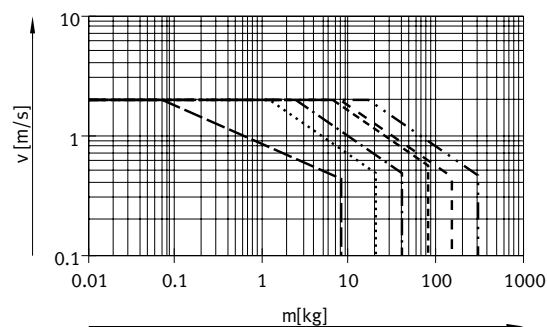

Piston diameter 8/12 with cushioning YSR

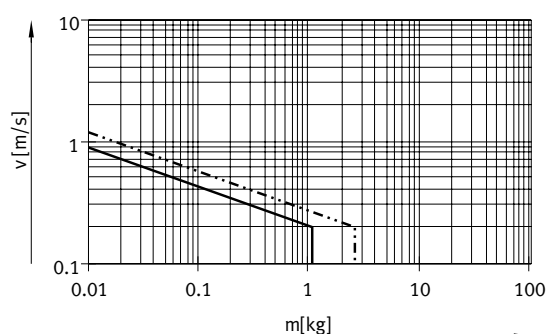

Piston diameter 8/12 with cushioning YSRW

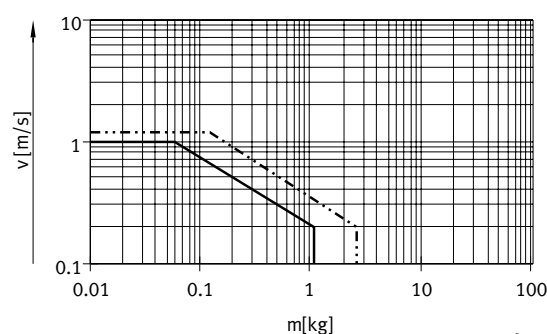

- $\varnothing$  8
- · - · -  $\varnothing$  12
- - -  $\varnothing$  18
- · · · ·  $\varnothing$  25
- · - · -  $\varnothing$  32
- - -  $\varnothing$  40
- - -  $\varnothing$  50
- · - · -  $\varnothing$  63

#### Note

These specifications represent the maximum values that can be achieved. In practice, these values can fluctuate dependent on the position of the payload and mounting position.

### Operating range of the cushioning

The end-position cushioning must be adjusted to ensure jerk-free operation. If the operating conditions are outside the permissible range, the moving mass must be cushioned using suitable equipment (external shock absorbers), preferably at the centre of mass.

#### Note

To avoid distortion in the slide, the bearing surfaces of the attachments must maintain a flatness of at least 0.03 mm.

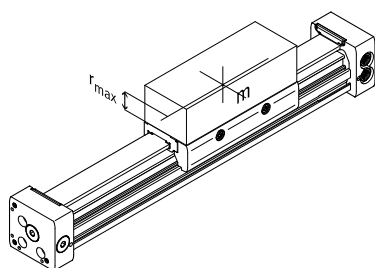

Data for horizontal mounting position:

Piston diameter	8	12	18	25	32	40	50	63
Distance $r_{max}$ [mm]	25	35	35	50	50	50	50	50

## Data sheet

### Number of profile mountings MUC as a function of weight force F and distance l between supports

In order to limit deflection in the case of large strokes, the drive may need to be supported. The following graphs are provided to determine the maximum permissible distance between supports as a function of the mounting position and the applied weight and normal forces.

#### Horizontal mounting position

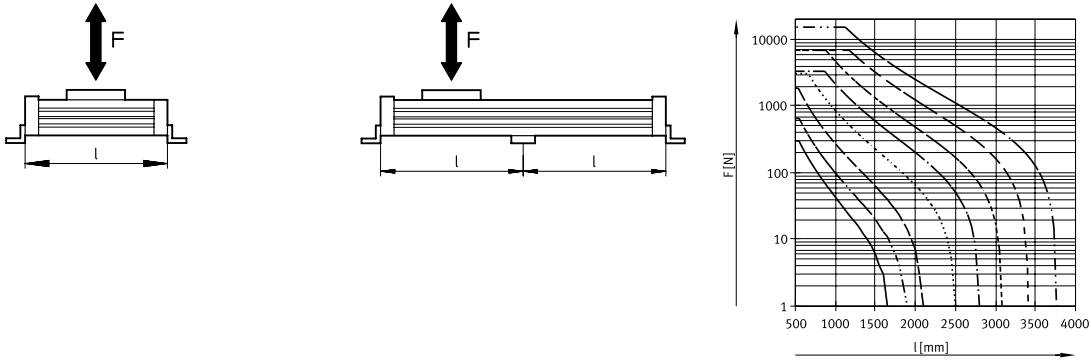

#### Vertical mounting position

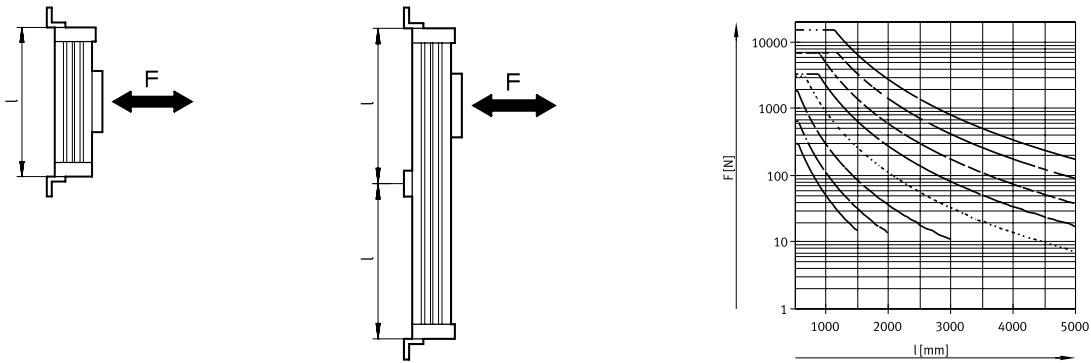

#### Example:

The drive DGC-25-1500 is subjected to a force of 300 N in a horizontal mounting position.

The drive has an overall length of:  
 $l = \text{stroke length} + L1$   
 (see dimensions)  
 $= 1500 \text{ mm} + 200 \text{ mm}$   
 $= 1700 \text{ mm}$

According to the graph, the max. distance between supports for the drive DGC-25 with a force of 300 N is 1300 mm.

In this example, profile mountings are required as the max. distance between supports (1300 mm) is smaller than the overall length of the drive (1700 mm).

Data sheet

Dimensions

Download CAD data → [www.festo.com](http://www.festo.com)

∅ 8 and 12

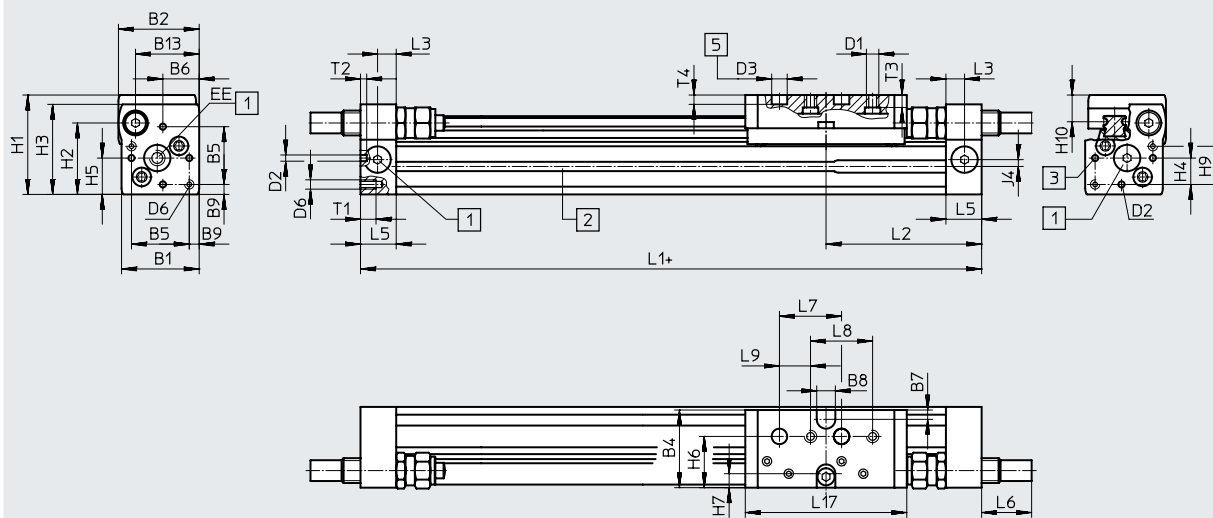

+ = plus stroke length

[1] Compressed air supply port options on 3 sides

[2] Sensor slot for proximity sensor

[3] Mounting hole for foot mounting or centring pin

[5] Drilled hole for centring pin ZBS

∅	B1	B2	B4	B5	B6	B7	B8	B9	B13	D1	D2	D3	D6
[mm]							±0.05	±0.1			∅ H8	∅ H7	
8	25	26	25.5	18.6	11.7	3	6	3.2	20.5	M4	2	5	M3
12	30.2	31	30.5	20.6	13.5	3	8	4.8	25	M4	2	5	M4

∅	EE	H1	H2	H3	H4	H5	H6	H7	H9	H10	J4	L1	L2
[mm]													
8	M5	32	23	29	8.5	11.7	16.5	4.5	12.3	8.7	2.2	100	50.1
12	M5	37.5	28.5	34.5	8.7	13.5	20.5	5	14.7	9.8	3	125	62.4

∅	L3	L5	L6			L7	L8	L9	L17	T1	T2	T3	T4	Stroke tolerance
			P	YSR	YSRW									
[mm]						±0.03	±0.1	±0.1					+0.2	
8	6	11.4	0	16	16.2	20	20	10	52	5	2	4	3	0 ... 1.7
12	8	15.9	0	11.3	12.3	20	20	10	65	6	2	5	3	

Length tolerance

For stroke [mm]

≤ 1000

≤ 2000

L1 [mm]

+0.90

+1.10

Profile barrel

∅ 8

∅ 12

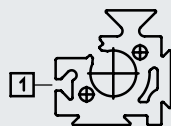
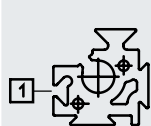

[1] Sensor slot for proximity sensor

Data sheet

Dimensions

Download CAD data → [www.festo.com](http://www.festo.com)

∅ 18 ... 40

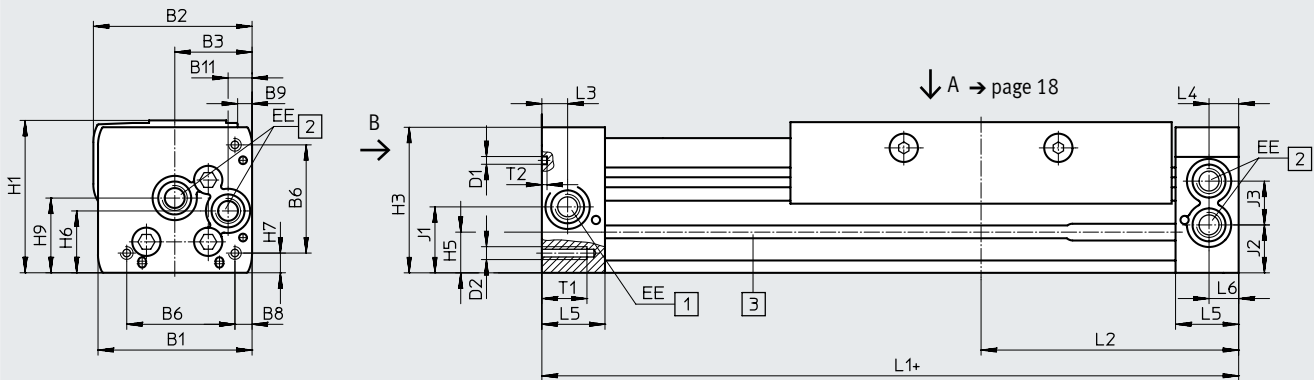

View B  
∅ 18

∅ 25 ... 40

∅ 18 ... 40

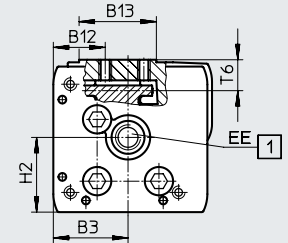
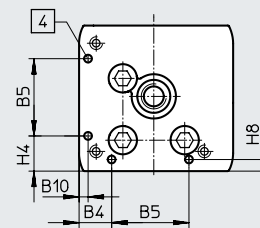
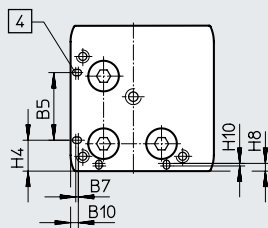

∅ 50/63

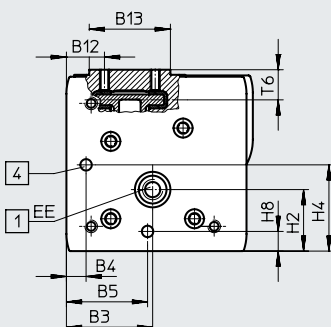
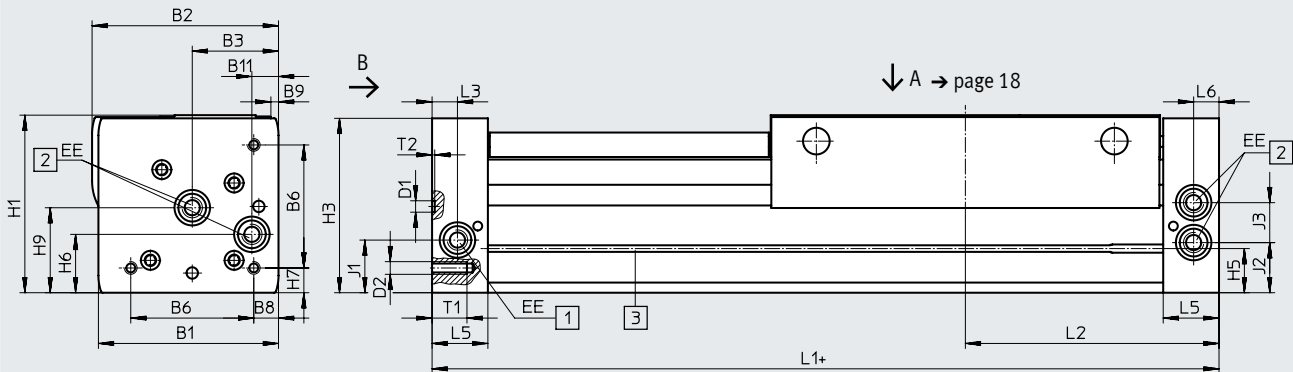

+ = plus stroke length

- [1] Compressed air supply port options on 2 sides
- [2] Compressed air supply port options on 2 sides, for compressed air supply port at one end
- [3] Sensor slot for proximity sensor
- [4] Mounting hole for foot mounting HPC

 **Note**

The linear drive is actuated at the right end or at both ends by default.  
The linear drive can be actuated at the left end or at both ends by specifying the order code DL in the modular product system.

Data sheet

∅	B1	B2	B3	B4	B5	B6	B7	B8	B9	B10
[mm]					±0.05					
18	44.5	46.3	19.5	8.8	21	31	0.3	3.8	3.3	2.4
25	59.8	61.6	30	12.65	30	42		6.65	5.6	3.5
32	73	75.5	38.5	5.7	63.1	57.5		8.5	5	14
40	91	94.5	45	17.2	55	65		12.2	5.3	8
50	113	122	60	8	52.8	81.6	–	12	0	–
63	142	147	68	15.5	68	97	–	19.5	6	–

∅	B11	B12	B13	D1	D2	EE	H1	H2	H3	H4
[mm]				∅						±0.2
18	5.5	19.3	20	2±0.05	M4	M5 G1/8 G1/8 G1/4 G1/4 G3/8	49.8	23.1	48.3	10.3
25	9.3	20.15	30	3±0.05	M5		58.5	29	56.5	13
32	14.9	20.5	35	3±0.05	M6		73	30	71.5	5.7
40	16.5	19.8	45	4±0.05	M6		88	41.5	85	17.2
50	21	24	64	9 <sup>H7</sup>	M8		120	38.5	116	52.8
63	21	30	64	9 <sup>H7</sup>	M10		140	48.5	137.5	68

∅	H5	H6	H7	H8	H9	H10	J1	J2	J3	L1
[mm]										
18	13.4	20	5.3	2.4	25.2	0.4	20	16.5	11	150
25	15.8	24	7	4.5	29		26.1	18.6	17	200
32	17	27.7	8.5	14	35.2		30	22	18.5	250
40	25	36.5	12.2	8	44		35	26	26	300
50	29.3	36	12	8	53	–	30.5	30.5	28	350
63	34.8	46	19.5	15.5	67	–	41.5	39.5	31.5	400

∅	L2	L3	L4	L5	L6	T1	T2	T6	Stroke tolerance
[mm]									
18	74.5	5.7	5.8	15	5.5	9	2	10.7	0 ... 2.5
25	100	10.5	10.6	24.5	10.6	17.5	2	12	
32	124.8	14.5	14.5	30.5	14.5	15	2	13.8	
40	150	14.6	14.6	33.5	14.6	20	3	16.8	
50	175	17	–	41	17	24	2.1 <sup>+0.2</sup>	20.75	
63	200	20	–	44	20	27.5	2.1 <sup>+0.2</sup>	20.75	



**Note**

This product conforms to ISO 1179-1 and ISO 228-1.

Length tolerance		≤ 1000	≤ 2000	≤ 3000	≤ 4000	≤ 5000	≤ 6000	≤ 7000	≤ 8000	≤ 9000
For stroke	[mm]									
L1	[mm]	+0.90	+1.10	+1.40	+1.50	+1.60	+1.70	+2.20	+2.30	+2.40

Data sheet

Dimensions

Download CAD data → [www.festo.com](http://www.festo.com)

Slide – View A

∅ 18

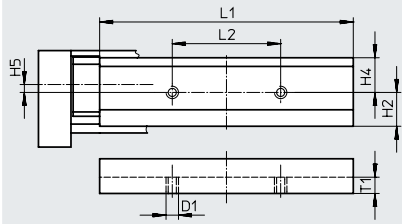

∅ 25

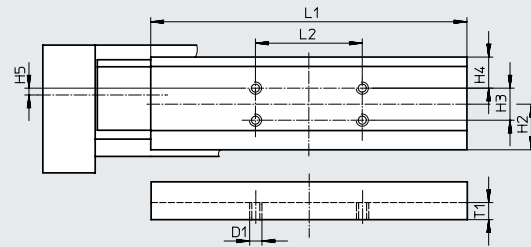

∅ 32

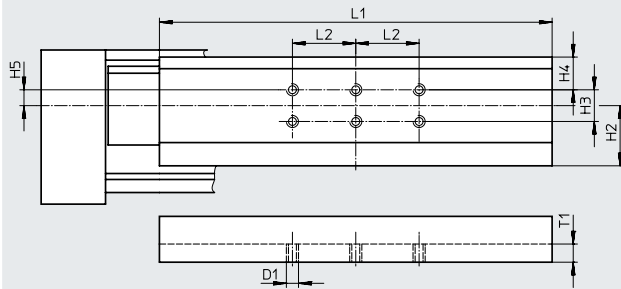

∅ 40

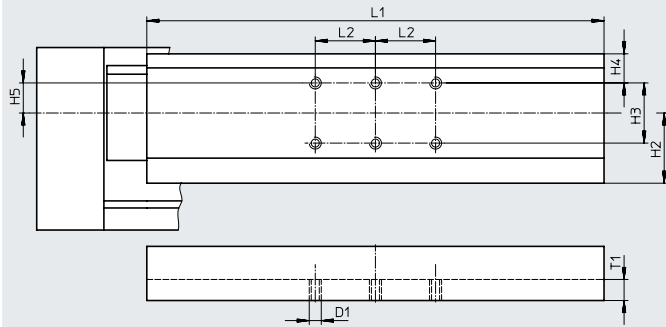

∅ 50

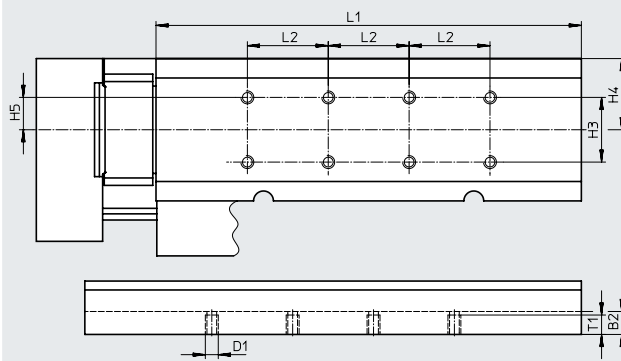

Data sheet

Dimensions

Download CAD data → [www.festo.com](http://www.festo.com)

Slide – View A

∅ 63

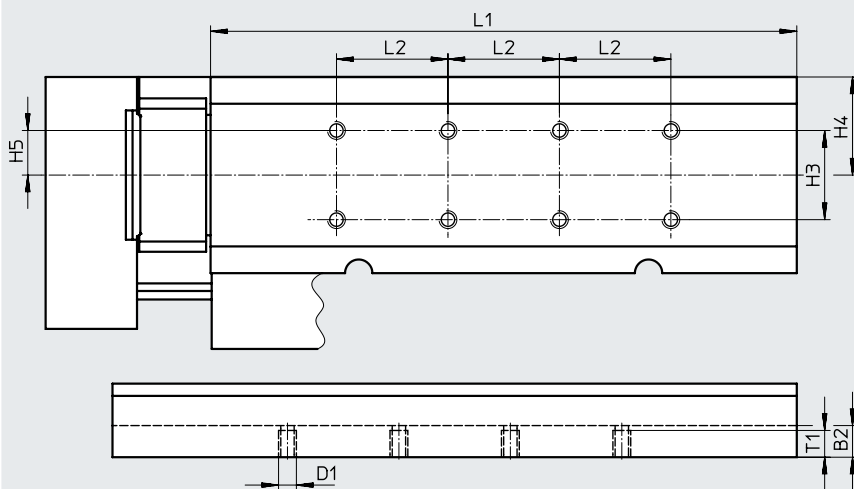

∅ [mm]	B2	D1	H2 ±0.1	H3 ±0.1	H4	H5	L1	L2 ±0.1	T1
18	-	M5	15.6	-	16	2	117±0.05	50	7
25	-	M5	21.35	15	14.55	4.85	148±0.05	50	8
32	-	M5	28.5	15	15.5	7.5	186±0.05	30	8.6
40	-	M6	35	30	14.5	15	228±0.05	30	10.5
50	14	M8	-	40	44	20	263±0.1	50	13
63	14	M8	-	40	44	20	307±0.1	50	13

Profile barrel

∅ 18

∅ 25

∅ 32

∅ 40

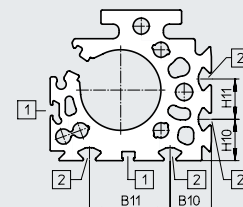
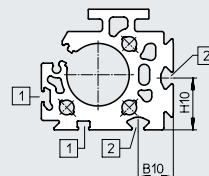
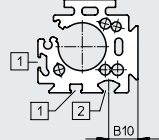
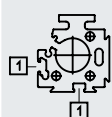

∅ 50

∅ 63

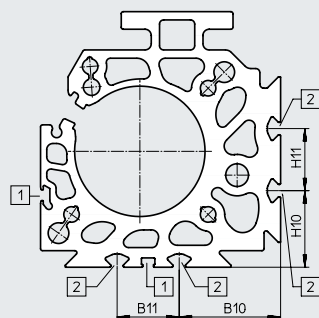
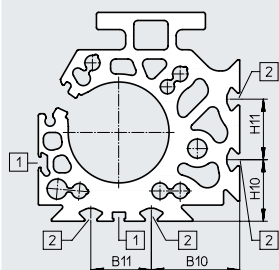

- [1] Sensor slot for proximity sensor
- [2] Mounting slot for slot nut

∅ [mm]	B10	B11	H10	H11
25	15.23	-	-	-
32	18	-	26.5	-
40	20.5	40	20.5	20
50	43.8	30	30.5	30
63	49	30	37	30

## Ordering data – Modular product system

**Order code**  
DGC-8/-12

 **Note**

1) End stops or shock absorbers must not be removed.

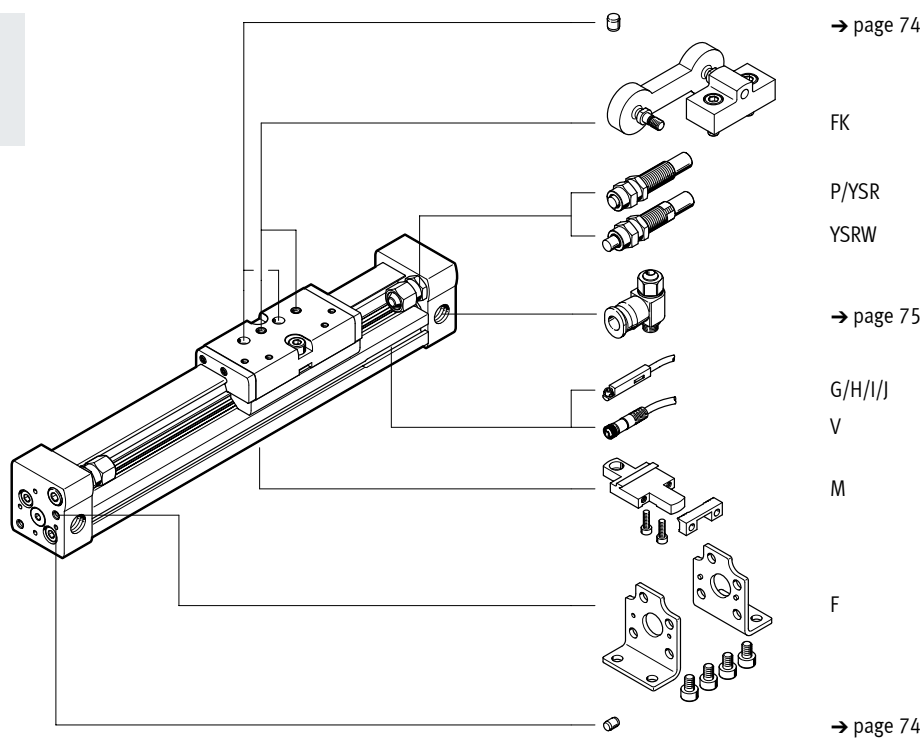

DGC-18 ... 63

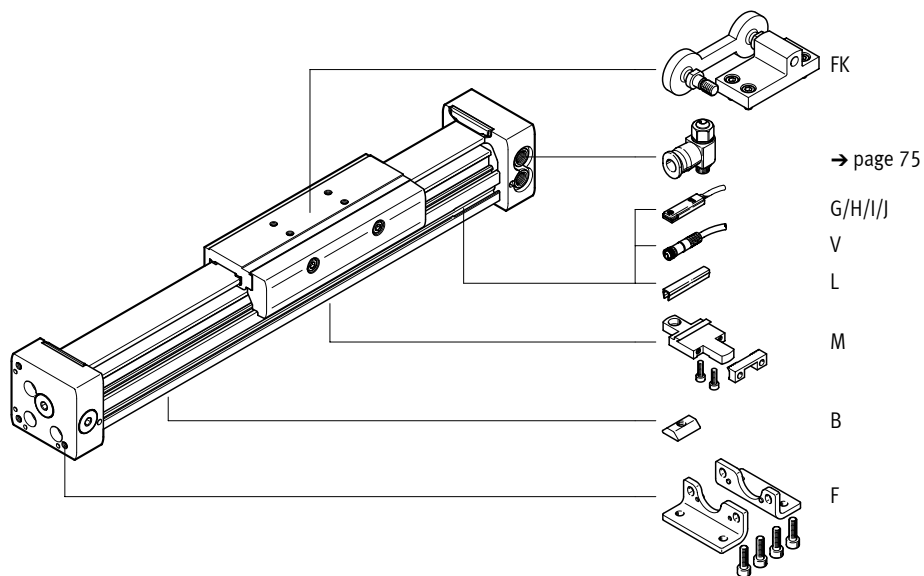

### Ordering data – Modular product system

Ordering table												
Size	8	12	18	25	32	40	50	63	Condi- tions	Code	Enter code	
Module no.	<b>530906</b>	<b>530907</b>	<b>532446</b>	<b>532447</b>	<b>532448</b>	<b>532449</b>	<b>532450</b>	<b>532451</b>				
Function	Linear drive									DGC	DGC	
Piston diam. [mm]	8	12	18	25	32	40	50	63		★ -...		
Stroke [mm]	1 ... 1500	1 ... 2000	1 ... 3000	1 ... 8500			1 ... 5000			★ -...		
Guide	Basic design									★ -G	-G	
Cushioning	At both ends	Elastic cushioning rings/ plates		-	-	-	-	-	-	★ -P		
	Adjustable at both ends	-	-	Pneumatic cushioning						★ -PPV		
	Self-adjusting	Shock absorber		-	-	-	-	-	-	-YSR		
		Shock absorber, progressive		-	-	-	-	-	-	★ -YSRW		
Position sensing	Via proximity sensor									★ -A	-A	
Compressed air supply port	At the right end or at both ends									★		
	-	-	At the left end or at both ends						-DL			
Lubrication	-	-	Standard						★			
	-	-	Lubrication approved for use in food applications						-H1			
EU certification	Without									★		
	II 3GD									[1]	-EX2	
	II 2G									[1]	-EX3	
Accessories	Enclosed separately (can be retrofitted)									ZUB-	ZUB-	
Foot mounting	1									F		
Profile mounting	1 ... 9									...M		
Moment compensator	Without											
	Moment compensator coupling									FK		
Slot nut for mounting slot	-	-	-	1 ... 9					...B			
Proximity sensor	2.5 m cable	1 ... 9									...G	
	Plug M8	1 ... 9									...H	
Proximity sensor, contactless, PNP	2.5 m cable	1 ... 9									...I	
	Plug M8	1 ... 9									...J	
Connecting cable	M8, 2.5 m	1 ... 9									...V	
Slot cover for sensor slot	-	-	1 ... 9						...L			
Operating instructions	Express waiver – no operating instructions to be included (already available)									-O		

[1] EX2, EX3 Not with moment compensator FK, proximity sensor G, H, I, J, connecting cable V

Festo core product range



Generally ready for dispatch from the factory within 24 hours  
 Generally ready for dispatch from the factory within 5 days

Peripherals overview

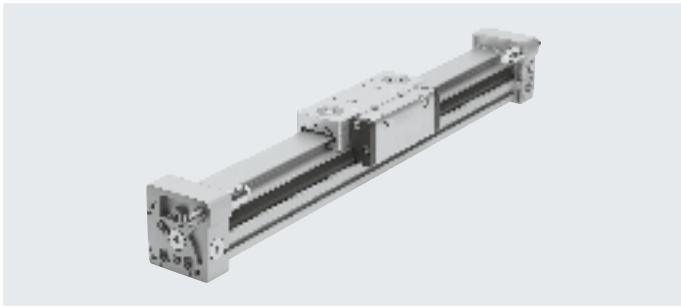

 **Note**  
 1) Operation without cushioning components is not permitted.

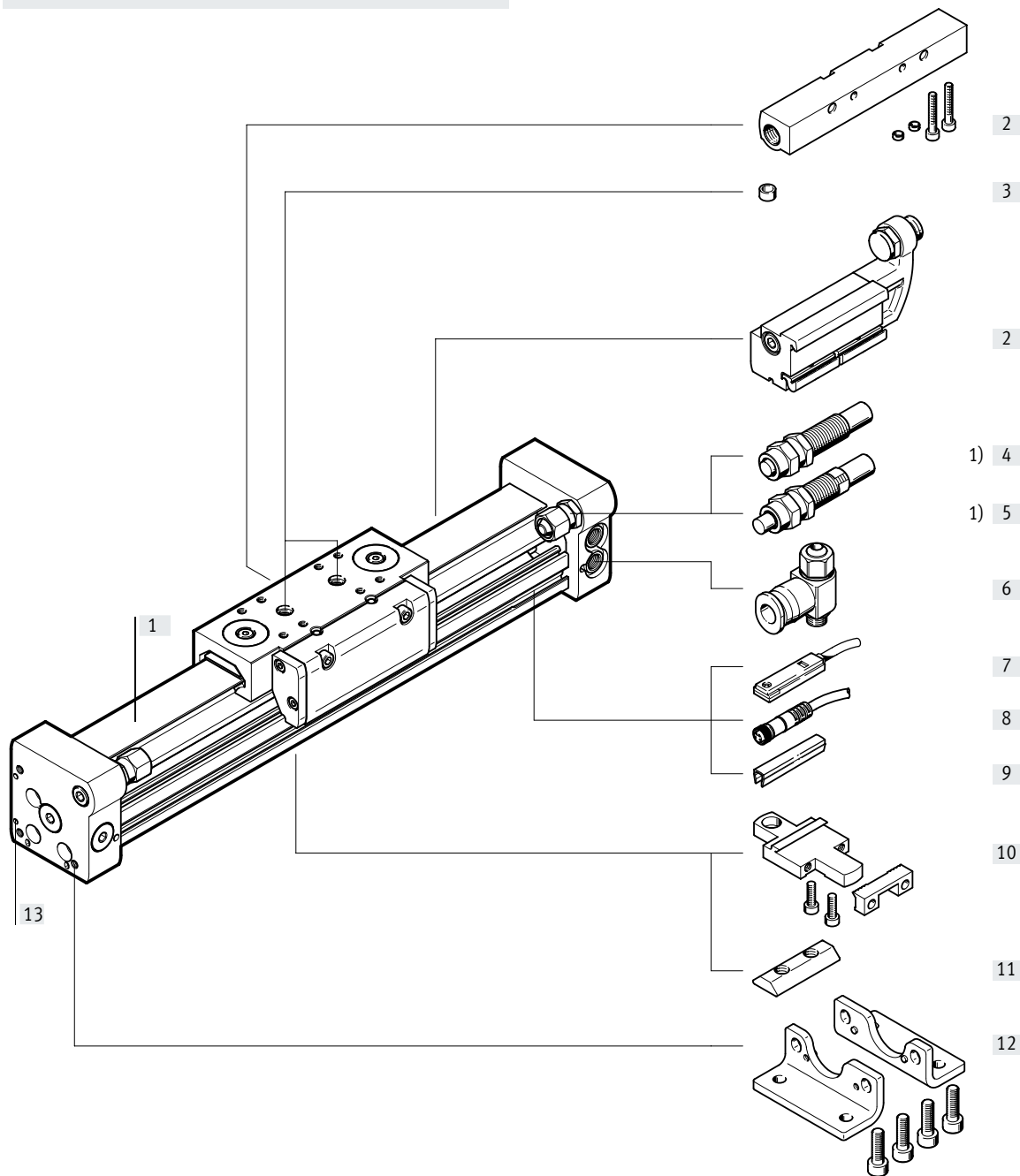

## Peripherals overview

Variants and accessories			
Type/order code	For piston diam.	Description	→ Page/Internet
[1] Linear drive DGC-GF	18 ... 63	Linear drive without accessories, plain-bearing guide	24
[2] Mechanical end-position limiter YWZ	18 ... 63	For variable end-position adjustment, e.g. for format adjustments	70
[3] Centring pin/sleeve <sup>1)</sup> ZBS/ZBH	18 ... 63	For centring loads and attachments on the slide	74
– Cushioning PPV	18 ... 63	Adjustable, pneumatic end-position cushioning. Used at medium speeds.	39
[4] Shock absorber YSR	18 ... 63	Self-adjusting, hydraulic shock absorber with spring return and linear cushioning characteristics.	39
[5] Shock absorber YSRW	18 ... 63	Self-adjusting, hydraulic shock absorber with spring return and progressive cushioning characteristics	39
[6] One-way flow control valve GRLA	18 ... 63	For regulating speed	75
[7] Proximity sensor G/H/I/J	18 ... 63	For sensing the slide position	75
[8] Connecting cable V	18 ... 63	For proximity sensor	76
[9] Slot cover L	18 ... 63	For protecting against contamination and securing the proximity sensor cable in place	74
[10] Profile mounting M	18 ... 63	Simple and precise mounting option via dovetail connection.	66
[11] Slot nut B	25 ... 63	For mounting attachments	74
[12] Foot mounting F	18 ... 63	For mounting on the end cap	64
[13] Centring sleeve ZBH	50, 63	For centring the drive without foot mountings (user-specific)	74

1) Included in the scope of delivery of the drive

## Data sheet

### Function

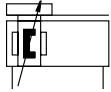

www.festo.com

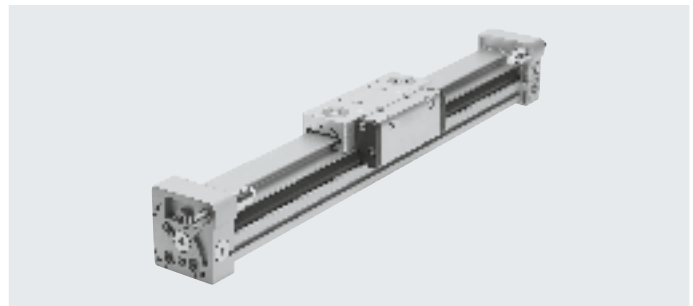

- Diameter  
18 ... 63 mm
- Stroke length  
1 ... 8500 mm

General technical data		18	25	32	40	50	63
Piston diameter		18	25	32	40	50	63
Design		Rodless drive					
Moment compensator principle		Slotted cylinder, mechanically coupled					
Guide		Plain-bearing guide					
Mode of operation		Double-acting					
Stroke	[mm]	1 ... 3000			1 ... 8500		1 ... 5000
Pneumatic connection		M5		G1/8		G1/4	G3/8
Cushioning → page 27							
DGC...-PPV		Adjustable at both ends					
DGC...-YSR...		Self-adjusting at both ends					
Cushioning length with cushioning PPV	[mm]	16.5	15.5	17.5	29.5	29.8	31.1
Max. speed	[m/s]	3					
Position sensing		Via proximity sensor					
Type of mounting		Profile mounting					
		Foot mounting					
		Direct mounting					
Mounting position		Any					

† Note: This product conforms to ISO 1179-1 and ISO 228-1.

Operating and environmental conditions		18	25	32	40	50	63	
Piston diameter		18	25	32	40	50	63	
Operating pressure	[bar]	2 ... 8			1.5 ... 8			
Operating medium		Compressed air to ISO 8573-1:2010 [7:-:-]						
Note on operating/pilot medium		Lubricated operation possible (in which case lubricated operation will always be required)						
Ambient temperature <sup>1)</sup>	[°C]	-10 ... +60						
Food-safe <sup>2)</sup>		→ supplementary information on materials						
Corrosion resistance class CRC <sup>3)</sup>		2						

1) Note operating range of proximity sensors

2) Additional information is available at [www.festo.com/sp](http://www.festo.com/sp) → Certificates.

3) Corrosion resistance class CRC 2 to Festo standard FN 940070

Moderate corrosion stress. Indoor applications in which condensation can occur. External visible parts with primarily decorative surface requirements which are in direct contact with a normal industrial environment.

Forces [N] and impact energy [J]		18	25	32	40	50	63
Piston diameter		18	25	32	40	50	63
Theoretical force at 6 bar		153	295	483	754	1178	1870
Impact energy at the end positions		→ page 27					

## Data sheet

<b>ATEX<sup>1)</sup></b>	
Explosion-proof ambient temperature [°C]	$-10^{\circ}\text{C} \leq T_a \leq +60^{\circ}\text{C}$
CE marking (see declaration of conformity)	To EU Explosion Protection Directive (ATEX)
<b>EX2 certification</b>	
ATEX category for gas	II 3G
Type of ignition protection for gas	Ex h IIC T4 Gc X
ATEX category for dust	II 3D
Type of ignition protection for dust	Ex h IIIC T120°C Dc X
<b>EX3 certification</b>	
ATEX category for gas	II 2G
Type of ignition protection for gas	Ex h IIC T4 Gb X

1) Note the ATEX certification of the accessories.

<b>Weight [g]</b>						
Piston diameter	18	25	32	40	50	63
Basic weight with 0 mm stroke	763	1609	2532	5252	10065	16308
Additional weight per 10 mm stroke	23	35	55	76	117	180
Moving mass	267	526	824	1725	3319	5226

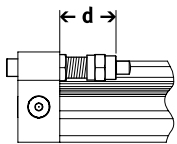
**Adjustable end-position range d [mm]**

 **Note**

The permissible kinetic energy decreases if the stroke is reduced with PPV adjustable cushioning at both ends.

Piston diameter	18	25	32	40	50	63
<b>Cushioning</b>						
DGC...-PPV	13.8 ... 15.8	21.1 ... 25.1	25.2 ... 30.2	28.7 ... 33.7	28.7 ... 33.7	38.8 ... 43.8
DGC...-YSR/YSRW	14.5 ... 24.5	22.5 ... 32.5	27.3 ... 37.3	31 ... 41	31 ... 56	41 ... 76

**Materials**

Sectional view

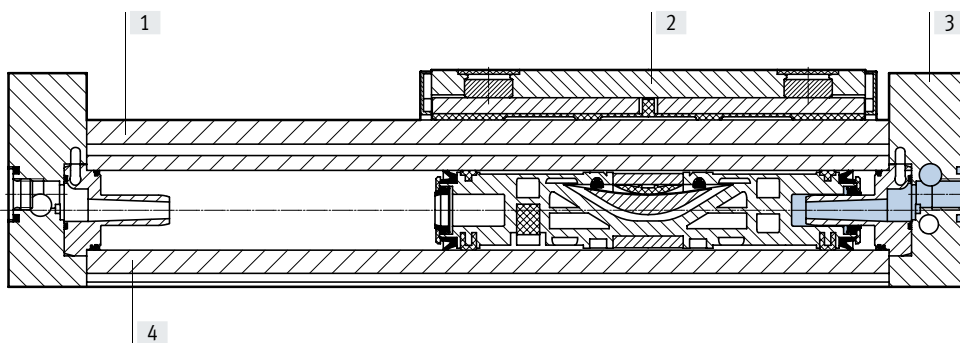

<b>Linear drives</b>		
[1]	Guide rail	Anodised aluminium
[2]	Slide	Anodised aluminium
[3]	End cap	Anodised aluminium
[4]	Cylinder barrel	Anodised aluminium
-	Piston seal	Polyurethane
	Sealing band/cover strip	Polyurethane
	Slide elements	Polyacetal
	Note on materials	RoHS-compliant

## Data sheet

### Characteristic load values

The indicated forces and torques refer to the centre of the slide surface. These values must not be exceeded during dynamic operation. Special attention must be paid to the deceleration phase.

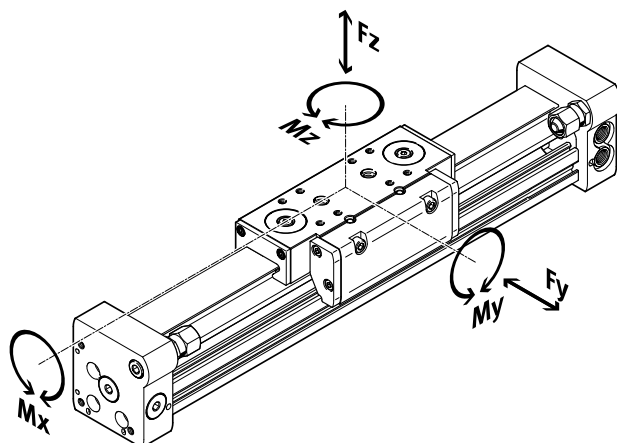

**Note**  
To prevent the drive with plain-bearing guide DGC-GF from self-locking when used vertically and with a high torque load, the variant with the recirculating ball bearing guide DGC-KF → page 40 is recommended.

If the drive is subjected to two or more of the indicated forces and torques simultaneously, the following equation must be satisfied in addition to the indicated maximum loads:

$$\frac{F_y}{F_{y_{max.}}} + \frac{F_z}{F_{z_{max.}}} + \frac{M_x}{M_{x_{max.}}} + \frac{M_y}{M_{y_{max.}}} + \frac{M_z}{M_{z_{max.}}} \leq 1$$

### Permissible forces and torques in relation to a travel speed of 0.2 m/s

Piston diameter		18	25	32	40	50	63
$F_{y_{max.}}$	[N]	440	640	900	1380	1500	2300
$F_{z_{max.}}$	[N]	540	1300	1800	2000	2870	4460
$M_{x_{max.}}$	[Nm]	3.4	8.5	15	28	54	96
$M_{y_{max.}}$	[Nm]	20	40	70	110	270	450
$M_{z_{max.}}$	[Nm]	8.5	20	33	54	103	187

### Influence of ferritic materials on proximity sensors

Ferritic materials (steel parts or sheet metal) in the immediate vicinity of the proximity sensors can cause sensing malfunctions. The following safety distances must be observed.

The distance depends on the position of the proximity sensor (see [1] and [2]).

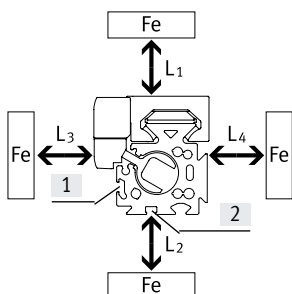

Piston diameter		8	12	18	25	32	40	50	63
Distance L1	[1] [mm]	0	0	0	0	0	0	0	0
	[2] [mm]	-	-	0	0	0	0	0	0
Distance L2	[1] [mm]	20	10	10	10	0	0	0	0
	[2] [mm]	-	-	25	25	25	25	25	25
Distance L3	[1] [mm]	30	25	25	25	25	25	25	25
	[2] [mm]	-	-	10	10	0	0	0	0
Distance L4	[1] [mm]	0	0	0	0	0	0	0	0
	[2] [mm]	-	-	0	0	0	0	0	0

## Data sheet

### Maximum permissible piston speed $v$ as a function of payload $m$ and distance $r_{\max}$ from the centre of mass

With cushioning PPV

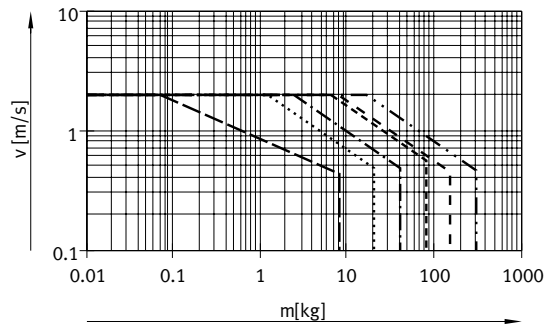

With cushioning YSR

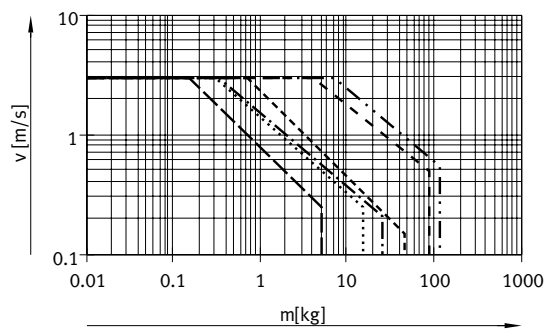

With cushioning YSRW

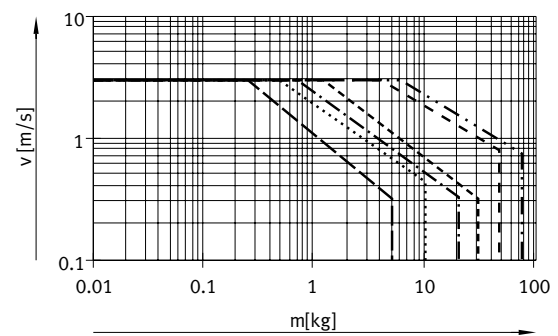

- ∅ 18
- ..... ∅ 25
- · - · ∅ 32
- ∅ 40
- ∅ 50
- · - · ∅ 63

**Note**

These specifications represent the maximum values that can be achieved. In practice, these values can fluctuate dependent on the position of the payload and mounting position.

### Operating range of the cushioning

The end-position cushioning must be adjusted to ensure jerk-free operation. If the operating conditions are outside the permissible range, the moving mass must be cushioned using suitable equipment (external shock absorbers), preferably at the centre of mass.

**Note**

To avoid distortion in the slide, the bearing surfaces of the attachments must maintain a flatness of at least 0.03 mm.

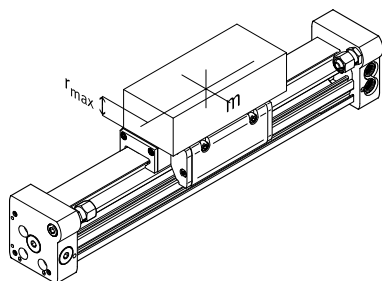

Data for horizontal mounting position:

Piston diameter	8	12	18	25	32	40	50	63
Distance $r_{\max}$ [mm]	25	35	35	50	50	50	50	50

## Data sheet

### Number of profile mountings MUC as a function of weight force F and distance l between supports

In order to limit deflection in the case of large strokes, the drive may need to be supported. The following graphs are provided to determine the maximum permissible distance between supports as a function of the mounting position and the applied weight and normal forces.

#### Horizontal mounting position

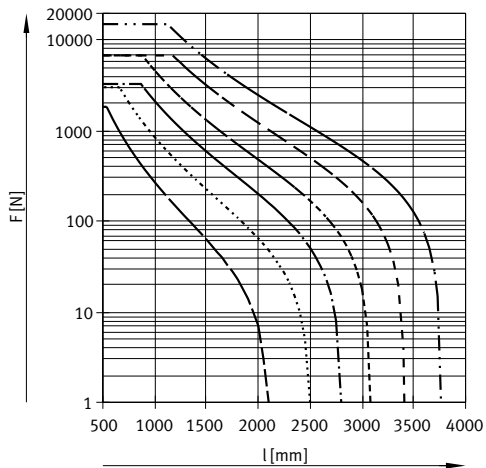
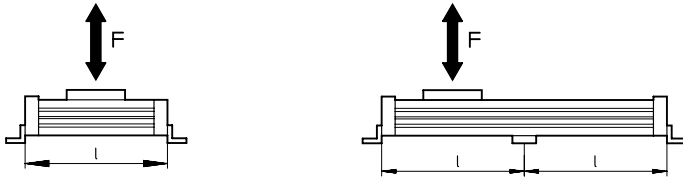

## Data sheet

### Number of profile mountings MUC as a function of weight force F and distance l between supports

In order to limit deflection in the case of large strokes, the drive may need to be supported. The following graphs are provided to determine the maximum permissible distance between supports as a function of the mounting position and the applied weight and normal forces.

#### Vertical mounting position

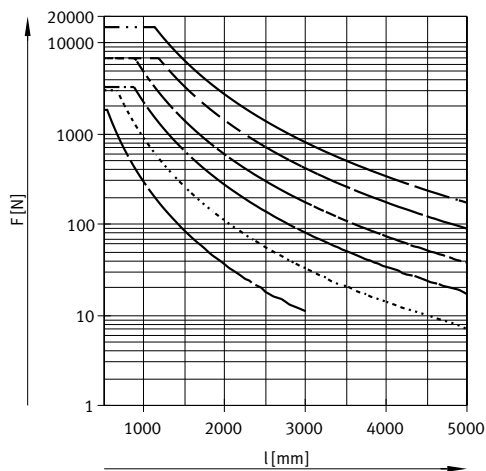
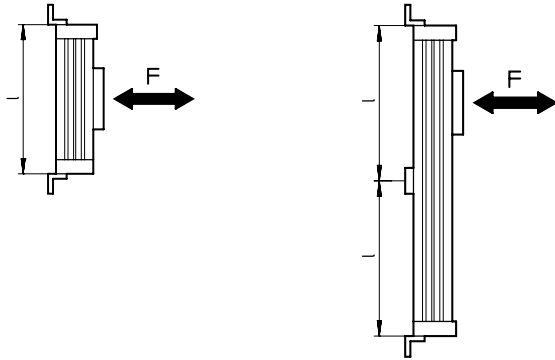

#### Example:

The drive DGC-25-1500 is subjected to a force of 300 N in a horizontal mounting position.

The drive has an overall length of:  
 $l = \text{stroke length} + L1$   
 (see dimensions)  
 $= 1500 \text{ mm} + 200 \text{ mm}$   
 $= 1700 \text{ mm}$

According to the graph, the max. distance between supports for the drive DGC-25 with a force of 300 N is 1300 mm.

In this example, profile mountings are required as the max. distance between supports (1300 mm) is smaller than the overall length of the drive (1700 mm).

Data sheet

Dimensions

Download CAD data → [www.festo.com](http://www.festo.com)

∅ 18 ... 40

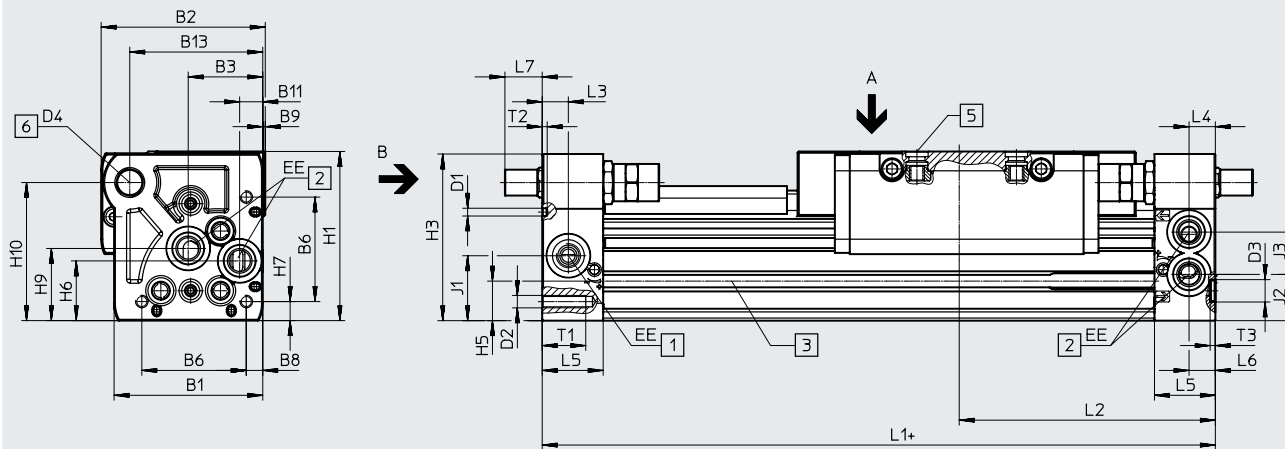

View B

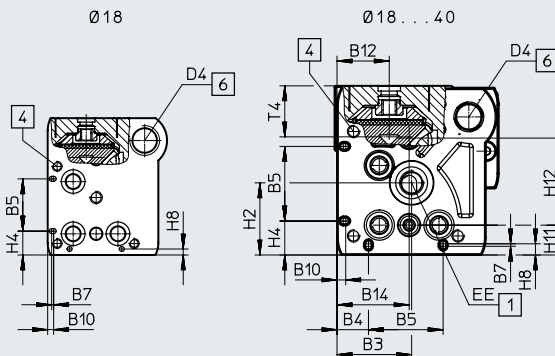

+ plus stroke length

- [1] Compressed air supply port options on 2 sides
- [2] Compressed air supply port options on 2 sides, for compressed air supply port at one end
- [3] Sensor slot for proximity sensor
- [4] Mounting hole for foot mounting HPC
- [5] Drilled hole for centring pin/sleeve
- [6] Thread for end stop

- Note

The linear drive is actuated at the right end or at both ends by default. The linear drive can be actuated at the left end or at both ends by specifying the order code DL in the modular product system.

## Data sheet

∅	B1	B2	B3	B4	B5	B6	B7	B8	B9	B10	B11	B12
[mm]					±0.05							
18	44.5	49.9	19.5	8.8	21	31	0.8	3.8	1	2.4	5.5	15.5
25	59.8	66	30	12.65	30	42	1	6.65	1	3.5	9.3	21
32	73	79	38.5	5.7	63.1	57.5	–	8.5	1.5	14	14.9	18
40	91	98.5	45	17.2	55	65	–	12.2	2	8	16.5	24.8

∅	B13	B14	D1 ∅	D2	D3 ∅	D4	EE	H1	H2	H3	H4	H5
[mm]			±0.05		H7						±0.2	
18	39	19.5	2	M4	5	M12x1	M5	56.3	23.1	55	9.6	13.4
25	53.5	30	3	M5	9	M12x1	G1/8	68	29	67	13.65	15.8
32	66.5	38.5	3	M6	9	M14x1	G1/8	78.5	30	77	5.7	17
40	80.5	45	4	M6	9	M16x1	G1/4	99.5	41.5	97.5	17.2	25

∅	H6	H7	H8	H9	H10	H11	H12	J1	J2	J3	L1	L2	L3
[mm]						±0.15	±0.05						
18	20	4.6	2.4	25.2	46	8.5	30	20	16.5	11	150	74.5	5.7
25	24	7.65	4.5	29	55.5	12	35	26.1	18.6	17	200	100	10.5
32	27.7	8.5	14	35.2	63.8	11.45	50	30	22	18.5	250	124.8	14.5
40	36.5	12.2	8	44	81.5	15	60	35	26	26	300	150	14.6

∅	L4	L5	L6	L7			T1	T2	T3	T4	Stroke tolerance
				PPV	YSR	YSRW					
[mm]										+0.2	
18	5.8	15	5.5	0	15.9	19.4	9	2	3.1	17.1	0 ... 2.5
25	10.6	24.5	10.6	0	12.5	15	17.5	2	2.1	20.5	
32	14.5	30.5	14.5	0	8.5	15.5	15	2	2.1	21.3	
40	14.6	33.5	14.6	0	12.8	21	20	3	2.1	30.7	

 **Note**

This product conforms to ISO 1179-1 and ISO 228-1.

Length tolerance		≤ 1000	≤ 2000	≤ 3000	≤ 4000	≤ 5000	≤ 6000	≤ 7000	≤ 8000	≤ 9000
For stroke	[mm]									
L1	[mm]	+0.90	+1.10	+1.40	+1.50	+1.60	+1.70	+2.20	+2.30	+2.40



Data sheet

∅ [mm]	B1	B2	B3	B6	B8	B9	B11	B12	B13	B14 ±0.05	B15	D2	D3 ∅ H7	D4
50	113	126.5	60	81.6	12	–	21	24	97	52.8	8	M8	9	M22x1.5
63	142	149	68	97	19.5	5	21	30	123.5	68	15.5	M10	9	M26x1.5

∅ [mm]	EE	H1	H2	H3	H5	H6	H7	H9	H10	H11 ±0.2	H12 ±0.05	H13	J1	J2
50	G1/4	124.5	38.5	122.5	29.3	36	12	53	104.5	8	100	52.8	30.5	30.5
63	G3/8	153.5	48.5	151	34.8	46	19.5	67	131	15.5	120	68	41.5	39.5

∅ [mm]	J3	L1	L2	L3	L4	L5	L6	L7			T1	T3 +0.2	T4	Stroke tolerance
								PPV	YSR	YSRW				
50	28	350	175	17	17	41	17	0	31	36.3	24	2.1	30.4	0 ... 2.5
63	31.5	400	200	20	20	44	20	0	38.3	48.3	27.5	2.1	36.2	



**Note**

This product conforms to ISO 1179-1 and ISO 228-1.

Length tolerance		≤ 1000		≤ 2000		≤ 3000		≤ 4000		≤ 5000	
For stroke	[mm]										
L1	[mm]	+0.90		+1.10		+1.40		+1.50		+1.60	

Data sheet

Dimensions

Download CAD data → [www.festo.com](http://www.festo.com)

Slide

∅ 18

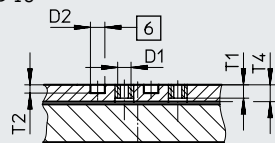

∅ 25

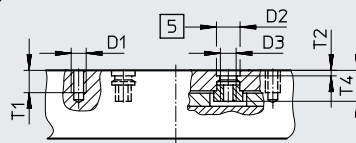

View A

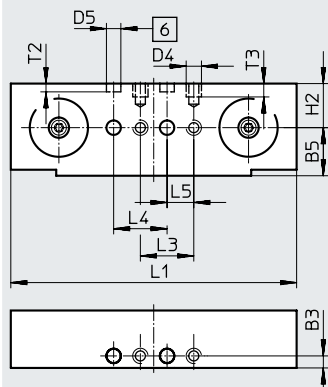

View A

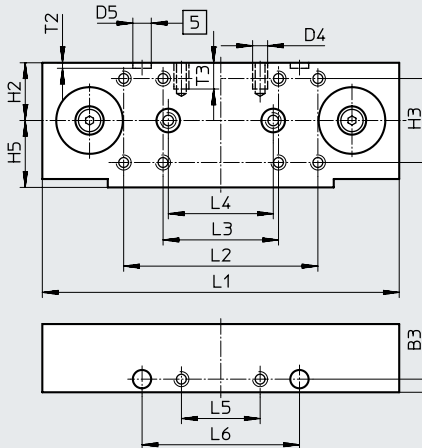

- [5] Drilled hole for centring sleeve ZBH
- [6] Drilled hole for centring pin ZBS

∅	B3	D1	D2 ∅ H7	D3	D4	D5 ∅ H7	H2	H3	H4	H5	L1
[mm]	±0.05								±0.03	±0.1	±0.1
18	4.5	M5	5	-	M5	5	16.5	-	-	18	107
25	5	M5	9	M6	M5	7	22	32±0.2	-	25.5	136

∅	L2	L3	L4	L5	L6	L7	T1	T2	T3	T4
[mm]	±0.1		±0.03	±0.1	±0.05	±0.1				
18	-	20±0.1	20	10	-	-	5	3.1±0.1	5	6.3
25	74	44±0.2	40	30	60	-	8.5	2.1±0.2	10	11.8

Data sheet

Dimensions

Download CAD data → [www.festo.com](http://www.festo.com)

Slide

∅ 32

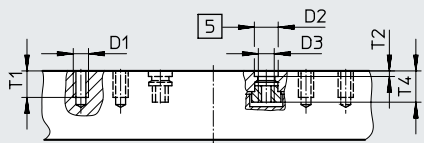

∅ 40

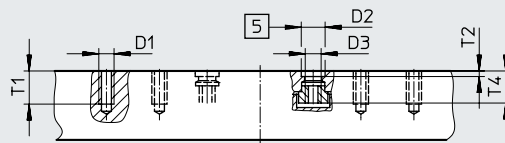

View A

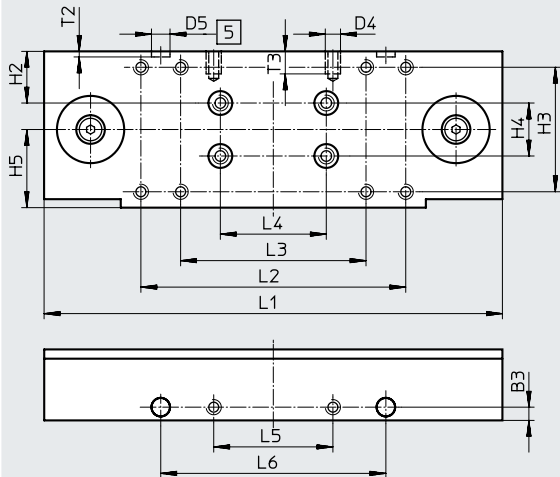

View A

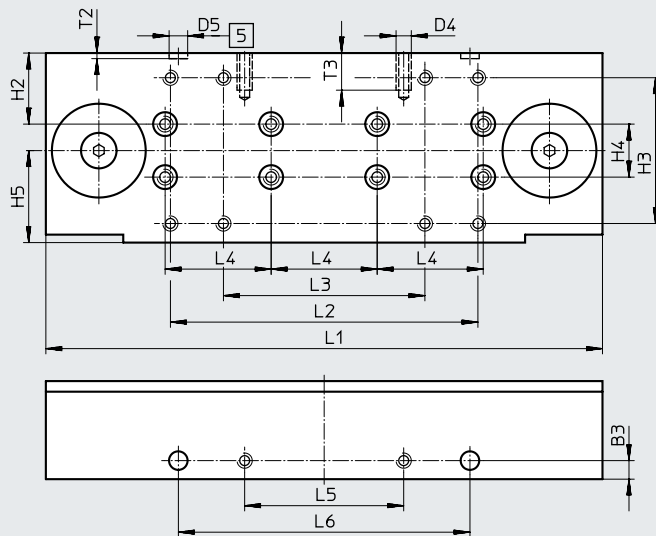

[5] Drilled hole for centring sleeve ZBH

∅	B3	D1	D2 ∅ H7	D3	D4	D5 ∅ H7	H2	H3	H4	H5	L1
32	±0.05	M5	9	M6	M5	7	19.5	47±0.2	±0.03	±0.1	±0.1
40	7	M5	9	M6	M6	7	26.8	55±0.2	20	34.7	210

∅	L2	L3	L4	L5	L6	L7	T1	T2	T3	T4
[mm]	±0.1		±0.03	±0.1	±0.05	±0.1				
32	100	70±0.2	40	45	85	–	10	2.1±0.2	8.5	11.8
40	116	76±0.2	40	60	110	–	12.5	2.1±0.2	14	12.1

Data sheet

Dimensions

Download CAD data → [www.festo.com](http://www.festo.com)

Slide

∅ 50

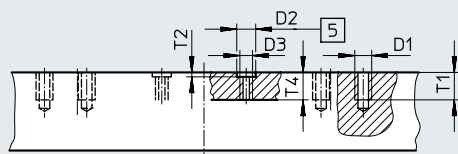

∅ 63

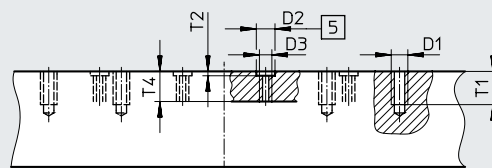

View A

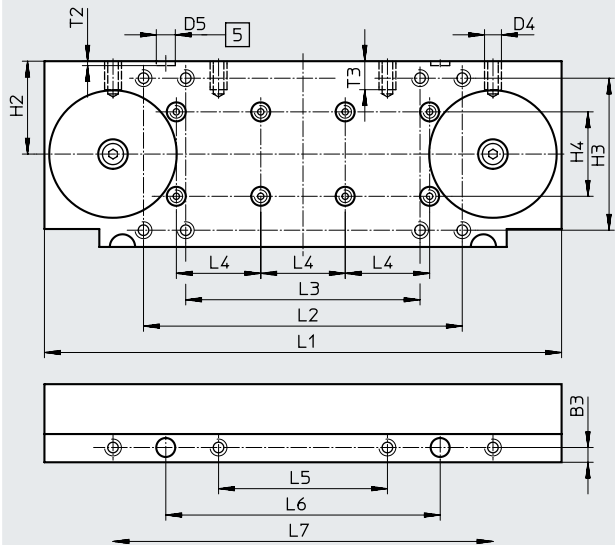

View A

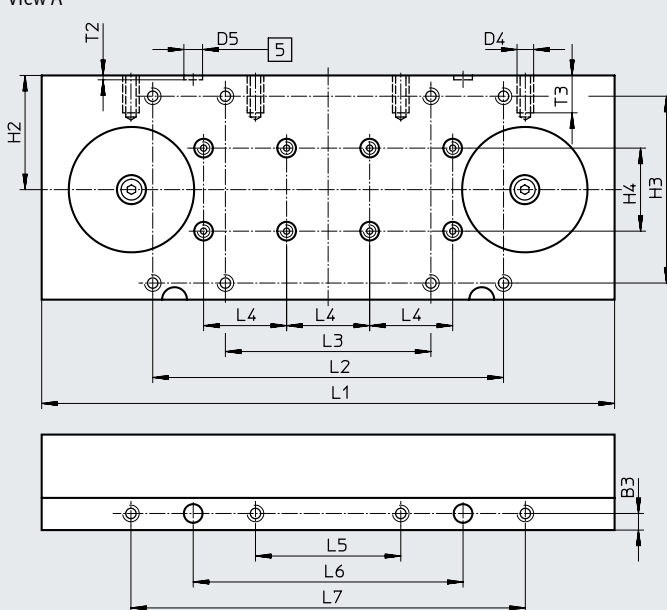

[5] Drilled hole for centring sleeve ZBH

∅	B3	D1	D2 ∅ H7	D3	D4	D5 ∅ H7	H2	H3	H4	H5	L1
[mm]	±0.05								±0.03	±0.1	±0.1
50	7	M8	9	M6	M8	9	44	72±0.3	40	-	245
63	8	M8	9	M6	M8	9	55	90±0.3	40	-	276

∅	L2	L3	L4	L5	L6	L7	T1	T2	T3	T4
[mm]	±0.1		±0.03	±0.1	±0.05	±0.1				
50	151	111±0.2	40	80	130	180	13	2.1±0.2	13.5	13
63	169	99±0.2	40	70	130	190	16	2.1±0.2	18	14.5

Data sheet

Dimensions

Download CAD data → [www.festo.com](http://www.festo.com)

Profile barrel

∅ 18

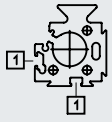

∅ 25

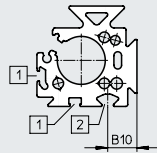

∅ 32

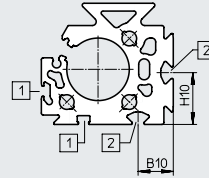

∅ 40

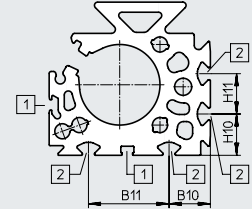

∅ 50

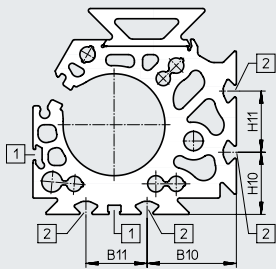

∅ 63

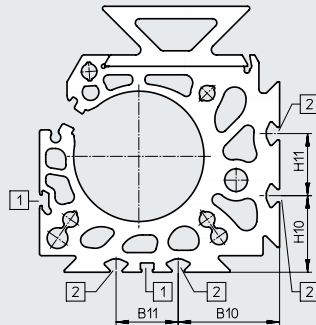

- [1] Sensor slot for proximity sensor
- [2] Mounting slot for slot nut

∅	B10	B11	H10	H11
[mm]				
25	15.23	-	-	-
32	18	-	26.5	-
40	20.5	40	20.5	20
50	43.8	30	30.5	30
63	49	30	37	30

## Ordering data – Modular product system

### Order code

 - Note

1) Operation without cushioning components is not permitted.

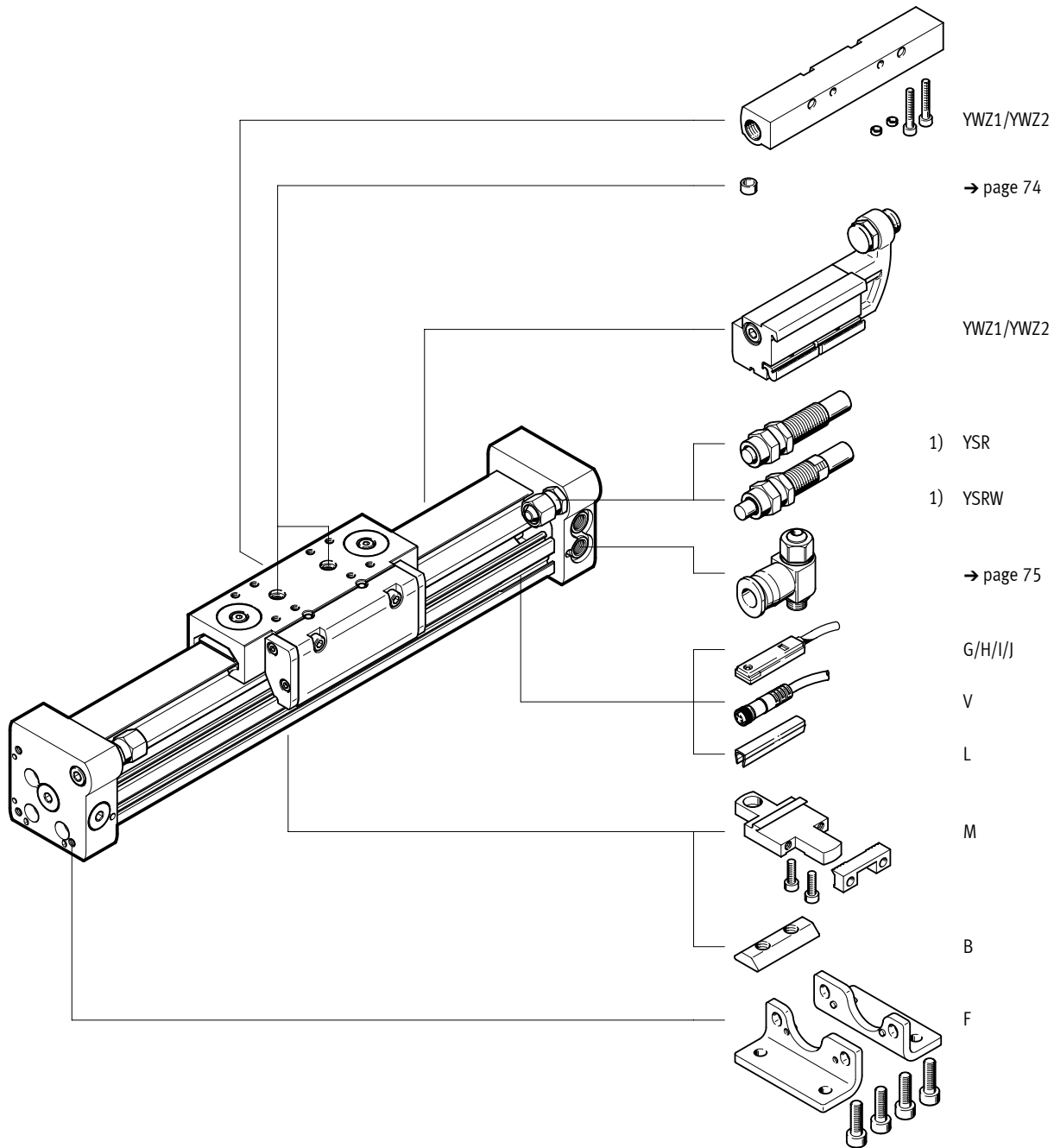

## Ordering data – Modular product system

Ordering table									
Size	18	25	32	40	50	63	Condi- tions	Code	Enter code
Module no.	<b>532446</b>	<b>532447</b>	<b>532448</b>	<b>532449</b>	<b>532450</b>	<b>532451</b>			
Function	Linear drive							DGC	DGC
Piston diameter [mm]	18	25	32	40	50	63		★ -...	
Stroke [mm]	1 ... 3000	1 ... 8500		1 ... 5000				★ -...	
Guide	Plain-bearing guide							★ -GF	-GF
Cushioning	Pneumatic cushioning, adjustable at both ends							★ -PPV	
	Shock absorber, self-adjusting							-YSR	
	Shock absorber, self-adjusting, progressive							★ -YSRW	
Position sensing	Via proximity sensor							★ -A	-A
Compressed air supply port	At the right end or at both ends							★	
	At the left end or at both ends							-DL	
Lubrication	Standard							★	
	Lubrication approved for use in food applications						[1]	-H1	
EU certification	Without							★	
	II 3GD						[2]	-EX2	
	II 2G						[2]	-EX3	
Accessories	Enclosed separately (can be retrofitted)							ZUB-	ZUB-
Foot mounting	1							F	
Profile mounting	1 ... 9							...M	
Slot nut for mounting slot	-	1 ... 9					...B		
Proximity sensor	2.5 m cable	1 ... 9					...G		
	Plug M8	1 ... 9					...H		
Proximity sensor, contactless, PNP	2.5 m cable	1 ... 9					...I		
	Plug M8	1 ... 9					...J		
Connecting cable	M8, 2.5 m	1 ... 9					...V		
Slot cover for sensor slot	1 ... 9							...L	
Mechanical end-position limiter	Without								
	Variable end position, at one end						[3]	YWZ1	
	Variable end position, at both ends						[3]	YWZ2	
Operating instructions	Express waiver – no operating instructions to be included (already available)							-O	

- [1] H1 Not with cushioning YSR, YSRW  
 [2] EX2, EX3 Not with proximity sensor G, H, I, J, connecting cable V  
 [3] YWZ1, YWZ2 Only with cushioning YSR or YSRW

Festo core product range



Generally ready for dispatch from the factory within 24 hours  
 Generally ready for dispatch from the factory within 5 days

Peripherals overview

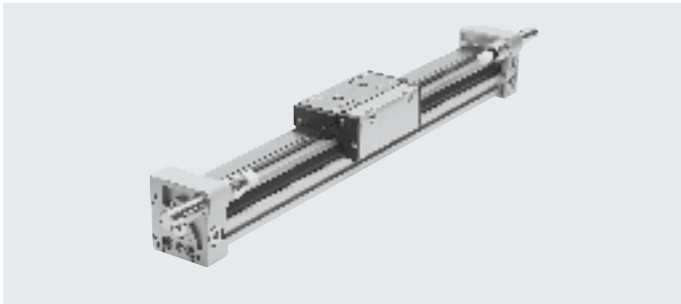

 **Note**

1) Operation without cushioning components is not permitted.

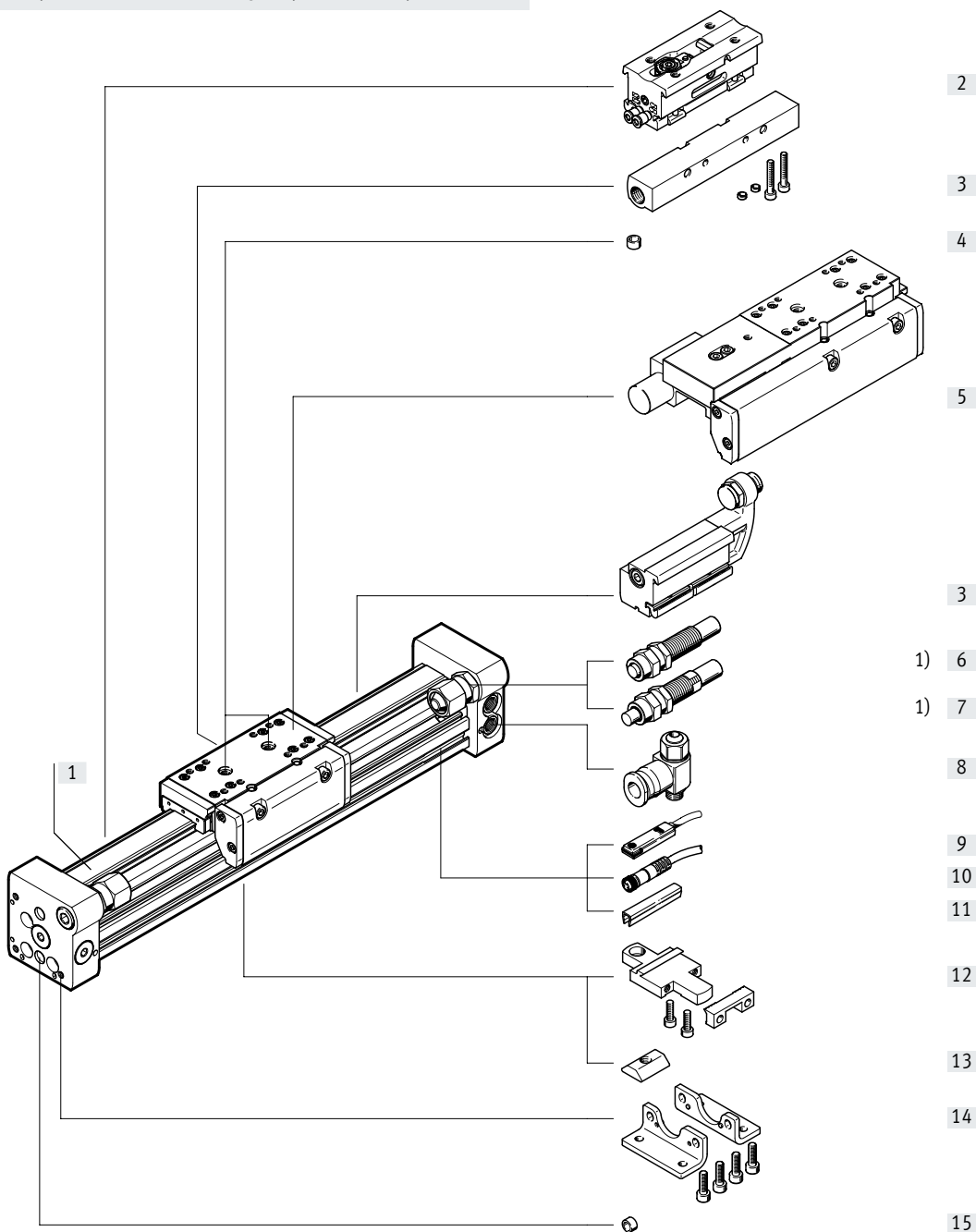

## Peripherals overview

Variants and accessories			
Type/order code	For piston diam.	Description	→ Page/Internet
[1] Linear drive DGC-KF	8 ... 63	Linear drive without accessories, with recirculating ball bearing guide	42
[2] Intermediate-position module Z1/Z2/Z3	25, 32, 40	Enables up to three intermediate positions	72
[3] Mechanical end-position limiter YWZ	18 ... 63	For variable end-position adjustment, e.g. for format adjustments	70
[4] Centring pin/sleeve <sup>1)</sup> ZBS/ZBH	8 ... 63	For centring loads and attachments on the slide	74
[5] Clamping unit 1H-PN	25, 32, 40, 50	For holding loads	45
– Cushioning P	8, 12	Non-adjustable, elastic cushioning. Used only at low speeds.	62
– Cushioning PPV	18 ... 63	Adjustable, pneumatic end-position cushioning. Used at medium speeds.	62
[6] Shock absorber YSR	8 ... 63	Self-adjusting, hydraulic shock absorber with spring return and linear cushioning characteristics.	62
[7] Shock absorber YSRW	8 ... 63	Self-adjusting, hydraulic shock absorber with spring return and progressive cushioning characteristics	62
[8] One-way flow control valve GRLA	8 ... 63	For regulating speed	75
[9] Proximity sensor G/H/I/J	8 ... 63	For sensing the slide position	75
[10] Connecting cable V	8 ... 63	For proximity sensor	76
[11] Slot cover L	18 ... 63	For protecting against contamination and securing the proximity sensor cable in place	74
[12] Profile mounting M	8 ... 63	Simple and precise mounting option via dovetail connection.	66
[13] Slot nut B	25 ... 63	For mounting attachments	74
[14] Foot mounting F	8 ... 63	For mounting on the end cap	64
[15] Centring pin/sleeve ZBS/ZBH	8 ... 63	For centring the drive without foot mountings (user-specific)	74

1) Included in the scope of delivery of the drive

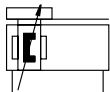

## Data sheet

### Function

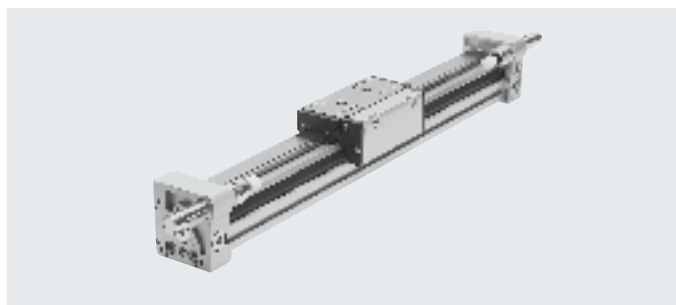

www.festo.com



-  Diameter  
8 ... 63 mm
-  Stroke length  
1 ... 8500 mm

General technical data		8	12	18	25	32	40	50	63
Piston diameter		8	12	18	25	32	40	50	63
Design		Rodless drive							
Moment compensator principle		Slotted cylinder, mechanically coupled							
Guide		External recirculating ball bearing guide							
Mode of operation		Double-acting							
Stroke [mm]		1 ... 1300	1 ... 1900	1 ... 3000	1 ... 8500			1 ... 5000	
Pneumatic connection		M5			G1/8		G1/4		G3/8
Cushioning → page 46									
DGC...-P		Non-adjustable at both ends		–					
DGC...-PPV		–		Adjustable at both ends					
DGC...-YSR...		Self-adjusting at both ends							
Cushioning length with cushioning PPV [mm]		–		16.5	15.5	17.5	29.5	29.8	31.1
Max. speed [m/s]		1	1.2	3					
Repetition accuracy [mm]		0.02 (with shock absorber YSR/YSRW)							
Position sensing		Via proximity sensor							
Type of mounting		Profile mounting Foot mounting Direct mounting							
Mounting position		Any							

### Note

This product conforms to ISO 1179-1 and ISO 228-1.

Operating and environmental conditions		8	12	18	25	32	40	50	63
Piston diameter		8	12	18	25	32	40	50	63
Operating pressure [bar]		2.5 ... 8			2 ... 8		1.5 ... 8		
Operating medium		Compressed air to ISO 8573-1:2010 [7:--:--]							
Note on operating/pilot medium		Lubricated operation possible (in which case lubricated operation will always be required)							
Ambient temperature <sup>1)</sup> [°C]		–10 ... +60							
Food-safe <sup>2)</sup>		–			→ supplementary information on materials				
Corrosion resistance class CRC <sup>3)</sup>		1							

1) Note operating range of proximity sensors

2) Additional information is available at [www.festo.com/sp](http://www.festo.com/sp) → Certificates.

3) Corrosion resistance class CRC 1 to Festo standard FN 940070

Low corrosion stress. Dry indoor application or transport and storage protection. Also applies to parts behind coverings, in the non-visible interior area, and parts which are covered in the application (e.g. drive trunnions).

## Data sheet

Forces [N]								
Piston diameter	8	12	18	25	32	40	50	63
Theoretical force at 6 bar	30	68	153	295	483	754	1178	1870
Impact energy at the end positions	→ page 46							

ATEX <sup>1)</sup>	
Explosion-proof ambient temperature [°C]	-10°C ≤ Ta ≤ +60°C
CE marking (see declaration of conformity)	To EU Explosion Protection Directive (ATEX)
EX2 certification	
ATEX category for gas	II 3G
Type of ignition protection for gas	Ex h IIC T4 Gc X
ATEX category for dust	II 3D
Type of ignition protection for dust	Ex h IIIC T120°C Dc X
EX3 certification	
ATEX category for gas	II 2G
Type of ignition protection for gas	Ex h IIC T4 Gb X

1) Note the ATEX certification of the accessories.

Weight [g]								
Piston diameter	8	12	18	25	32	40	50	63
DGC...								
Basic weight with 0 mm stroke	225	391	975	2113	2837	6996	13342	22220
Additional weight per 10 mm stroke	11	16	31	49	74	117	153	236
Moving mass	77	149	331	732	1146	2330	4511	8225
DGC...-1H-PN – With clamping unit								
Basic weight with 0 mm stroke	–	–	–	3134	4272	12009	19394	–
Additional weight per 10 mm stroke	–	–	–	49	74	117	153	–
Moving mass	–	–	–	1405	2059	5494	8411	–

## Adjustable end-position range d [mm]

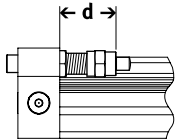

 **Note**

The permissible kinetic energy decreases if the stroke is reduced with PPV adjustable cushioning at both ends.

Piston diameter	8	12	18	25	32	40	50	63
Cushioning								
DGC...-P/PPV	11.3 ... 16.3	12.7 ... 17.7	13.8 ... 15.8	21.1 ... 25.1	25.2 ... 30.2	28.7 ... 33.7	28.7 ... 33.7	38.8 ... 43.8
DGC...-P/PPV-GP	–	–	16.9 ... 18.9	23.6 ... 27.6	25.2 ... 30.2	34.7 ... 39.7	–	–
DGC...-YSR/YSRW	12.8 ... 22.8	14 ... 24	14.5 ... 34.5	22.5 ... 47.5	27.3 ... 52.3	31 ... 56	31 ... 56	41 ... 76

## Data sheet

### Materials

Sectional view

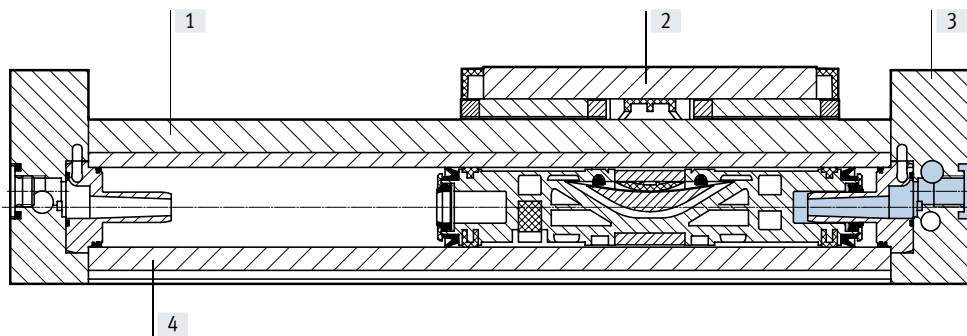

Linear drives

[1]	Guide rail	High-alloy steel
[2]	Slide	High-alloy steel
[3]	End cap	Anodised aluminium
[4]	Cylinder barrel	Anodised aluminium
-	Piston seal	Polyurethane
-	Sealing band/cover strip	Polyurethane
Note on materials		RoHS-compliant, free of copper and PTFE

### Influence of ferritic materials on proximity sensors

Ferritic materials (steel parts or sheet metal) in the immediate vicinity of the proximity sensors can cause sensing malfunctions. The following safety distances must be observed.

The distance depends on the position of the proximity sensor (see [1] and [2]).

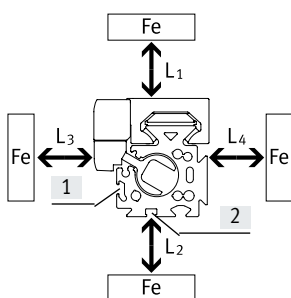

Piston diameter		8	12	18	25	32	40	50	63
Distance L1	[1] [mm]	0	0	0	0	0	0	0	0
	[2] [mm]	-	-	0	0	0	0	0	0
Distance L2	[1] [mm]	20	10	10	10	0	0	0	0
	[2] [mm]	-	-	25	25	25	25	25	25
Distance L3	[1] [mm]	30	25	25	25	25	25	25	25
	[2] [mm]	-	-	10	10	0	0	0	0
Distance L4	[1] [mm]	0	0	0	0	0	0	0	0
	[2] [mm]	-	-	0	0	0	0	0	0

## Data sheet

### Characteristic load values

The indicated forces and torques refer to the centre of the slide surface.

These values must not be exceeded during dynamic operation. Special attention must be paid to the deceleration phase.

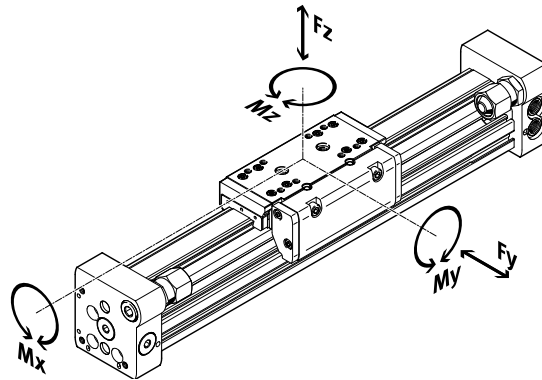

If the drive is subjected to two or more of the indicated forces and torques simultaneously, the following equation must be satisfied in addition to the indicated maximum loads:

$$\frac{F_y}{F_{y_{max.}}} + \frac{F_z}{F_{z_{max.}}} + \frac{M_x}{M_{x_{max.}}} + \frac{M_y}{M_{y_{max.}}} + \frac{M_z}{M_{z_{max.}}} \leq 1$$

Permissible forces and torques		8	12	18	25	32	40	50	63
Piston diameter									
$F_{y_{max.}}$	[N]	300	650	1850	3050	3310	6890	6890	15200
$F_{z_{max.}}$	[N]	300	650	1850	3050	3310	6890	6890	15200
$M_{x_{max.}}$	[Nm]	1.7	3.5	16	36	54	144	144	529
$M_{y_{max.}}$	[Nm]	4.5	10	51	97	150	380	634	1157
$M_{z_{max.}}$	[Nm]	4.5	10	51	97	150	380	634	1157

Technical data – Clamping unit		Dimensions → page 58			
Size		25	32	40	50
Pneumatic connection		M5	M5	M5	M5
Clamping type		Clamping via spring force, compressed air to release			
Static holding force	[N]	320	500	1200	1200
Max. number of emergency braking operations <sup>1)</sup> at reference energy	[J]	–	–	750 35	750 35
Number of clamping operations under rated load	[millions of switching cycles]	0.45	0.55	0.05	0.05

1) Emergency braking refers to braking the payload if the drive axis loses power.

Operating and environmental conditions – Clamping unit		
Operating medium		Compressed air to ISO 8573-1:2010 [7:4:4]
Operating pressure		
Clamping unit open	[bar]	4.5 ... 8
Clamping unit closed	[bar]	Unpressurised
Ambient temperature	[°C]	–10 ... +60

## Data sheet

### Maximum permissible piston speed $v$ as a function of payload $m$ and distance $r_{max}$ from the centre of mass

Piston diameter 8/12 with cushioning P

Piston diameter 18 ... 63 with cushioning PPV

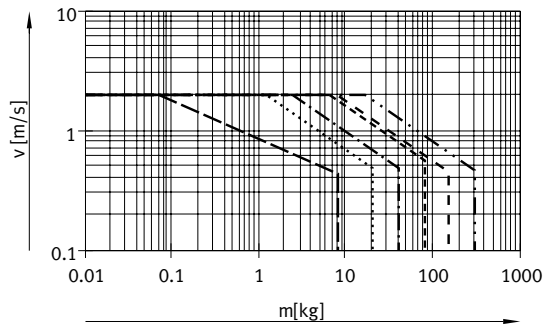
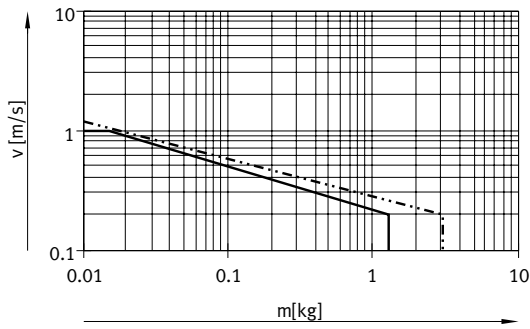

Piston diameter 8 ... 63 with cushioning YSR

Piston diameter 8 ... 63 with cushioning YSRW

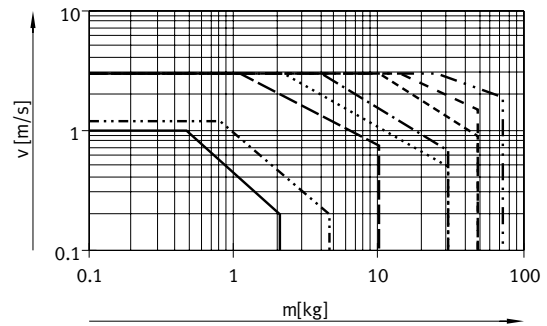
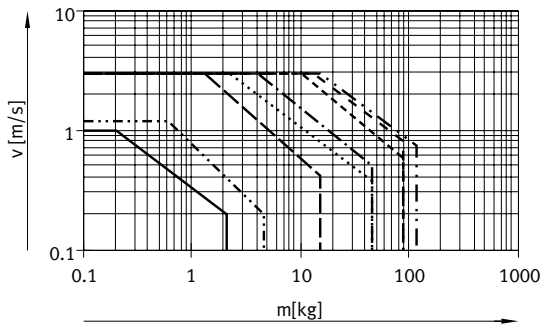

#### Note

These specifications represent the maximum values that can be achieved. In practice, these values can fluctuate dependent on the position of the payload and mounting position.

### Operating range of the cushioning

The end-position cushioning must be adjusted to ensure jerk-free operation. If the operating conditions are outside the permissible range, the moving mass must be cushioned using suitable equipment (shock absorbers, stops, etc.), preferably at the centre of mass.

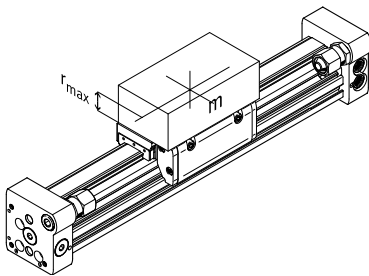

#### Note

To avoid distortion in the slide, the bearing surfaces of the attachments must maintain a flatness of at least 0.01 mm.

Data for horizontal mounting position:

Piston diameter	8	12	18	25	32	40	50	63
Distance $r_{max}$ [mm]	25	35	35	50	50	50	50	50

## Data sheet

### Number of profile mountings MUC as a function of weight force F and distance l between supports

In order to limit deflection in the case of large strokes, the drive may need to be supported. The following graphs are provided to determine the maximum permissible distance between supports as a function of the mounting position and the applied weight and normal forces.

#### Horizontal mounting position

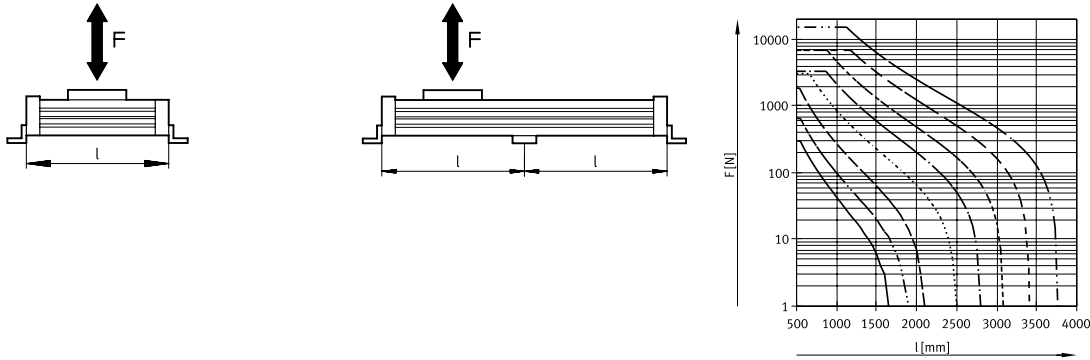

#### Vertical mounting position

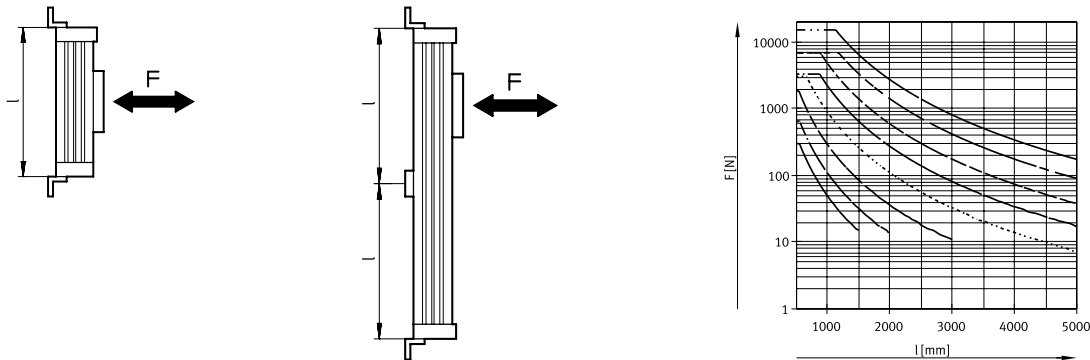

#### Example:

The drive DGC-25-1500 is subjected to a force of 300 N in a horizontal mounting position.

The drive has an overall length of:  
 $l = \text{stroke length} + L1$   
 (see dimensions)  
 $= 1500 \text{ mm} + 200 \text{ mm}$   
 $= 1700 \text{ mm}$

According to the graph, the max. distance between supports for the drive DGC-25 with a force of 300 N is 1300 mm.

In this example, profile mountings are required as the max. distance between supports (1300 mm) is smaller than the overall length of the drive (1700 mm).

## Data sheet

### Central lubrication

The lubrication adapters enable the guide of the linear drive DGC-KF to be permanently lubricated in applications in humid or wet ambient conditions using semi or fully automatic relubrication devices.

- For piston diameters 25, 32, 40, 63
- The modules are suitable for oils and greases.
- The dimensions of the linear drive DGC-KF are the same with and without central lubrication modules.
- Both lubrication adapters must be connected
- There are three connection options on each side
- Can be used in combination with:
  - Standard slide GK
  - Additional slide KL, KR
- Cannot be used in combination with:
  - Protected recirculating ball bearing guide GP

Slide dimensions

→ page 56

Order code C in the modular product system → page 63

### Connection options

Only the connection at the rear or on the top can be used in combination with shock absorbers in the end caps.

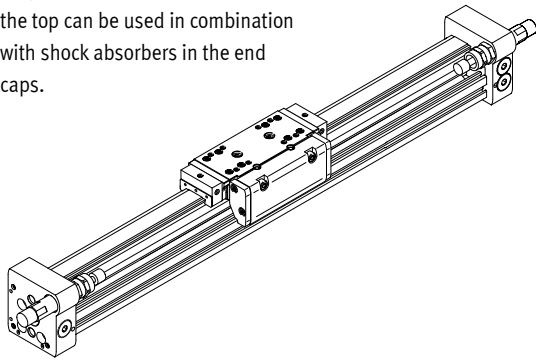

Only the connection on the front or top can be used in combination with shock absorber retainer DADP.

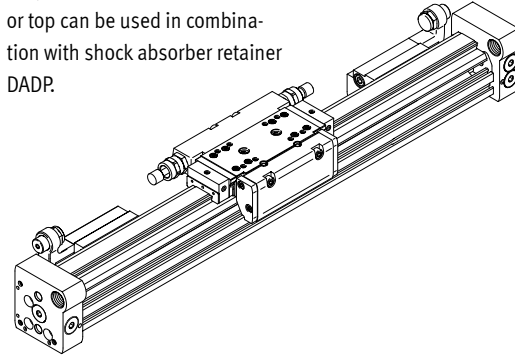

### Connection option for customer design

The drawing on the right shows the connection option on the top lubrication interface using a customer design.

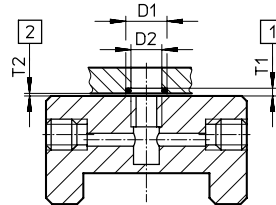

- D1 8<sup>+0.2</sup> mm
- D2 6 mm
- T1 0.6<sub>-0.05</sub> mm
- T2 0.1<sup>+0.2</sup> mm
- O-ring diameter 6x1 mm (DIN 3771)

[1] Slot depth for O-ring

[2] Required air gap

Additional dimensions → page 56

### Structure of a central lubrication system

A central lubrication system requires various additional components. The illustration shows different options (using a hand pump, pneumatic container pump or electric container pump) required as a minimum for designing a central lubrication system. Festo does not sell these additional components; however, they can be obtained from the following companies:

- Lincoln
- Bielomatik
- SKF (Vogel)

Festo recommends these companies because they can supply all the necessary components.

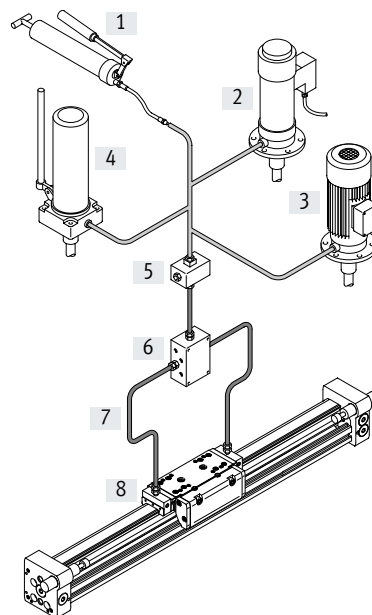

[1] Hand pump

[2] Pneumatic container pump

[3] Electric container pump

[4] Manually operated container pump

[5] Nipple block

[6] Distributor block

[7] Tubing or piping

[8] Fittings

Data sheet

Dimensions

Download CAD data → [www.festo.com](http://www.festo.com)

∅ 8 and 12

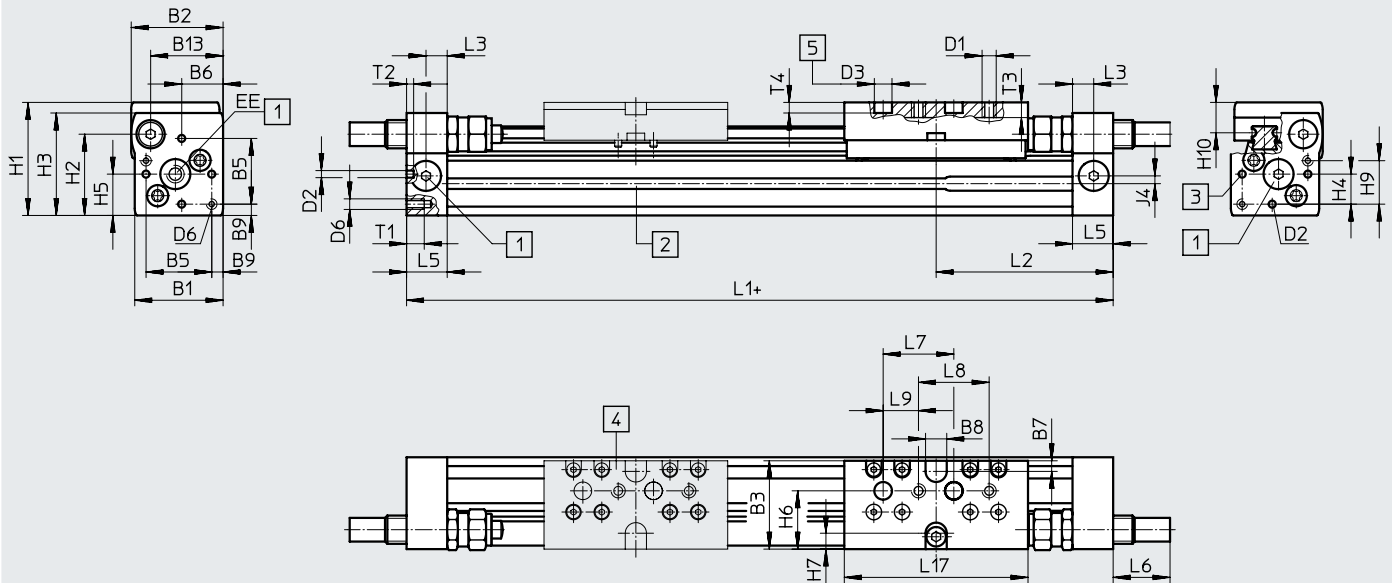

- + plus stroke length
- [1] Compressed air supply port options on 3 sides
- [2] Sensor slot for proximity sensor
- [3] Mounting hole for foot mounting or centring pin
- [4] Additional slide KL
- [5] Drilled hole for centring pin ZBS

∅	B1	B2	B3	B5	B6	B7	B8	B9	B13	D1	D2	D3	D6
[mm]							±0.05	±0.1			∅ H8	∅ H7	
8	25	26	25	18.6	11.7	3	6	3.2	20.5	M4	2	5	M3
12	30.2	31	31	20.6	13.5	3	8	4.8	25	M4	2	5	M4

∅	EE	H1	H2	H3	H4	H5	H6	H7	H9	H10	J4	L1	L2
[mm]													
8	M5	32	23	29	8.5	11.7	16.5	4.5	12.3	8.7	2.2	100	50.1
12	M5	37.5	28.5	34.5	8.7	13.5	20.5	5	14.7	9.8	3	125	62.4

∅	L3	L5	L6			L7	L8	L9	L17	T1	T2	T3	T4	Stroke tolerance
			P	YSR	YSRW									
[mm]						±0.03	±0.1	±0.1					+0.2	
8	6	11.4	0	16	16.2	20	20	10	52	5	2	4.3	3	0 ... 1.7
12	8	15.9	0	11.3	12.3	20	20	10	65	6	2	5	3	

Length tolerance		For stroke [mm]	
		≤ 1000	≤ 2000
L1	[mm]	+0.90	
		+1.10	

Profile barrel

∅ 8

∅ 12

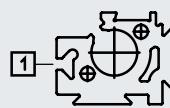

[1] Sensor slot for proximity sensor

Data sheet

Dimensions

Download CAD data → [www.festo.com](http://www.festo.com)

∅ 18 ... 40

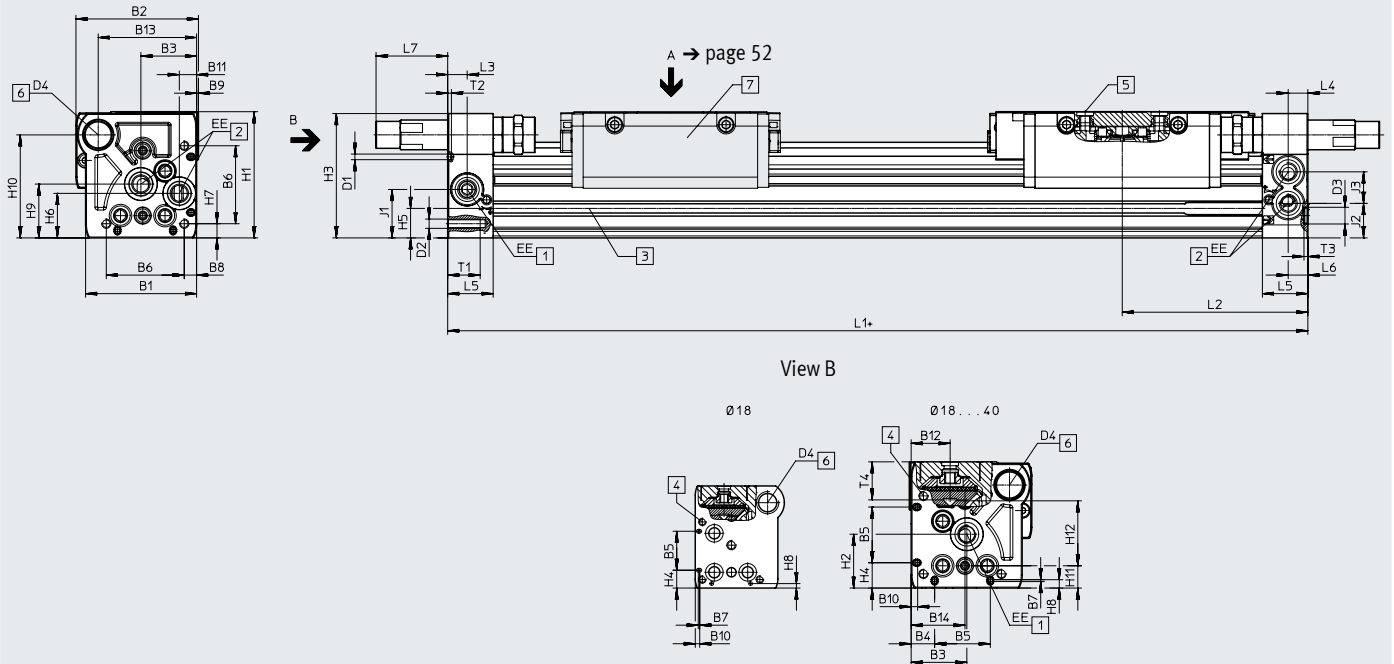

∅ 50/63

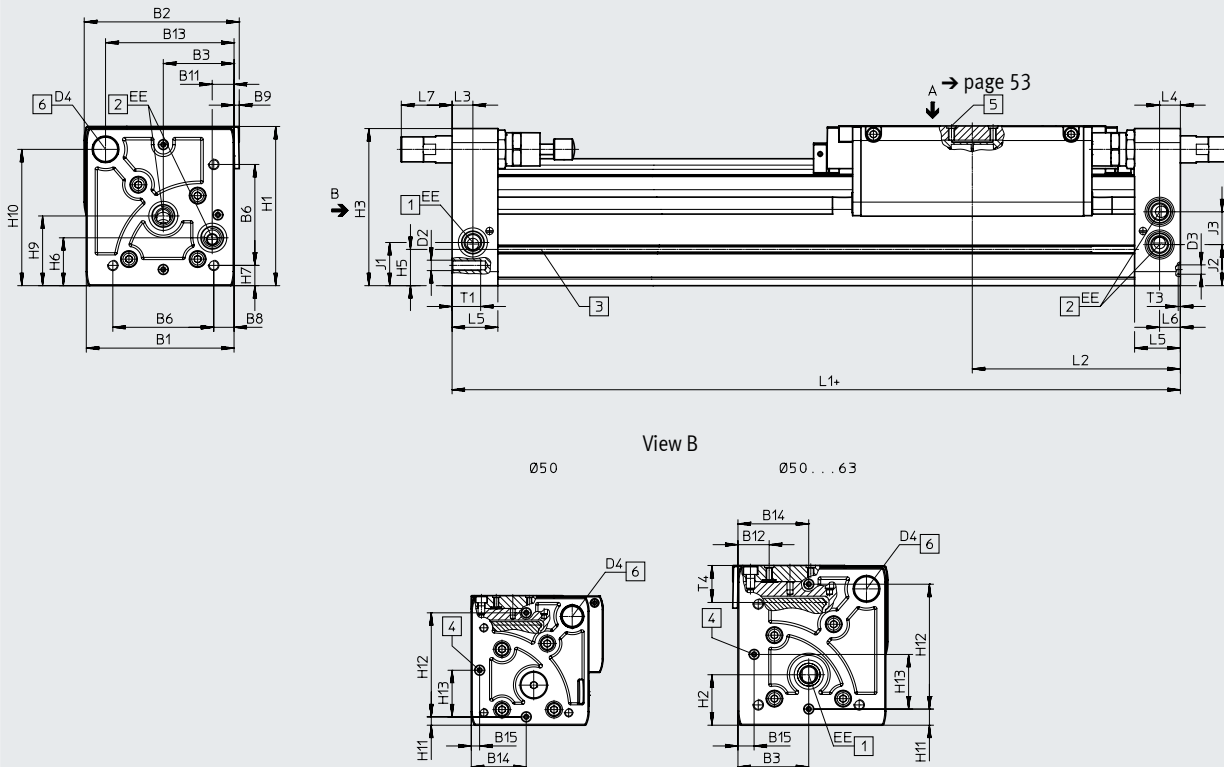

+ plus stroke length

- [1] Compressed air supply port options on 2 sides
- [2] Compressed air supply port options on 2 sides, for compressed air supply port at one end
- [3] Sensor slot for proximity sensor
- [4] Mounting hole for foot mounting HPC
- [5] Drilled hole for centring pin/sleeve
- [6] Thread for end stop
- [7] Additional slide

**Note**

The linear drive is actuated at the right end or at both ends by default. The linear drive can be actuated at the left end or at both ends by specifying the order code DL in the modular product system.

## Data sheet

∅	B1	B2	B3	B4	B5	B6	B7	B8	B9	B10	B11
[mm]			±0.05	±0.1	±0.05			±0.1			
18	44.5	49.9	19.5	8.8	21	31	0.8	3.8	1	2.4	5.5
25	59.8	66	30	12.65	30	42	1	6.65	1	3.5	9.3
32	73	79	38.5	5.7	63.1	57.5	–	8.5	1.5	14	14.9
40	91	98.5	45	17.2	55	65	–	12.2	2	8	16.5
50	113	126.5	52.8	–	–	81.6	–	12	–	–	21
63	142	149	68	–	–	97	–	19.5	5	–	21

∅	B12	B13	B14	B15	D1 ∅ ±0.05	D2	D3 ∅ H7	D4	EE	H1	H2
[mm]											
18	15.5	39	19.5	–	2	M4	5	M12x1	M5	56.3	23.1
25	21	53	29	–	3	M5	9	M16x1	G1/8	68	29
32	18	65	38.5	–	3	M6	9	M16x1	G1/8	78.5	30
40	24.5	80.5	45	–	4	M6	9	M22x1.5	G1/4	99.5	41.5
50	24	97	60	8	–	M8	9	M22x1.5	G1/4	124.5	38.5
63	30	123.5	68	15.5	–	M10	9	M26x1.5	G3/8	153.5	48.5

∅	H3	H4	H5	H6	H7	H8	H9	H10	H11	H12	H13
[mm]		±0.2								±0.05	
18	55	9.6	13.4	20	4.6	2.4	25.2	46	8.5±0.15	30	–
25	67	13.65	15.8	24	7.65	4.5	29	55.5	12±0.15	35	–
32	77	13.65	17	27.7	8.5	14	35.2	63.8	11.45±0.15	50	–
40	97.5	17.2	25	36.5	12.2	8	44	81.5	15±0.15	60	–
50	122.5	–	29.3	36	12	–	53	104.5	8±0.2	100±0.05	52.8
63	151	–	34.8	46	19.5	–	67	131	15.5±0.2	120±0.05	68

∅	J1	J2	J3	L1			L2	L3	L4		
				KF	KF-GP	1H-PN					
[mm]											
18	20	16.5	11	150	157	–	74.5	78	–	5.7	5.8
25	26.1	18.6	17	200	205	271	100	102.5	100	10.5	10.6
32	30	22	18.5	250	250	320.5	124.8	124.8	124.8	14.5	14.5
40	35	26	26	300	312	458	150	156	150	14.6	14.6
50	30.5	30.5	28	350	–	555.8	175	–	–	17	17
63	41.5	39.5	31.5	400	–	–	200	–	–	20	20

∅	L5	L6	L7			T1	T2	T3	T6	Stroke tolerance
			PPV	YSR	YSRW					
[mm]								+0.2		
18	15	5.5	0	29.9	32.4	9	2	3.1	15	0 ... 2.5
25	24.5	10.6	0	35.6	38.6	17.5	2	2.1	17.3	
32	30.5	14.5	0	19.5	28	15	2	2.1	20	
40	33.5	14.6	0	38.5	43.5	20	3	2.1	25.7	
50	41	17	0	31	36.3	24	–	2.1	28.75	
63	44	20	0	38.3	48.3	27.5	–	2.1	36.1	

 - Note

This product conforms to ISO 1179-1 and ISO 228-1.

Length tolerance		≤ 1000	≤ 2000	≤ 3000	≤ 4000	≤ 5000	≤ 6000	≤ 7000	≤ 8000	≤ 9000
For stroke	[mm]									
L1	[mm]	+0.90	+1.10	+1.40	+1.50	+1.60	+1.70	+2.20	+2.30	+2.40

Data sheet

Dimensions

Download CAD data → [www.festo.com](http://www.festo.com)

Slide

∅ 18

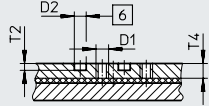

View A

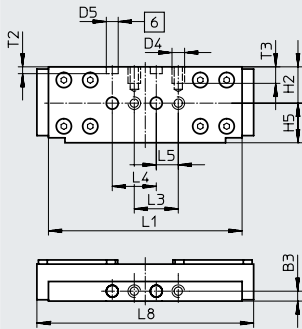

∅ 32

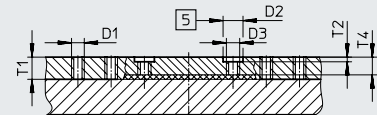

View A

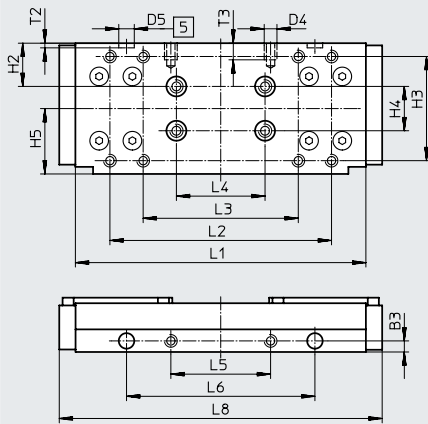

[5] Drilled hole for centring sleeve ZBH

[6] Drilled hole for centring pin ZBS

∅ 25

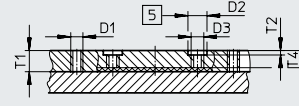

View A

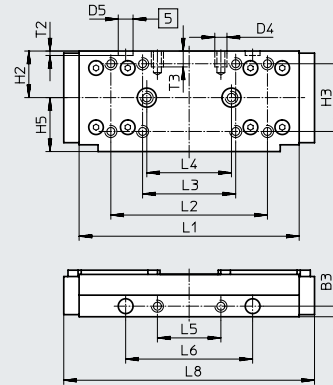

∅ 40

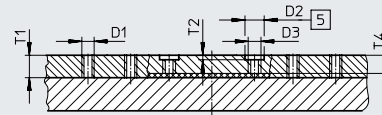

View A

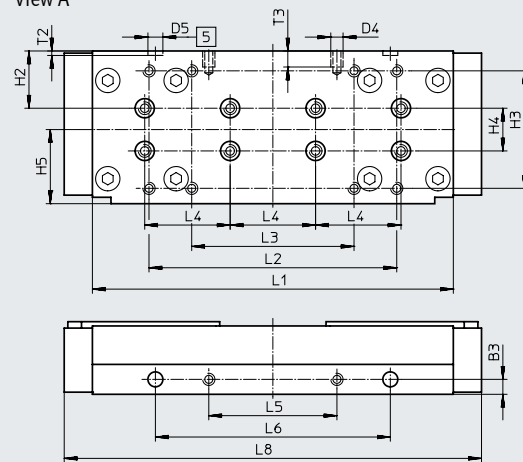

Data sheet

Dimensions

Download CAD data → [www.festo.com](http://www.festo.com)

Slide

∅ 50

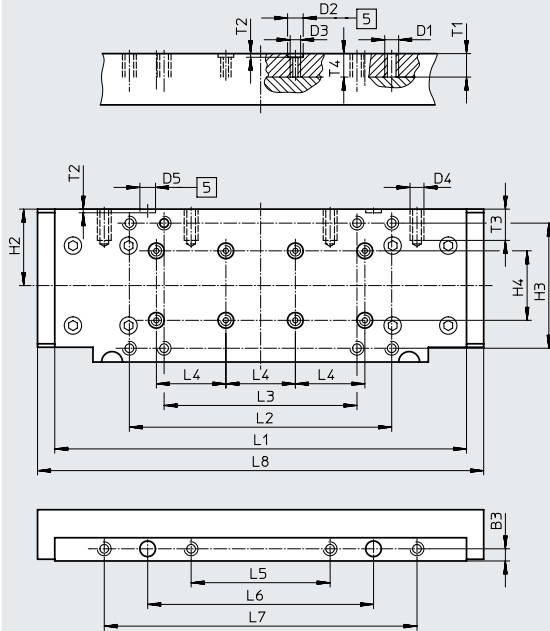

∅ 63

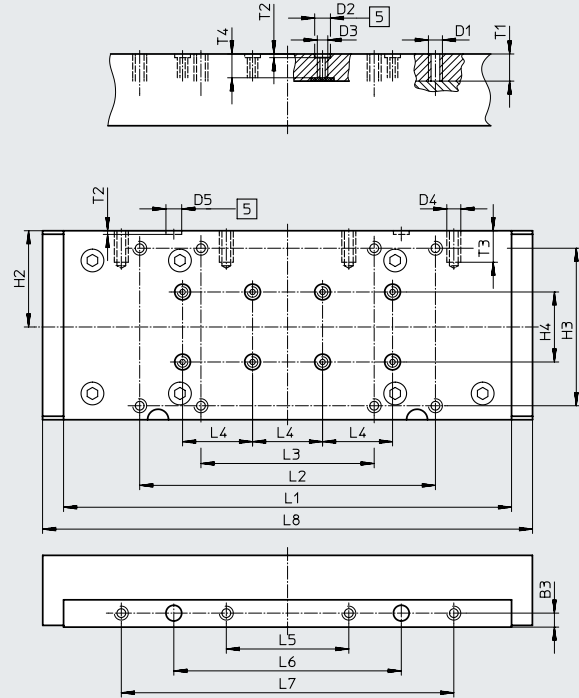

[5] Drilled hole for centring sleeve ZBH

∅	B3	D1	D2 ∅ H7	D3	D4	D5 ∅ H7	H2	H3	H4	H5	L1
[mm]	±0.05								±0.03	±0.1	
18	4.5	M5	5	–	M5	5	16.5	–	–	18	88±0.1
25	5	M5	9	M6	M5	7	22	32±0.2	–	25.5	104±0.2
32	5	M5	9	M6	M5	7	19.5	47±0.2	20	29.5	131±0.2
40	7	M5	9	M6	M6	7	26.8	55±0.2	20	34.7	169±0.2
50	7	M8	9	M6	M8	9	44	72±0.3	40	–	237±0.1
63	8	M8	9	M6	M8	9	55	90±0.3	40	–	256±0.1

∅	L2	L3	L4	L5	L6	L7	L8	T1	T2	T3	T4
[mm]	±0.2		±0.03	±0.1	±0.05	±0.1					
18	–	20±0.1	20	10	–	–	99	–	3.1±0.1	7.5	6.7
25	74	44±0.2	40	30	60	–	118.5	10	2.1±0.2	7.5	8
32	100	70±0.2	40	45	85	–	145.7	10	2.1±0.2	7.5	8
40	116	76±0.2	40	60	110	–	195.4	10.5	2.1±0.2	7.5	8.5
50	151	111±0.2	40	80	130	180	256.8	13.5	2.1±0.2	18	13.5
63	169	99±0.2	40	70	130	190	280	15.5	2.1±0.2	18	13.6

Data sheet

Dimensions

Download CAD data → [www.festo.com](http://www.festo.com)

Slide, variant GP – Protected recirculating ball bearing guide

∅ 18

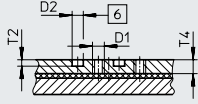

View A

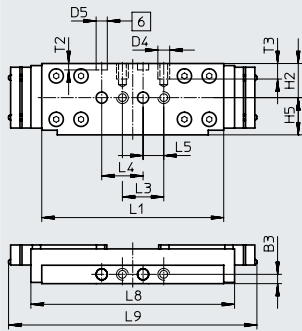

∅ 32

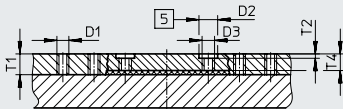

View A

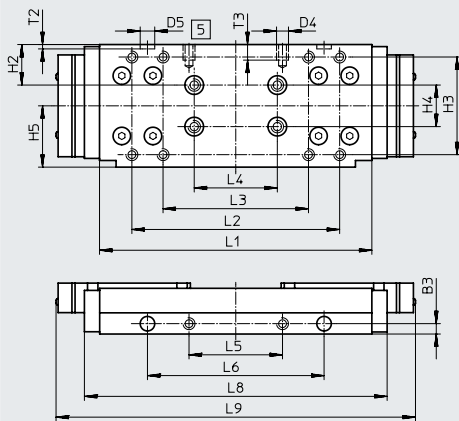

- [5] Drilled hole for centring sleeve ZBH
- [6] Drilled hole for centring pin ZBS

∅ 25

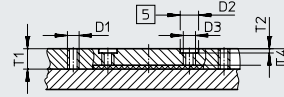

View A

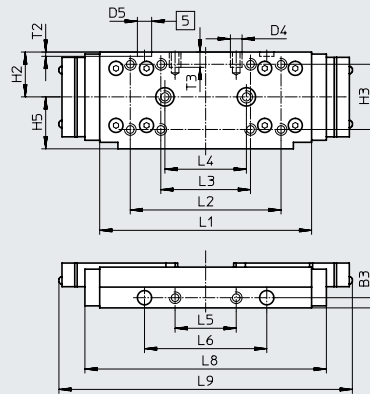

∅ 40

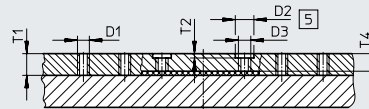

View A

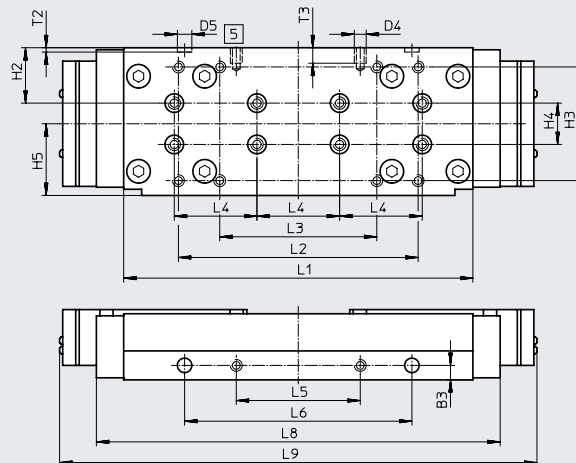

## Data sheet

∅ [mm]	B3 ±0.05	D1	D2 ∅ H7	D3	D4	D5 ∅ H7	H2	H3
18	4.5	M5	5	–	M5	5	16.5	–
25	5	M5	9	M6	M5	7	22	32±0.2
32	5	M5	9	M6	M5	7	19.5	47±0.2
40	7	M5	9	M6	M6	7	26.8	55±0.2

∅ [mm]	H4 ±0.03	H5 ±0.1	L1	L2 ±0.2	L3	L4 ±0.03	L5 ±0.1	L6 ±0.05
18	–	18	88±0.1	–	20±0.1	20	10	–
25	–	25.5	104±0.2	74	44±0.2	40	30	60
32	20	29.5	131±0.2	100	70±0.2	40	45	85
40	20	34.7	169±0.2	116	76±0.2	40	60	110

∅ [mm]	L7 ±0.1	L8	L9	T1	T2	T3	T4
18	–	99	120	–	3.1±0.1	7.5	6.7
25	–	118.5	144	10	2.1±0.2	7.5	8
32	–	145.7	173	10	2.1±0.2	7.5	8
40	–	195.4	231	10.5	2.1±0.2	7.5	8.5

Data sheet

Dimensions

Download CAD data → [www.festo.com](http://www.festo.com)

Slide, variant C – Lubrication adapter

∅ 25

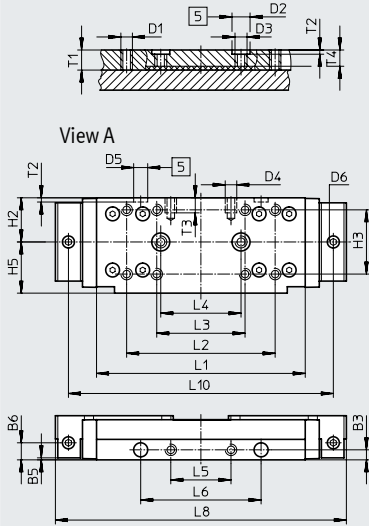

∅ 32

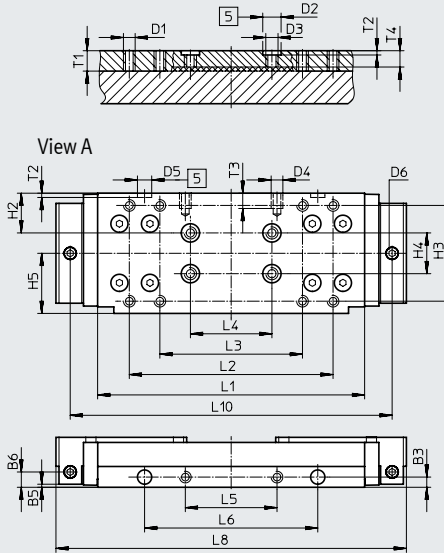

∅ 40

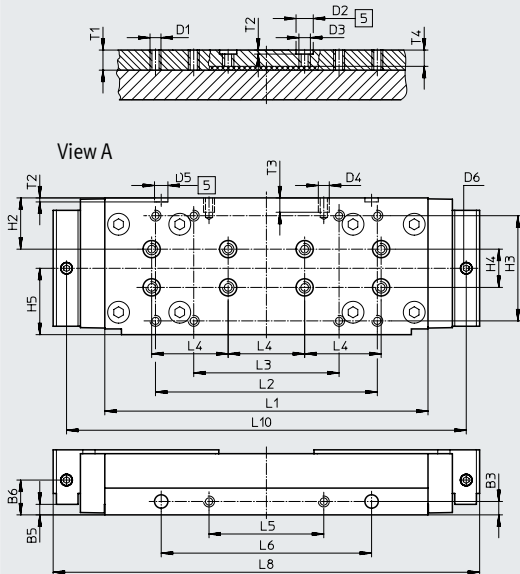

∅ 63

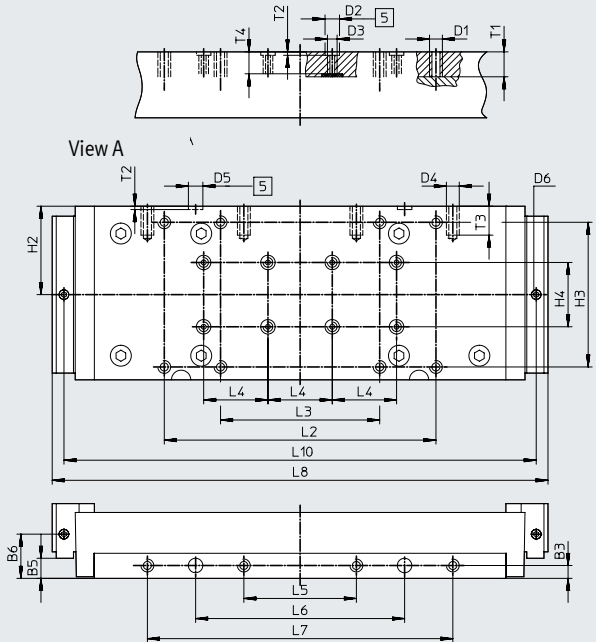

[5] Drilled hole for centring sleeve ZBH

Data sheet

∅	B3	B5	B6	D1	D2 ∅ H7	D3	D4	D5 ∅ H7	D6	H2	H3	H4	H5
[mm]	±0.05	±0.05										±0.03	±0.1
25	5	1	8.5	M5	9	M6	M5	7	M6x1	22	32±0.2	–	25.5
32	5	1.5	7.5	M5	9	M6	M5	7	M6x1	19.5	47±0.2	20	29.5
40	7	18.2	18.2	M5	9	M6	M6	7	M6x1	26.8	55±0.2	20	34.7
63	8	12.5	27.5	M8	9	M6	M8	9	M6x1	55	90±0.3	40	–

∅	L1	L2	L3	L4	L5	L6	L7	L8	L10	T1	T2	T3	T4
[mm]		±0.2	±0.2	±0.03	±0.1	±0.05	±0.1				±0.2		
25	104±0.2	74	44	40	30	60	–	145	132	10	2.1	7.5	8
32	131±0.2	100	70	40	45	85	–	172	158	10	2.1	7.5	8
40	169±0.2	116	76	40	60	110	–	224.4	210.4	10.5	2.1	7.5	8.5
63	256±0.1	169	99	40	70	130	190	308.4	293.8	15.5	2.1	18	13.6

Profile barrel

∅ 18

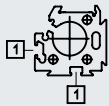

∅ 25

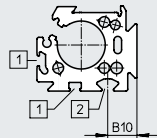

∅ 32

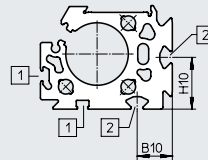

∅ 40

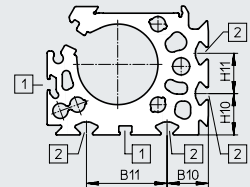

∅ 50

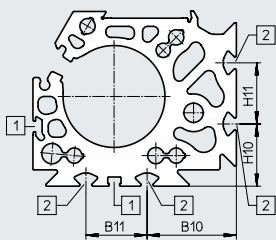

∅ 63

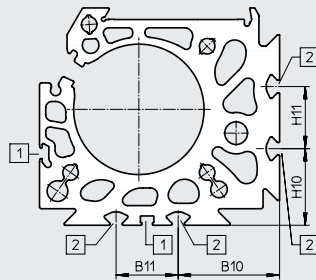

- [1] Sensor slot for proximity sensor
- [2] Mounting slot for slot nut

∅	B10	B11	H10	H11
[mm]				
25	15.23	–	–	–
32	18	–	26.5	–
40	20.5	40	20.5	20
50	43.8	30	30.5	30
63	49	30	37	30

Data sheet

**Dimensions**

Download CAD data → [www.festo.com](http://www.festo.com)

1H – With clamping unit

∅ 25/32

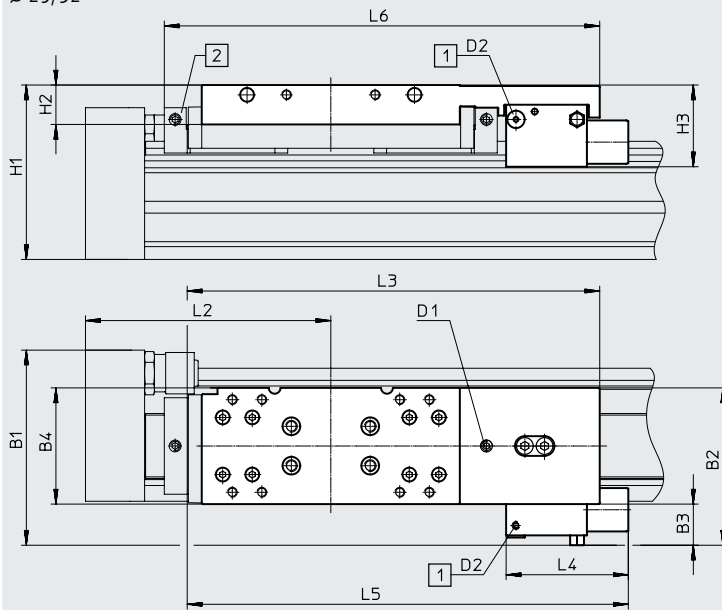

- **Note**

Overall length L1 at stroke = 0 mm

→ page 50

[1] Compressed air supply port

[2] Lubrication adapter

Type	B1	B2	B3	B4	H1	H2	H3	D1	D2	L2	L3	L4	L5	L6
DGC-25-...-1H-PN	83.6	64.9	17.6	47.5	79	21	39.5	M6	M5	100	182.3	63	198	-
DGC-25-...-C-1H-PN														193.8
DGC-32-...-1H-PN	99.9	79.9	20.9	59	88.5	20	41.5	M6	M5	124.8	209.4	62	223.9	-
DGC-32-...-C-1H-PN														221

Data sheet

Dimensions

Download CAD data → [www.festo.com](http://www.festo.com)

1H – With clamping unit

∅ 40/50

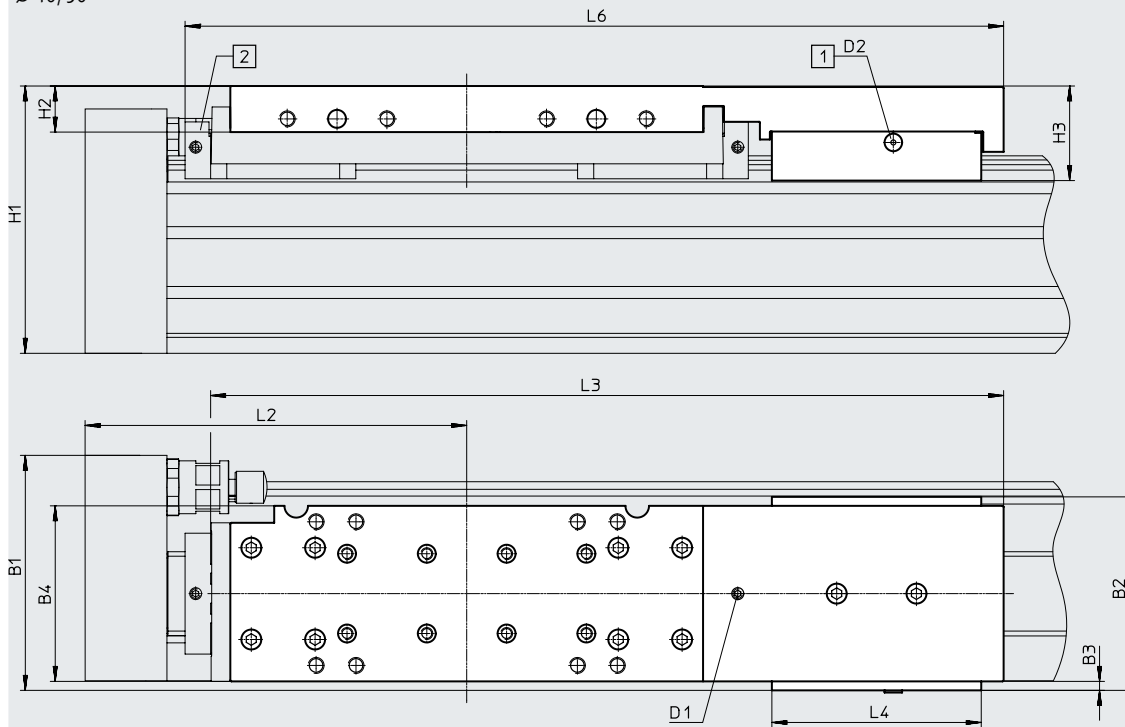

Note

Overall length L1 at stroke = 0 mm

→ page 50

[1] Compressed air supply port

[2] Lubrication adapter

Type	B1	B2	B3	B4	H1	H2	H3	D1	D2	L2	L3	L4	L6
DGC-40-...-1H-PN	109.9	97	11.7	69.4	113.5	28	48.9	M6	M5	150	331.2	105	-
DGC-40-...-C-1H-PN													345.7
DGC-50-...-1H-PN	117.8	97	4.5	88	134	23	47.4	M6	M5	191.3	397.6	105	-
DGC-50-...-C-1H-PN													412.1

## Ordering data – Modular product system

### Order code

 **Note**

1) End stops or shock absorbers must not be removed.

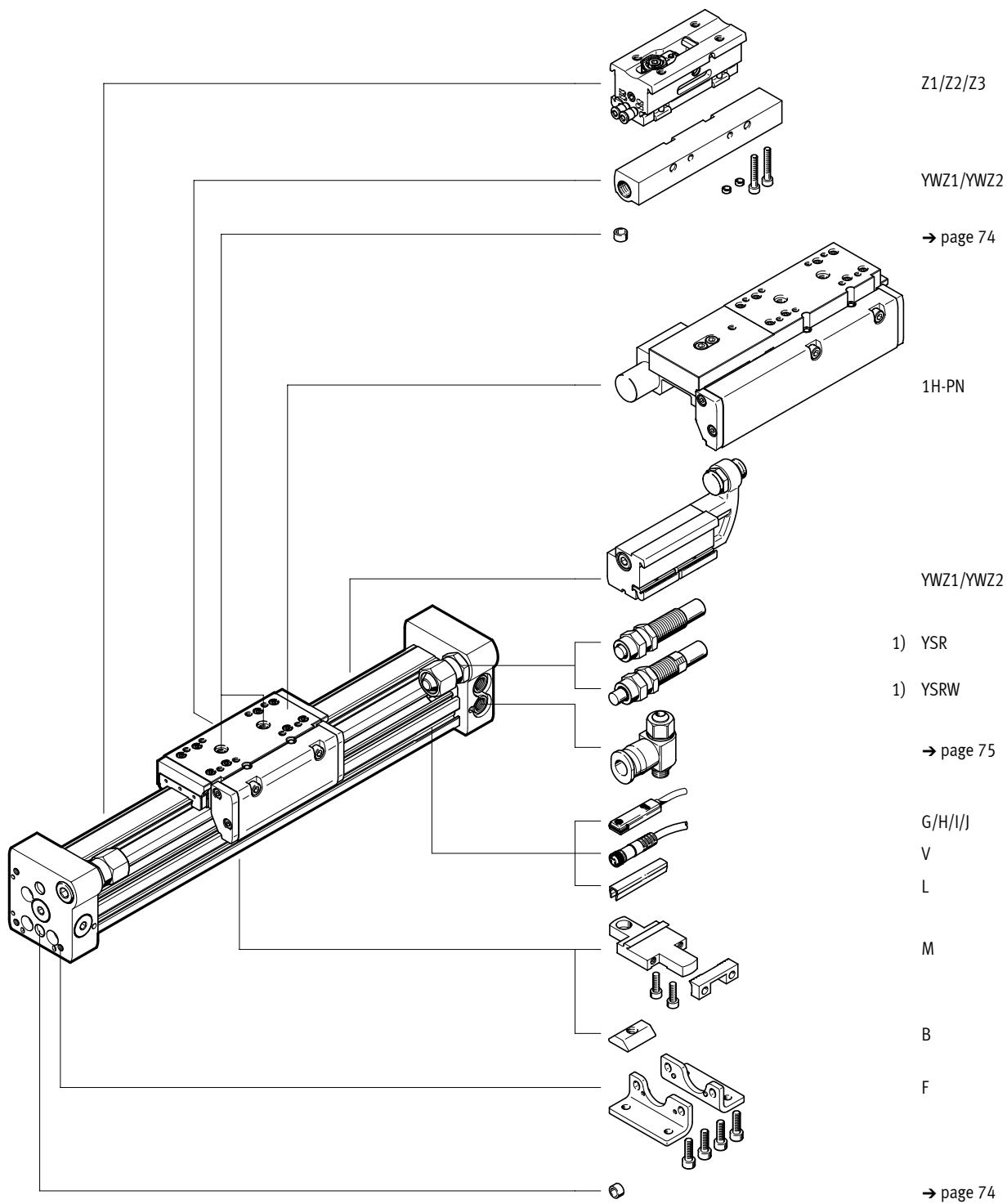

## Ordering data – Modular product system

### Order code

KL/KR – With additional slide

GP – With protected recirculating ball bearing guide

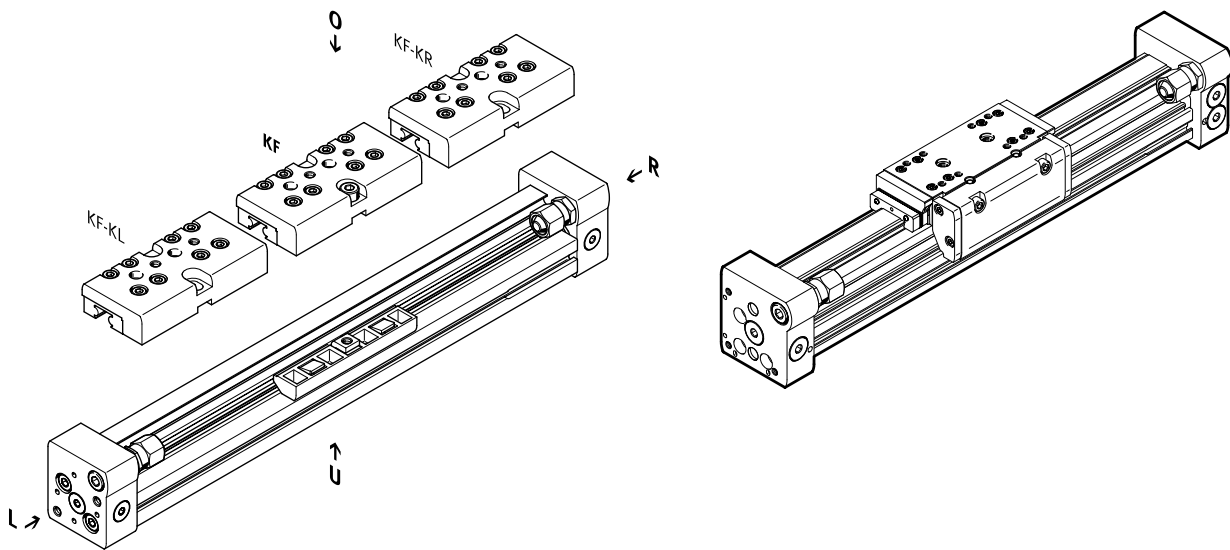

### Working stroke reduction when ordering an additional slide KL or KR

For a linear drive DGC with additional slide, the working stroke is reduced by the length of the additional slide and the distance between both slides.

Assuming:  
DGC-12-500-...  
L = 20 mm  
L17 = 65 mm

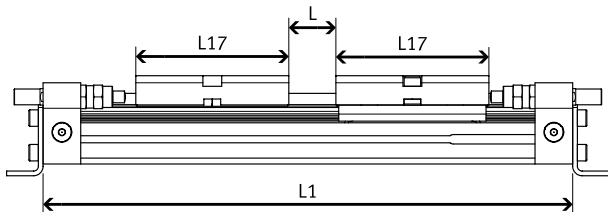

∅ [mm]	8	12	18	25	32	40	50	63
L17	52	65	99	118.5	145.7	195.4	256.8	280

The working stroke is reduced to  
415 mm = 500 mm – 20 mm – 65 mm

Ordering data – Modular product system

Ordering table											
Size	8	12	18	25	32	40	50	63	Condi- tions	Code	Enter code
Module no.	<b>530906</b>	<b>530907</b>	<b>532446</b>	<b>532447</b>	<b>532448</b>	<b>532449</b>	<b>532450</b>	<b>532451</b>			
Function	Linear drive									DGC	DGC
Piston diameter [mm]	8	12	18	25	32	40	50	63		☆ -...	
Stroke [mm]	1 ... 1300	1 ... 1900	1 ... 3000	1 ... 8500			1 ... 5000			☆ -...	
Guide	Recirculating ball bearing guide									☆ -KF	-KF
Cushioning	Elastic cushioning rings/ plates at both ends		-	-	-	-	-	-		☆ -P	
	-	-	Pneumatic cushioning, adjustable at both ends							☆ -PPV	
	Shock absorber, self-adjusting									☆ -YSR	
	Shock absorber, self-adjusting, progressive									☆ -YSRW	
Position sensing	Via proximity sensor									☆ -A	-A
Compressed air supply port	At the right end or at both ends									☆	
	-	-	At the left end or at both ends							-DL	
Slide	-	-	Protected recirculating ball bearing guide				-	-	[1]	-GP	
Lubrication	-	-	Standard							☆	
	-	-	Lubrication approved for use in food applications						[2]	-H1	
Lubrication function	Standard									☆	
	-	-	-	Lubrication adapter					[3]	-C	
Additional slide on left	Additional slide, standard, on left								[4]	-KL	
Additional slide on right	Additional slide, standard, on right								[4]	-KR	
Clamping unit	-	-	-	Without				-		☆	
	-	-	-	1-channel				-	[5]	-1H	
Actuation type	-	-	-	Without				-		☆	
	-	-	-	Pneumatic				-	[5]	-PN	
EU certification	Without									☆	
	II 3GD								[6]	-EX2	
	II 2G								[6]	-EX3	

- [1] GP Not with cushioning YSR, YSRW  
Not with additional slide KL, KR
- [2] H1 Not with protected version GP, cushioning YSR, YSRW or clamping unit 1H
- [3] C Not with slide GP  
For size 50, only with clamping unit 1H
- [4] KL, KR For a linear drive DGC with additional slide, the working stroke is reduced by the length of the additional slide and the distance between both slides.  
Not with cushioning PPV
- [5] 1H, PN Not with intermediate-position module Z1, Z2, Z3; end-position limiter YWZ1, YWZ2; protected version GP; additional slide KL, KR or lubrication H1  
Only with cushioning YSRW  
1H only with PN
- [6] EX2, EX3 Not with protected recirculating ball bearing guide GP, lubrication adapter C, clamping unit 1H-PN, proximity sensor G, H, I, J, connecting cable V, intermediate-position module Z1, Z2, Z3

Festo core product range ★ Generally ready for dispatch from the factory within 24 hours  
★ Generally ready for dispatch from the factory within 5 days

## Ordering data – Modular product system

Ordering table		8	12	18	25	32	40	50	63	Condi- tions	Code	Enter code	
Accessories		Enclosed separately (can be retrofitted)										ZUB-	ZUB-
Foot mounting		1										F	
Profile mounting		1 ... 9										...M	
Slot nut for mounting slot		-	-	-	1 ... 9						...B		
Proximity sensor	2.5 m cable	1 ... 9										...G	
	Plug M8	1 ... 9										...H	
Proximity sensor, contactless, PNP	2.5 m cable	1 ... 9										...I	
	Plug M8	1 ... 9										...J	
Connecting cable	M8, 2.5 m	1 ... 9										...V	
Slot cover for sensor slot		-	-	1 ... 9						...L			
Mechanical end-position limiter		-	-	Variable end position, at one end					[7]	YWZ1			
		-	-	Variable end position, at both ends					[7]	YWZ2			
Intermediate-position module		-	-	-	1 intermediate position		-	-	[8]	-Z1			
		-	-	-	2 intermediate positions		-	-	[8]	-Z2			
		-	-	-	3 intermediate positions		-	-	[8]	-Z3			
Operating instructions		Express waiver – no operating instructions to be included (already available)										-O	

[7] YWZ1, YWZ2 Only with cushioning YSR or YSRW

[8] YWZ1, YWZ2 Only with cushioning YSR or YSRW and mechanical end-position limiter YWZ1 or YWZ2

## Accessories

**Foot mounting HPC**  
(order code: F)

Material:  
Galvanised steel

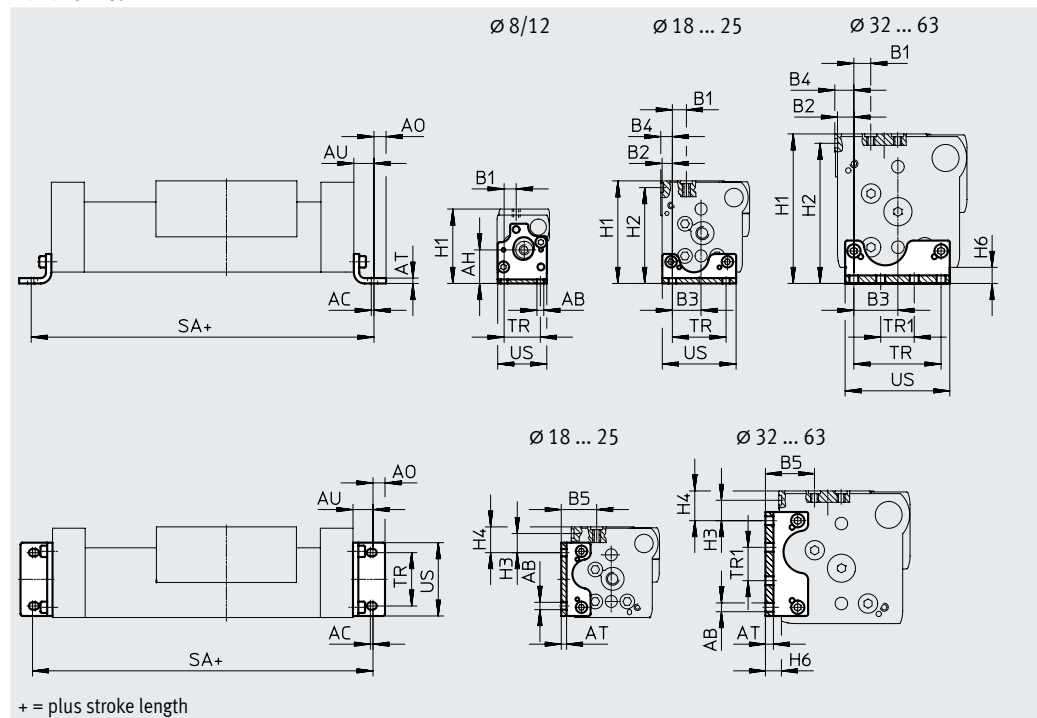

### Dimensions and ordering data

For diam.	AB $\varnothing$	AC	AH	AO	AT	AU	B1		B2
							G	GF/KF	
[mm]									
8	3.4	1.5	16.7	3	2	9	6	6	-
12	4.5	2	18.5	4.5	2	11.5	5.4	5.4	-
18	5.5	2	-	6.75	3	13.25	15	11.2	4.3
25	5.5	2	-	9	4	15	12.5	13.35	7.65
32	6.6	2	-	10	5	19	11.5	9	9
40	6.6	2	-	10	6	20	7.6	12.6	12.2
50	9	3	-	11	8	25	12.5	12.5	11.5
63	11	3	-	13.5	8	28	17.5	17.5	12.5

For diam.	B3	B4		B5		H1	
		GF	KF	G	GF/KF	G	GF/KF
[mm]							
8	-	-	-	-	-	37	37
12	-	-	-	-	-	42.5	42.5
18	15.2	-	5.3	27	23.2	57.5	64
25	21.35	-	8.65	28.65	29.5	67	76.5
32	29.5	-	10.5	29.5	27	82	87.5
40	32.8	-	14.2	31.8	36.8	100	111.5
50	48.5	11.5	11.5	41	41	137	141.5
63	55.5	6.5	17.5	49	49	159	172.5

## Accessories

Dimensions and ordering data							
For diam.	H2	H3	H4		H6	SA	
[mm]	GF/KF	GF/KF	G	GF/KF		G/GF/KF	KF-GP
8	–	–	–	–	5	118 <sub>-0.2</sub>	–
12	–	–	–	–	5	148 <sub>-0.2</sub>	–
18	59.5	16	14	21.2	7.7	176.5 <sub>-0.2</sub>	183.5 <sub>-0.2</sub>
25	71.5	14.35	9.85	19.35	8.5	230 <sub>-0.2</sub>	235 <sub>-0.2</sub>
32	82.5	8	7.5	13	9	288 <sub>-0.2</sub>	288 <sub>-0.2</sub>
40	104.5	15.3	10.8	22.3	12	340 <sub>-0.2</sub>	352 <sub>-0.2</sub>
50	134.5	23.4	25.9	30.4	17	400 <sub>-0.2</sub>	–
63	164.5	22	24	30	19	456 <sub>-0.2</sub>	–

For diam.	TR	TR1	US	Weight	Part no.	Type <sup>1)</sup>
[mm]	±0.1	±0.1		[g]		
8	18	–	24.4	25	<b>526385</b>	<b>HPC-8</b>
12	20	–	29.6	41	<b>526388</b>	<b>HPC-12</b>
18	30	–	38.6	58	<b>533667</b>	<b>HPC-18</b>
25	40	–	55	131	<b>533668</b>	<b>HPC-25</b>
32	56.5	19.5	68	239	<b>533669</b>	<b>HPC-32</b>
40	65	25	78	348	<b>533670</b>	<b>HPC-40</b>
50	82.6	47.4	102	754	<b>545236</b>	<b>HPC-50</b>
63	111	39	133	1245	<b>545237</b>	<b>HPC-63</b>

1) Suitable for ATEX

## Accessories

**Profile mounting MUC**  
(order code: M)

Material:  
High-alloy steel

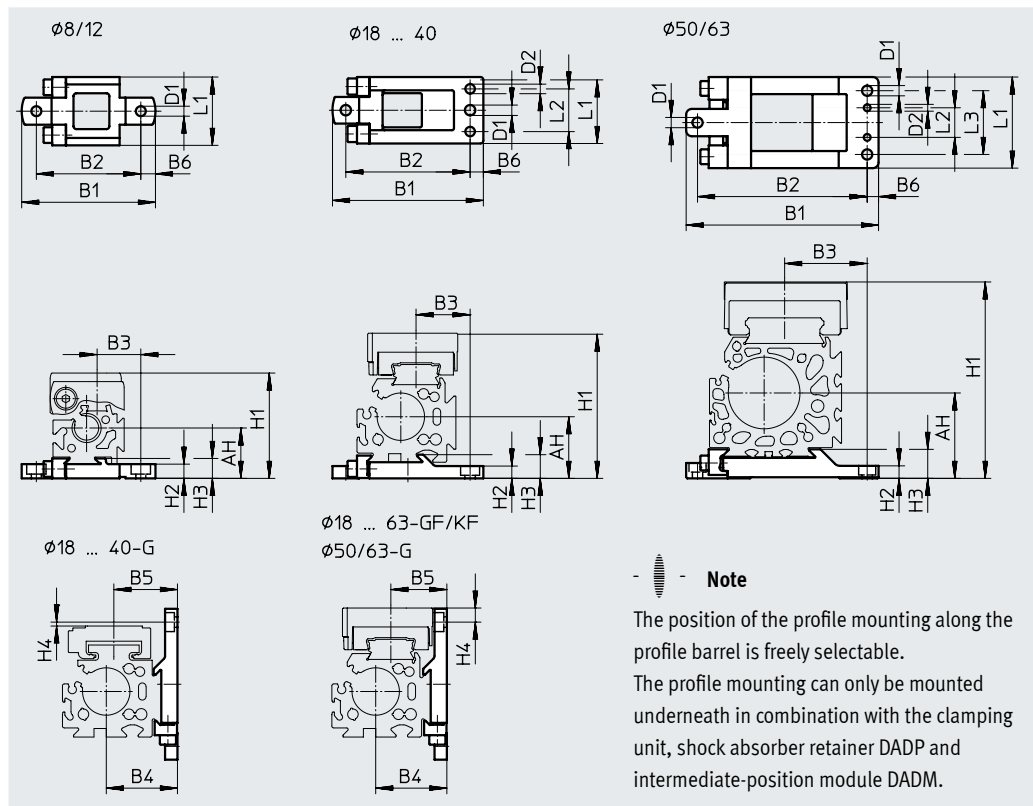

**Note**  
The position of the profile mounting along the profile barrel is freely selectable.  
The profile mounting can only be mounted underneath in combination with the clamping unit, shock absorber retainer DADP and intermediate-position module DADM.

**Dimensions and ordering data**

For diam. [mm]	AH	B1	B2	B3		B4
				G	GF/KF	
8	17.7	47	36.7	15.35	15.35	-
12	18.5	52.5	42.2	16.5	16.5	-
18	27.2	67.8±0.2	56±0.15	30.5	28.7	27.2
25	32.5	79.5±0.2	65.5±0.15	32.5	28.5	37.5
32	37.5	94±0.2	80±0.15	35	35	47.5
40	47	110.5±0.2	96±0.15	43	43	57
50	61	145±0.5	125±0.2	56	56	77
63	75	169±0.5	149±0.2	72.5	72.5	87

For diam. [mm]	B5		B6	D1 ø H13	D2 ø H7	H1		
	G	GF/KF				G	GF/KF	1H-PN
8	-	-	5.1	3.5	-	37	37	-
12	-	-	5.1	3.5	-	42.5	42.5	-
18	25	23.2	5.7	5.5	5	57.5	64	-
25	33.5	29.5	7	5.5	5	67	76.5	87.5
32	37	37	7	5.5	5	82	87.5	97.5
40	46.8	46.8	7	6.5	6	100	111.5	125.5
50	61	61	7	9	6	137	141.5	151
63	69	69	10	9	6	159	172.5	-

## Accessories

Dimensions and ordering data					
For diam.	H2	H3	H4		L1
[mm]			G	GF/KF	
8	5	7	–	–	24
12	4.5	7	–	–	24
18	5.7 <sub>-0.2</sub>	9.9±0.1	0.1	6.4	33±0.1
25	6.5 <sub>-0.2</sub>	12.5±0.1	2.07	7.43	35±0.1
32	6.5 <sub>-0.2</sub>	13±0.1	1.5	4	45±0.1
40	8.5 <sub>-0.2</sub>	16±0.1	0.2	11.3	60±0.1
50	11	23.5	4.7	9.2	80±0.4
63	11	25.5	1.5	15	80±0.4

For diam.	L2	L3	Weight	Part no.	Type <sup>1)</sup>
[mm]	±0.05	±0.2	[g]		
8	–	–	28	526384	MUC-8
12	–	–	32	526387	MUC-12
18	20.5	–	78	531752	MUC-18
25	22.5	–	113	531753	MUC-25
32	30	–	174	531754	MUC-32
40	44	–	346	531755	MUC-40
50	26	56	874	531756	MUC-50
63	26	56	1080	531757	MUC-63

1) Suitable for ATEX

Accessories

**Moment compensator FKC**

(order code: FK)  
for DGC-G

Materials:

Plate: wrought aluminium alloy

Articulated joint: polyamide

Ball stud: high-alloy steel

For diam. 8 ... 40

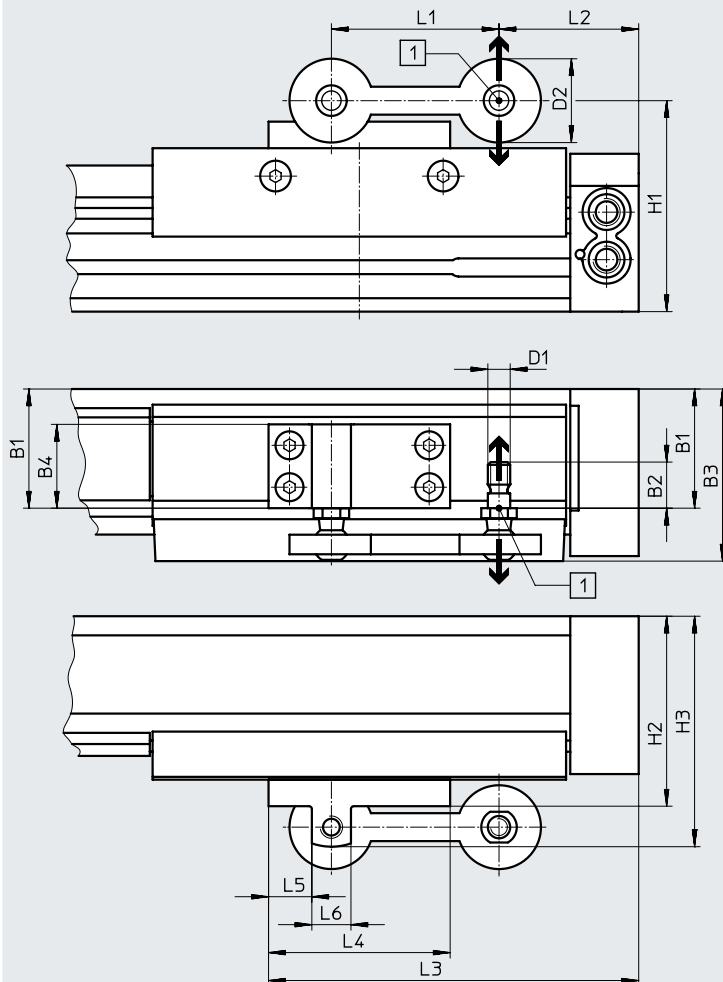

 **Note**

Compensation possible in direction of arrow.

[1] Max. offset:

With diam. 8 ... 40: ±2.5 mm

With diam. 50/63: ±4 mm

For diam. 50/63

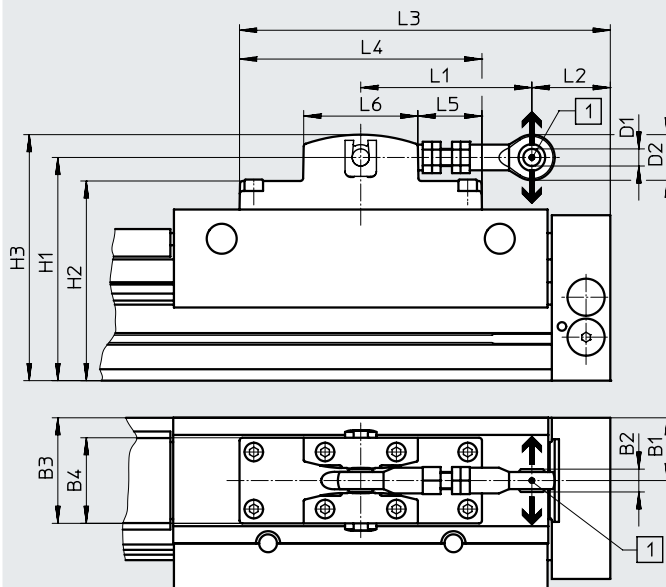

## Accessories

Dimensions and ordering data				
For diam.	Max. offset between linear drive and external guide [mm]	Max. permissible load in direction of force		Ambient temperature [°C]
[mm]		[N]		
8	±2.5	550	Backlash-free	-10 ... +60
12		550	Backlash-free	
18		1400	Backlash-free	
25		1400	Backlash-free	
32		1400	Backlash-free	
40		1400	Backlash-free	
50	±4	5000	Low backlash	
63		5000	Low backlash	

For diam.	B1	B2	B3	B4	D1	D2	H1	H2	H3	L1
[mm]										
8	17.5	10.2	30	16	M5	20	43.5	42	48	40
12	18.5	10.2	31	16	M5	20	49	47.5	53.5	40
18	29.3	16.5	47.8	20	M8	30	66.8	59.8	73.8	60
25	42.65	16.5	61.15	30	M8	30	75.5	68	82.5	60
32	43	16.5	61.5	30	M8	30	90	82.5	97	60
40	57.3	16.5	75.8	45	M8	30	105	97.5	113	60
50	44	16	74	60	12 <sup>H7</sup>	32	156.5	140	172.4	120 ... 125
63	50	16	80	60	12 <sup>H7</sup>	32	176.5	161.5	192.4	120 ... 125

For diam.	L2	L3	L4	L5	L6	CRC <sup>1)</sup>	Weight	Part no.	Type
[mm]							[g]		
8	5.1	62.6	35	13	9	1	29	529350	FKC-8/12
12	17.1	74.6	35	13	9		29	529350	FKC-8/12
18	24.5	107	65	15.5	14		97	538714	FKC-18
25	50	132.5	65	15.5	14		119	538715	FKC-25
32	77.5	162	75	17.5	14		122	538961	FKC-32
40	103	187.5	75	17.5	14		180	538962	FKC-40
50	50 ... 55	260	170	45	80		1200	545240	FKC-50/63
63	75 ... 80	260	170	45	80		1200	545240	FKC-50/63

1) Corrosion resistance class CRC 1 to Festo standard FN 940070  
 Low corrosion stress. Dry indoor application or transport and storage protection. Also applies to parts behind coverings, in the non-visible interior area, and parts which are covered in the application (e.g. drive trunnions).

## Accessories

### Shock absorber retainer DADP-DGC

#### Stop KYC

(order code: YWZ1 or YWZ2)  
for DGC-GF, DGC-KF, DGC-FA

#### Materials:

Shock absorber retainer, housing:  
anodised aluminium  
Free of copper and PTFE

#### Materials:

Stop, housing: anodised aluminium  
Stop bracket: stainless steel casting  
Clamp: high-alloy steel  
Free of copper and PTFE

Shock absorber retainer DADP

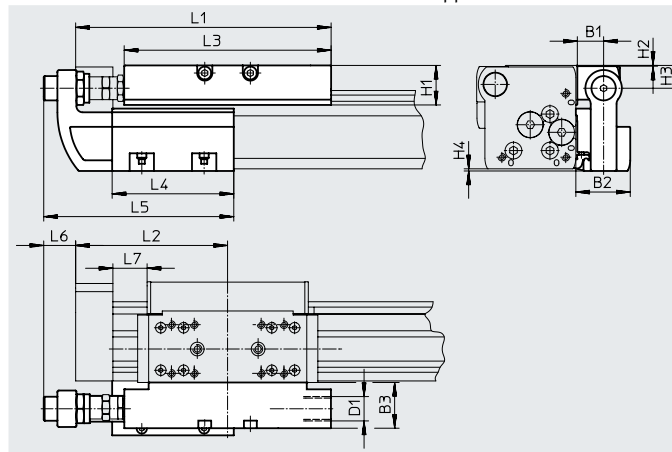

**Note**  
Shock absorbers are not included in the scope of delivery. Existing shock absorbers can be removed from the end caps of the linear drive and installed in the shock absorber retainer. Under no circumstances may the linear drive and the intermediate-position module be operated without a shock absorber.

Dimensions		B1	B2	B3	H1	H2	H3	H4
For diam. [mm]								
18	GF	16	34.5	29	20.7	0.2	12.5	0.7
	KF							
25	GF	16.5	35	28	25.5	0.5	15	1.4
	KF			30				
32	GF	16.5	35	28	25.5	0.5	15	1.7
	KF			30				
40	GF	16	35.7	29	32	0.5	21.5	1.6
	KF			35				37
50	GF	25	50	41	40.5	0.5	24	0
	KF							
63	GF	25	50	40	51.5	1.5	33	0
	KF							

For diam. [mm]		L1	L2	L3	L4	L5	L6	L7 min.
18	GF	128	74.5	107	80	118.5	23.5	14.5
	KF							
25	GF	168	100	136	80	125	20.5	22.5
	KF							
32	GF	206.8	124.8	164	120	165	14.5	42.8
	KF							27.3
40	GF	255	150	210	156	220.5	31	30.8
	KF							31
50	GF	301	175	252	170	238	27	31
	KF							
63	GF	328	200	256	200	268	24	41
	KF							

## Accessories

### Technical data and ordering data

#### Precision adjustment

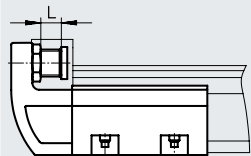

**Note**

The stop KYC can be used in both directions.

#### Mounting example

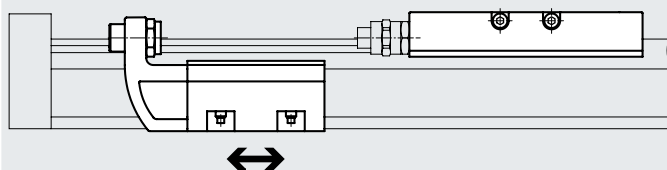

**Note**

The stop KYC can be mounted at any position along the stroke.

For diam. [mm]	Max. impact force [N]	Ambient temperature [°C]	CRC <sup>1)</sup>	Weight [g]	Part no.	Type <sup>2)</sup>
<b>Shock absorber retainer</b>						
18	GF 1100 KF	-10 ... +80	2	140	541725	DADP-DGC-18-GF
				130	541729	DADP-DGC-18-KF
25	GF 1400 KF			205	541726	DADP-DGC-25-GF
				180	541730	DADP-DGC-25-KF
32	GF 1700 KF			225	541727	DADP-DGC-32-GF
				215	541731	DADP-DGC-32-KF
40	GF 3500 KF			380	541728	DADP-DGC-40-GF
				460	541732	DADP-DGC-40-KF
50	GF 3500 KF			890	545244	DADP-DGC-50
63	GF 4300 KF			1080	545245	DADP-DGC-63

1) Corrosion resistance class CRC 2 to Festo standard FN 940070

Moderate corrosion stress. Indoor applications in which condensation can occur. External visible parts with primarily decorative surface requirements which are in direct contact with a normal industrial environment.

2) Suitable for ATEX

For diam. [mm]	Precision adjustment L [mm]	Ambient temperature [°C]	CRC <sup>1)</sup>	Weight [g]	Part no.	Type <sup>2)</sup>
<b>Stop</b>						
18	10	-10 ... +80	2	400	541691	KYC-18
25	10			560	541692	KYC-25
32	10			790	541693	KYC-32
40	15			1525	541694	KYC-40
50	15			2270	545242	KYC-50
63	15			2950	545243	KYC-63

1) Corrosion resistance class CRC 2 to Festo standard FN 940070

Moderate corrosion stress. Indoor applications in which condensation can occur. External visible parts with primarily decorative surface requirements which are in direct contact with a normal industrial environment.

2) Suitable for ATEX

## Accessories

**Intermediate-position module**  
**DADM-DGC**  
 (order code: Z1, Z2 or Z3)  
 for DGC-KF

**Materials:**  
 Housing: anodised aluminium  
 Stop screw, nut:  
 Galvanised steel

**Clamp, lever:**  
 High-alloy steel  
 Free of copper and PTFE

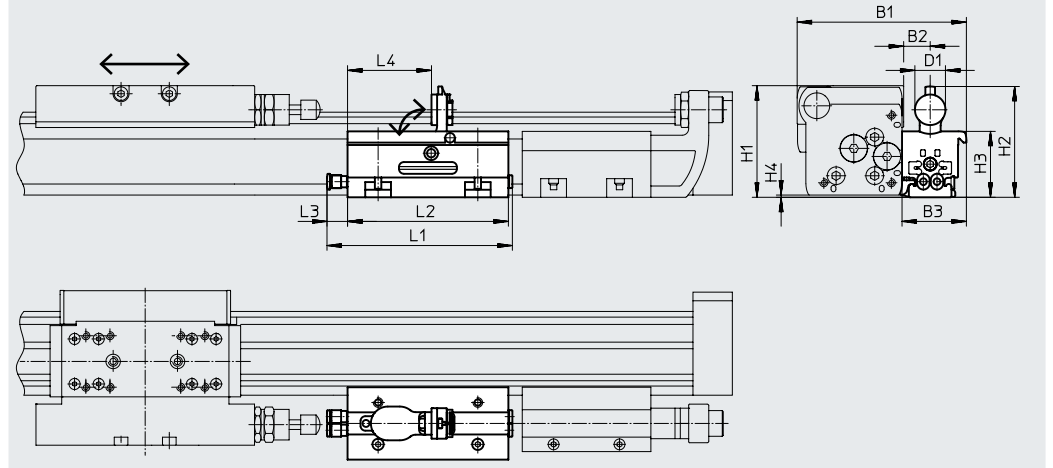

### Dimensions

For diam. [mm]	B1	B2	B3	D1	H1	H2	H3	H4	L1	L2	L3	L4
25	105	16.5	40	19	69.4	68.6	41	1.4	116	100	13.4	52.2
32	117.5	16.5	40	19	80.2	79.7	52	1.7	116	100	13.4	52.2
40	137.5	16	41	27	101.6	101.1	63	2.1	186	170	13.4	76.5

### Minimum distance

Between end stop and intermediate position

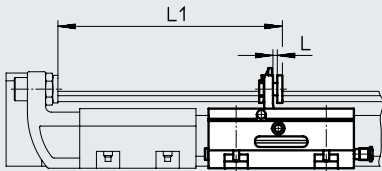

For diam. [mm]	L1
25	145.3
32	185.3
40	271.5

Between two intermediate positions

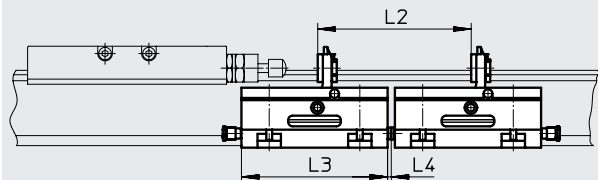

For diam. [mm]	L2	L3	L4
25	105	100	2.5
32	105	100	2.5
40	175	170	2.5

### Note

- Shock absorbers are not included in the scope of delivery. Existing shock absorbers can be removed from the end caps of the linear drive and installed in the shock absorber retainer.
- Under no circumstances may the linear drive and the intermediate-position module be operated without a shock absorber.
- A shock absorber retainer DADP-DGC and a stop KYC are additionally required when using an intermediate-position module.

- The projection (dimension H4) must be observed when using the drive in combination with the intermediate-position module DADM-DGC. Mounting via foot mountings HP or profile mountings MUC is recommended in this case.
- The stop lever positions can be sensed via proximity sensors SME/SMT-10 → page 75.
- After reaching the intermediate position, the slide cannot directly travel further in the same direction. After an intermediate stop, the slide must first move back so that the stop lever of the intermediate-position module can swing in. The intermediate position can then be travelled through.

## Accessories

### Precision adjustment L

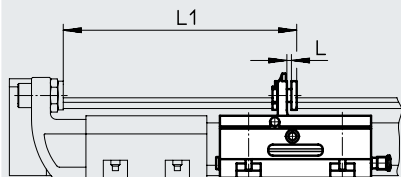

 **Note**

The intermediate-position module DADM-DGC can be used in both directions. A shock absorber retainer DADP-DGC and a stop KYC are additionally needed when using an intermediate-position module.

### Mounting example

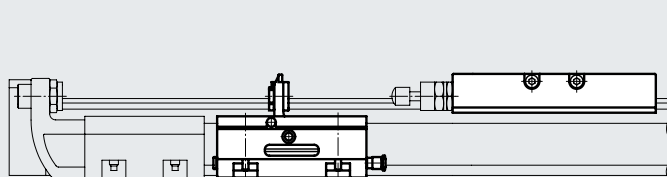

 **Note**

The intermediate-position module DADM-DGC can be mounted at any place along the stroke.

### Technical data

For diam.	[mm]	25	32	40
Pneumatic connection		QS-4		
Operating pressure	[bar]	2.5 ... 8		
Mounting position		Any		
Impact speed	[m/s]	→ page 46		
Swivel time	[ms]	≤100	≤100	≤300
Precision adjustment L	[mm]	2	2	4
Repetition accuracy	[mm]	0.02		
Position sensing		Via proximity sensors SME/SMT-10		
Weight	[g]	430	530	970
Ambient temperature	[°C]	-10 ... +60		
Corrosion resistance class CRC <sup>1)</sup>		2		
Note on materials		Free of copper and PTFE		
		RoHS-compliant		-



1) Corrosion resistance class CRC 2 to Festo standard FN 940070

Moderate corrosion stress. Indoor applications in which condensation can occur. External visible parts with primarily decorative surface requirements which are in direct contact with a normal industrial environment.

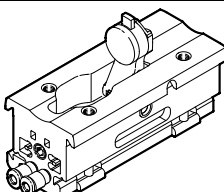
### Ordering data

	For diam. [mm]	Part no.	Type
	25	541700	DADM-DGC-25-A
	32	541701	DADM-DGC-32-A
	40	541702	DADM-DGC-40-A

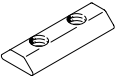
Accessories

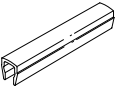
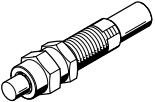
Ordering data		For diam.	Comment	Order code	Part no.	Type	PU <sup>1)</sup>
Slot nut HMBN <sup>2)</sup>		Data sheets → Internet: hmbn					
	25 ... 40	For mounting slot	B	547264	HMBN-5-1M5	10	
	50, 63						186566
Centring pin/sleeve ZBS/ZBH <sup>2)</sup>		Data sheets → Internet: zbs, zbh					
	For DGC-G						
	8, 12	For slide	-	150928	ZBS-5	10	
	8, 12	For cap	-	525273	ZBS-2		
	50, 63			8137184	ZBH-9-B		
	For DGC-GF						
	18	For slide	-	150928	ZBS-5	10	
	25 ... 63			8137184	ZBH-9-B		
	50, 63	For cap	-	8137184	ZBH-9-B		
	For DGC-KF						
	8, 12, 18	For slide	-	150928	ZBS-5	10	
	25 ... 63			8137184	ZBH-9-B		
	8, 12	For cap	-	525273	ZBS-2		
18			150928	ZBS-5			
25 ... 63			8137184	ZBH-9-B			
Slot cover ABP-S <sup>2)</sup>		Data sheets → Internet: abp					
	18 ... 63	For sensor slot Each 0.5 m	L	151680	ABP-5-S	2	
Shock absorber YSRW <sup>2)</sup>		Data sheets → Internet: ysrw					
	8	For DGC basic design and recirculating ball bearing guide	YSRW	540344	YSRW-DGC-8	1	
	12			540345	YSRW-DGC-12		
	18			540346	YSRW-DGC-18-GF		
	25			540348	YSRW-DGC-25-GF		
	32			540350	YSRW-DGC-32-GF		
	40			540352	YSRW-DGC-40-GF		
	50	1232870		YSRW-DGC-40/50-B			
	63	543069		YSRW-DGC-63			
	18	For DGC with recirculating ball bearing guide		540347	YSRW-DGC-18-KF		
	25			540349	YSRW-DGC-25-KF		
	32			540351	YSRW-DGC-32-KF		
	40, 50			1232870	YSRW-DGC-40/50-B		
	63			543069	YSRW-DGC-63		

1) Packaging unit  
2) Suitable for ATEX



## Accessories

Ordering data						
	For diam.	Comment	Order code	Part no.	Type	PU <sup>1)</sup>
One-way flow control valve GRLA <span style="float: right;">Data sheets → Internet: grla</span>						
	8 ... 18	Metal design	-	★ 193137	GRLA-M5-QS-3-D	1
	25, 32			★ 193138	GRLA-M5-QS-4-D	
				★ 193142	GRLA-1/8-QS-3-D	
				★ 193143	GRLA-1/8-QS-4-D	
				★ 193144	GRLA-1/8-QS-6-D	
				★ 193145	GRLA-1/8-QS-8-D	
	40, 50			★ 193146	GRLA-1/4-QS-6-D	
				★ 193147	GRLA-1/4-QS-8-D	
				★ 193148	GRLA-1/4-QS-10-D	
				★ 193149	GRLA-3/8-QS-6-D	
★ 193150		GRLA-3/8-QS-8-D				
63	★ 193151	GRLA-3/8-QS-10-D				



1) Packaging unit

### Proximity sensors for piston diameter 8/12 and intermediate-position module DADM

Ordering data – Proximity sensors for C-slot, magneto-resistive <span style="float: right;">Data sheets → Internet: smt</span>						
	Type of mounting	Switching output	Electrical connection, outlet direction of connection	Cable length [m]	Part no.	Type
<b>N/O contact</b>						
	Insertable in the slot from above	PNP	Plug M8x1, 3-pin, in-line	0.3	★ 551375	SMT-10M-PS-24V-E-0.3-L-M8D
			Cable, 3-wire, in-line	2.5	★ 551373	SMT-10M-PS-24V-E-2.5-L-OE

Ordering data – Proximity sensors for C-slot, magnetic reed <span style="float: right;">Data sheets → Internet: sme</span>						
	Type of mounting	Switching output	Electrical connection, outlet direction of connection	Cable length [m]	Part no.	Type
<b>N/O contact</b>						
	Insertable in the slot from above	Contacting	Plug M8x1, 3-pin, in-line	0.3	★ 551367	SME-10M-DS-24V-E-0.3-L-M8D
			Cable, 3-wire, in-line	2.5	★ 551365	SME-10M-DS-24V-E-2.5-L-OE
			Cable, 2-wire, in-line	2.5	★ 551369	SME-10M-ZS-24V-E-2.5-L-OE
	Insertable in the slot lengthwise	Contacting	Plug M8x1, 3-pin, in-line	0.3	173212	SME-10-SL-LED-24
			Cable, 3-wire, in-line	2.5	173210	SME-10-KL-LED-24

### Proximity sensors for piston diameter 18 ... 63

Ordering data – Proximity sensors for T-slot, magneto-resistive <span style="float: right;">Data sheets → Internet: smt</span>						
	Type of mounting	Switching output	Electrical connection	Cable length [m]	Part no.	Type
<b>N/O contact</b>						
	Insertable in the slot from above, flush with the cylinder profile, short design	PNP	Cable, 3-wire	2.5	★ 574335	SMT-8M-A-PS-24V-E-2.5-OE
			Plug M8x1, 3-pin	0.3	★ 574334	SMT-8M-A-PS-24V-E-0.3-M8D
			Plug M12x1, 3-pin	0.3	★ 574337	SMT-8M-A-PS-24V-E-0.3-M12
		NPN	Cable, 3-wire	2.5	★ 574338	SMT-8M-A-NS-24V-E-2.5-OE
			Plug M8x1, 3-pin	0.3	★ 574339	SMT-8M-A-NS-24V-E-0.3-M8D
<b>N/C contact</b>						
	Insertable in the slot from above, flush with the cylinder profile, short design	PNP	Cable, 3-wire	7.5	★ 574340	SMT-8M-A-PO-24V-E-7.5-OE

Festo core product range





Generally ready for dispatch from the factory within 24 hours  
 Generally ready for dispatch from the factory within 5 days

## Accessories

### Proximity sensors for piston diameter 18 ... 63

Ordering data – Proximity sensors for T-slot, magnetic reed Data sheets → Internet: sme

	Type of mounting	Switching output	Electrical connection	Cable length [m]	Part no.	Type
<b>N/O contact</b>						
	Insertable in the slot from above, flush with the cylinder profile	Contacting	Cable, 3-wire	2.5	★ 543862	SME-8M-DS-24V-K-2.5-OE
				5.0	★ 543863	SME-8M-DS-24V-K-5.0-OE
			Cable, 2-wire	2.5	★ 543872	SME-8M-ZS-24V-K-2.5-OE
			Plug M8x1, 3-pin	0.3	★ 543861	SME-8M-DS-24V-K-0.3-M8D
<b>N/C contact</b>						
	Insertable in the slot from above, flush with the cylinder profile	Contacting	Cable, 3-wire	7.5	★ 546799	SME-8M-DO-24V-K-7.5-OE



Ordering data – Proximity sensor for T-slot, magneto-resistive, for ATEX zone Data sheets → Internet: smt

	Type of mounting	ATEX category		Switching output	Electrical connection	Cable length [m]	Part no.	Type
		Gas	Dust					
<b>N/O contact</b>								
	Insertable in the slot from above, flush with the cylinder profile, short design	II 3G	II 3D	PNP	Plug M8x1, 3-wire	0.3	574342	SMT-8M-A-PS-24V-E-0.3-M8D-EX2

Ordering data – Safety clip for ATEX zone

	Description	For size	Part no.	Type
	<ul style="list-style-type: none"> <li>Protects "equipment that is not intrinsically safe" against simple disconnection, here the plug of the proximity sensor SMT and connecting cable NEBU</li> <li>ATEX category: gas: II 3G / dust: II 3D</li> </ul>	Plug M8x1	548067	NEAU-M8-GD

Ordering data – Connecting cables Data sheets → Internet: nebu

	Electrical connection, left	Electrical connection, right	Cable length [m]	Part no.	Type
	Straight socket, M8x1, 3-pin	Cable, open end, 3-wire	2.5	★ 541333	NEBU-M8G3-K-2.5-LE3
			5	★ 541334	NEBU-M8G3-K-5-LE3
	Straight socket, M12x1, 5-pin	Cable, open end, 3-wire	2.5	★ 541363	NEBU-M12G5-K-2.5-LE3
			5	★ 541364	NEBU-M12G5-K-5-LE3
	Angled socket, M8x1, 3-pin	Cable, open end, 3-wire	2.5	★ 541338	NEBU-M8W3-K-2.5-LE3
			5	★ 541341	NEBU-M8W3-K-5-LE3
	Angled socket, M12x1, 5-pin	Cable, open end, 3-wire	2.5	541367	NEBU-M12W5-K-2.5-LE3
			5	541370	NEBU-M12W5-K-5-LE3

Festo core product range

- ★ Generally ready for dispatch from the factory within 24 hours
- ☆ Generally ready for dispatch from the factory within 5 days