

Semi-rotary drives DSR/DSRL

FESTO



Key features



Brief description

In this semi-rotary drive, the force is transmitted directly to the drive shaft via a vane. The swivel angle is infinitely adjustable from 0 ... 184° (DSRL-10 and 12: 0 ... 181°). The adjustable stop system is separate from the vane, so that the forces are absorbed by the stop blocks. In the end positions, the stops are cushioned with elastic polymer pads.

DSRL-...-FW

The versions with hollow flange shaft can convey liquid or gaseous media, or tubing and electric cables. The force is transmitted directly and without backlash via a multiple-spline shaft.

 **Note**

Engineering software
for calculating inertia
→ www.festo.com

Key features

Mounting options

Without mounting attachments

Direct mounting

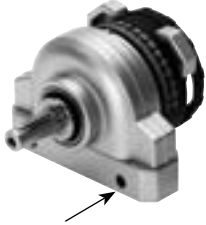

With mounting attachments

For DSR

Foot mounting HSR...-FW



Flange mounting FSR



Push-on flange FWSR



For DSRL

Foot mounting HSR...-FW



Free wheel unit for indexing motion

The free wheel unit is an attachment that is mounted on the drive shaft of the semi-rotary drive DSR. This converts the oscillating rotary motion of the semi-rotary drive into a smooth, synchronous motion. The drive shaft of the semi-rotary drive only moves clockwise or anticlockwise so that it is possible to set infinitely adjustable feed rates.

The minimum possible swivel angle is 0.4° . Switching accuracy is also dependent on switching speed and load.

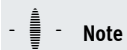

Note

The load must be stopped externally!

FLSR...-L (anticlockwise)
View of the drive shaft side,
anti-clockwise rotation.

FLSR...-R (clockwise)
View of the drive shaft side, clockwise
rotation

Accessories for regulating speed:
One-way flow control valve
→ page 20



Sample applications with hollow flanged shaft in DSRL

Blow out

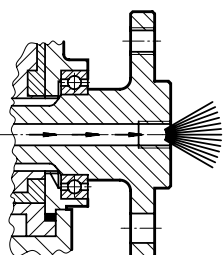

Vacuum

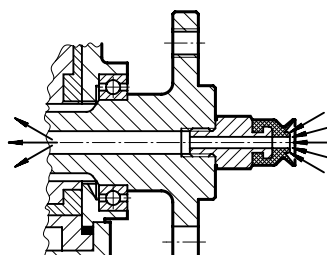

Peripherals overview and type codes

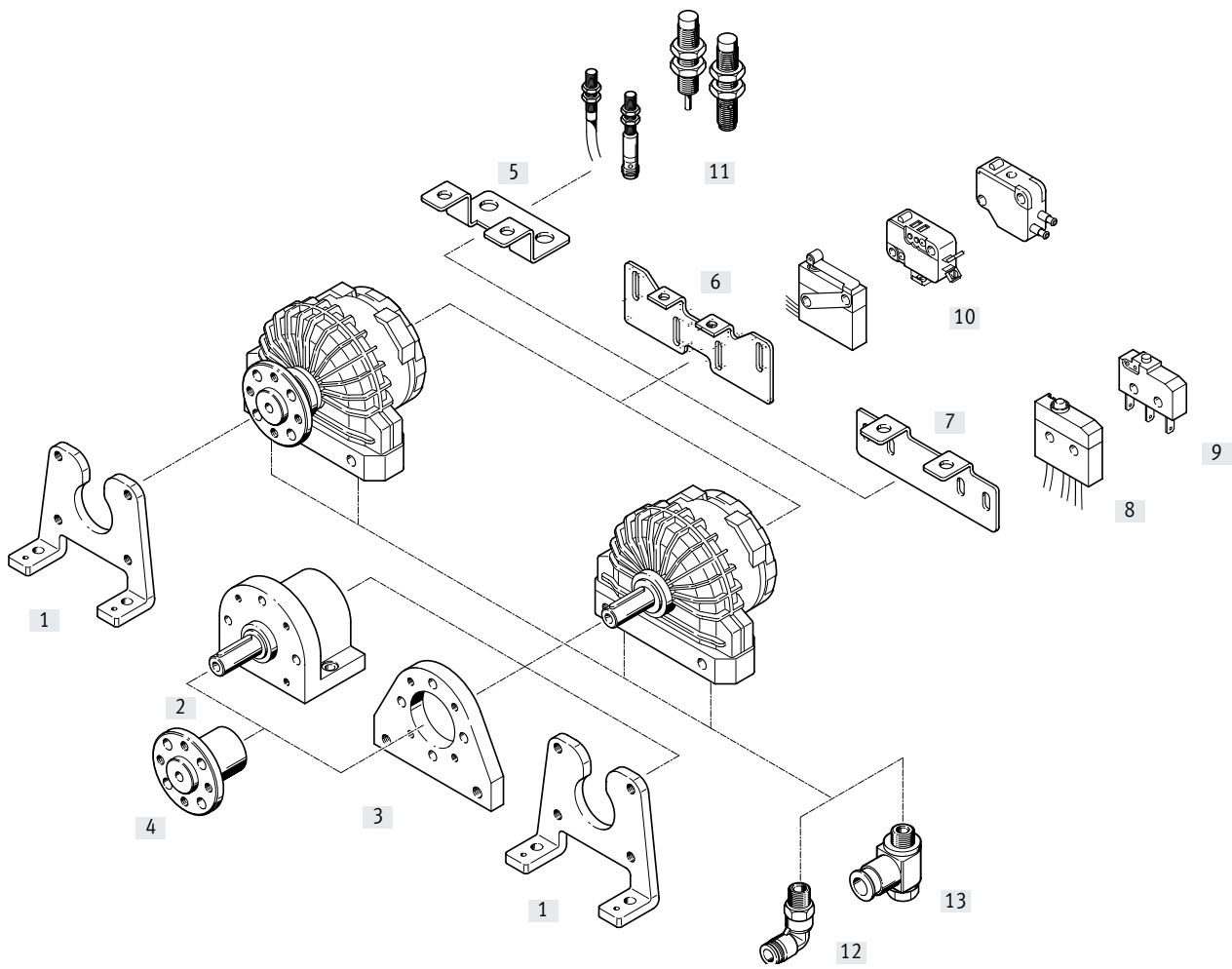

Peripherals overview and type codes

Mounting components and accessories		Description	DSR	DSRL	→ Page/Internet
[1]	Foot mounting HSR-...-FW	On the output side	■	■	12
[2]	Free wheel unit FLSR-...-L/R	For spigot shaft, either clockwise or anticlockwise rotation	■	-	14
[3]	Flange mounting FSR	On the output side	■	-	12
[4]	Push-on flange FWSR	For spigot shaft	■	-	13
[5]	Mounting kit WSR-...	For proximity switch SIEN	■	■	16
[6]	Mounting kit WSR-12 ... 40	For micro stem actuated valve SO-3-PK-3-B, S-3-PK-3-B	■	■	16
[7]	Mounting kit WSR-10/12-K	For microswitch S-3-BE-SW, S-3-BE	■	■	16
[8]	Microswitch S-3-BE-SW	Electric, with cable, splash-proof	■	■	18
[9]	Microswitch S-3-BE	Electric, with push-in connector	■	■	18
[10]	Micro stem actuated valve SO-3-PK-3-B, S-3-PK-3-B	Pneumatic, option of normally open or normally closed	■	■	19
[11]	Proximity switch SIEN	Inductive	■	■	20
[12]	Push-in fitting QSL	For connecting tubing with standard O.D.	■	■	qs
[13]	One-way flow control valve GRLA	For regulating speed	■	■	20

Type codes

001	Series
DSRL	Semi-rotary drive
DSR	Semi-rotary drive

002	Size
10	10
12	12
16	16
25	25
32	32
40	40

003	Nominal swivel angle [°]
180	180

004	Cushioning
P	Elastic cushioning rings/plates on both sides

005	Shaft
	Spigot shaft
FW	Flanged shaft

Data sheet

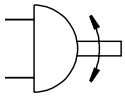

- Diameter
10 ... 40 mm
- Force
0.5 ... 20 Nm

Variants

- With spigot shaft
- With hollow flange shaft

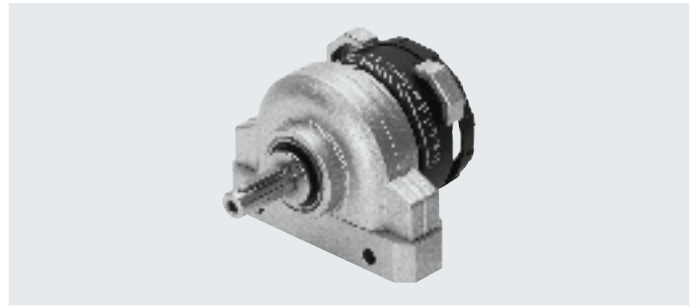

General technical data						
Piston \varnothing	10	12	16	25	32	40
Pneumatic connection	M3	M5	M5	M5	G1/8	G1/4
Design	Rotary cylinder with vane					
Cushioning	Non-adjustable at both ends					
Position sensing	Electrical					
	Pneumatic					
	Inductive					
Type of mounting	With through-hole					
	Via accessories					
Mounting position	Optional					
Max. swivel angle	0 ... 181 °		0 ... 184 °			

† Note: This product conforms to ISO 1179-1 and ISO 228-1.

Operating and environmental conditions						
Piston \varnothing	10	12	16	25	32	40
Operating medium	Compressed air to ISO 8573-1:2010 [7:-:-]					
Operating pressure ¹⁾	[bar]	2.5 ... 8	2 ... 8	1.5 ... 8		
Temperature range ²⁾	[°C]	-10 ... +60				

- 1) The minimum operating pressure can be increased by up to 0.5 bar after a rest period of 24 h
- 2) Note operating range of proximity switches

Forces and torques						
Piston \varnothing	10	12	16	25	32	40
Torque at 6 bar	[Nm]	0.5	1	2	5	20
Max. swivel frequency ¹⁾	[Hz]	3				
Max. permissible radial load ²⁾	[N]	30	45	75	120	350
Max. permissible axial load ²⁾	[N]	10	18	30	50	120
Max. permissible mass moment of inertia ²⁾		Graphs → page 8				

- 1) Please observe the max. permissible mass moments of inertia → page 8
- 2) On the drive shaft at maximum frequency

Data sheet

Materials

Sectional view

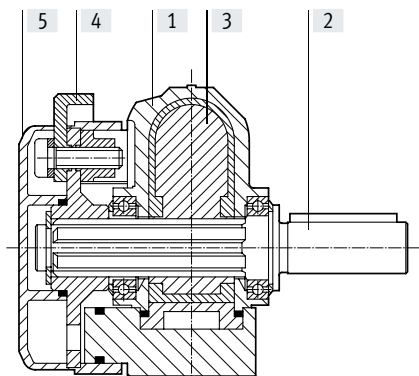

Semi-rotary drive

[1]	Housing	Die-cast zinc
[2]	Drive shaft	Nickel-plated steel
[3]	Rotary vane	Polymer
[4]	Trip cam	Nickel-plated sintered steel
[5]	Cover cap	Polymer
-	Seals	Nitrile rubber

Weight [g]

Piston \varnothing	10	12	16	25	32	40
DSR-...-P	100	200	310	540	1285	2400
DSRL-...-PW	140	240	350	610	1390	2700

Data sheet

Max. permissible mass moment of inertia

Mass moment of inertia m as a function of swivel time S and swivel angle

DSR/DSRL-10

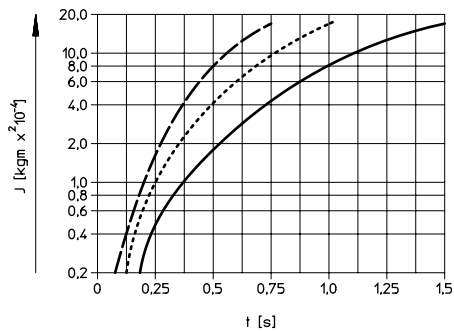

DSR/DSRL-12

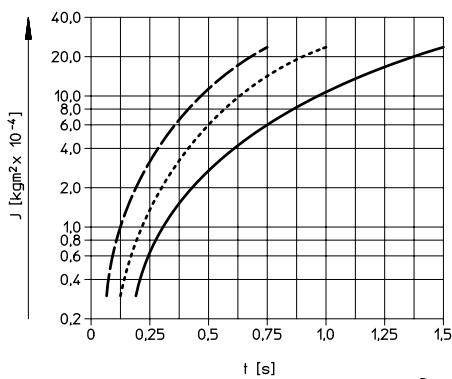

DSR/DSRL-16

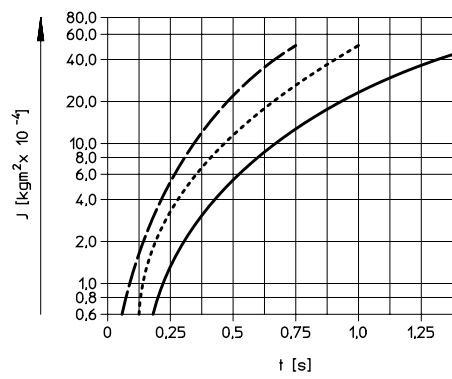

DSR/DSRL-25

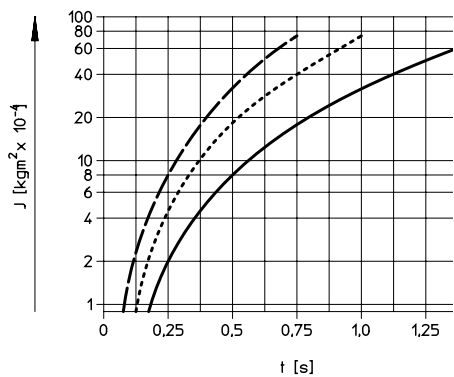

DSR/DSRL-32

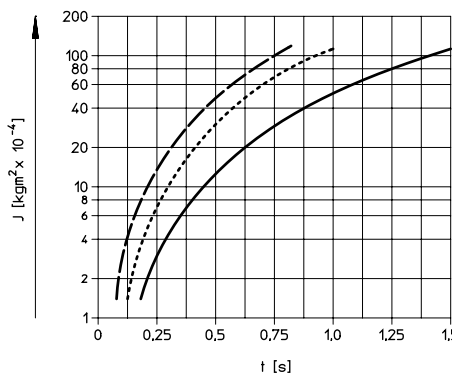

DSR/DSRL-40

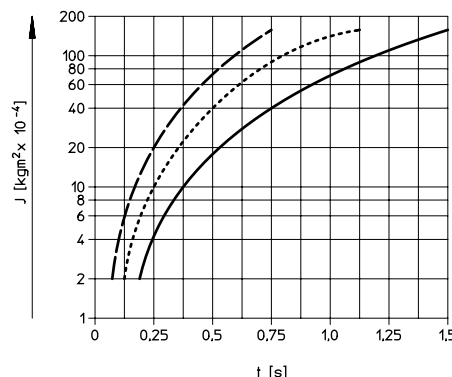

- Swivel angle 90°
- Swivel angle 120°
- - - Swivel angle 180°

Note concerning assembly:

If the specified max. mass moments of inertia are exceeded, external stops must be used. The following must therefore be observed:

The stop must maintain a minimum radius with respect to the drive shaft at all times (r_{\min}). The stop force must not exceed the maximum force. On account of the elastic stops, a precise end position can only be achieved using an external stop.

\varnothing	Stop radius r_{\min}	Force
[mm]	[mm]	[N]
10	13	60
12	15	90
16	17	160
25	21	320
32	28	480
40	40	650

Note

If the semi-rotary drives are restricted to a swivel speed of less than 180°/s, the drives must be operated with a minimum of 6 bar. In this case, a variation of 30% from the constant speed must be taken into account. In order to reduce the variations from the constant speed and obtain the swivel times indicated in the graphs through the use of flow control valves.

Data sheet

Dimensions

Download CAD data → www.festo.com

DSR

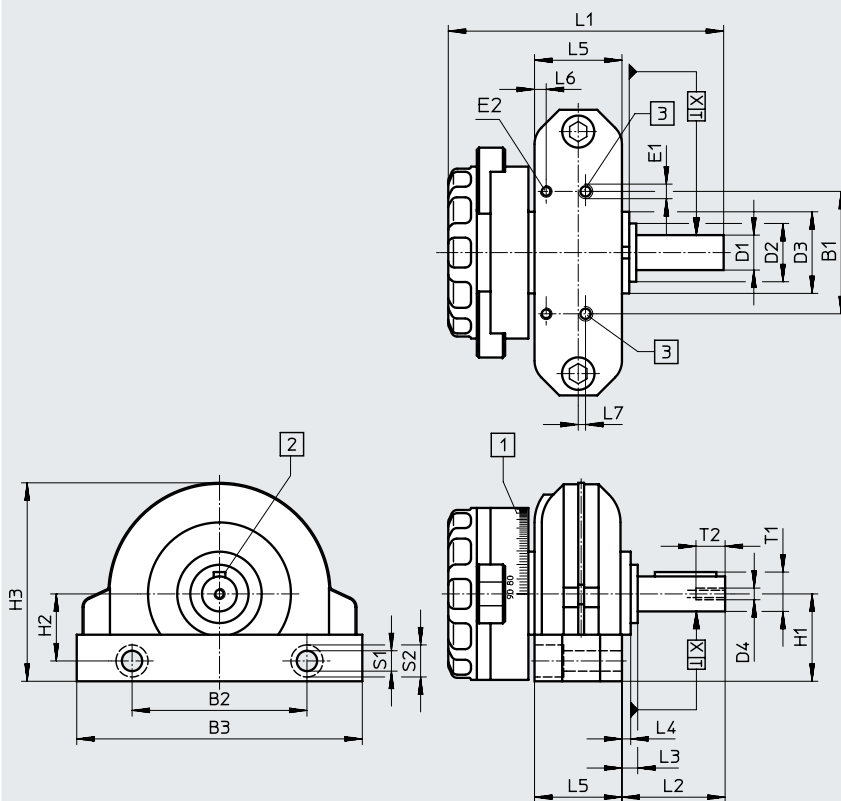

- [1] Angle scale for reading the swivel angle
 [2] Featherkey position at 0°
 [3] Supply port

 **Note**

The swivel angle is 180° and is pressure-dependent.
 The maximum cushioning angle on each side is approx. 1.6° at 8 bar.
 If, at the end of the swivelling motion, the kinetic energy is absorbed by the cushioning, the drive shaft will swivel back by a corresponding proportion of the angle.
 The stops must not be removed, as the vane itself is not designed for setting the end position. An angle scale is provided on the cover cap to help set the swivel angles.
 When attaching additional components to the drive shaft, the maximum permissible tightening torque of the bolt at D4 must not be exceeded.

∅	B1	B2	B3	D1 ∅ g7	D2 ∅	D3 ∅ h8	D4	E1	E2	H1	H2	H3	L1	L2
10	22	32	53	6	12	20	M2.5	M3	M3	19.4	15.5	38.8	57	22.4
12	26	40	65	8	16	22	M3	M5	M3	23.5	18.5	48	65.6	25.5
16	30	46	78	10	17	24	M3	M5	M3	27	20.5	56.5	75.8	29
25	42	60	98	12	18	28	M4	M5	M4	30	23	68.1	94.5	35.4
32	54	80	130	16	27	42	M5	G1/8	M4	43	34	92	125.5	50
40	70	100	160	20	36	52	M6	G1/4	M4	53	40	121	162	60

∅	L3	L4	L5	L6	L7	S1	S2	T1	T2	X	Featherkey to DIN 6885 ¹⁾	Tightening torque for D4 [Nm]
10	6.5	4.5	15.1	2.2	2	3.4	6	6.8	7	0.35	A2 x 2 x 12	0.7
12	5.5	3.5	18	2.1	2.5	4.4	8	8.8	9	0.35	A2 x 2 x 16	1.2
16	6	3.5	22.5	2.1	–	5.5	10	11.2	9	0.35	A3 x 3 x 18	1.2
25	5.4	3	30	4	–	7	11	13.5	10	0.4	A4 x 4 x 25	5.5
32	10	7	36	4	–	8.5	15	18	12.5	0.45	A5 x 5 x 36	5.5
40	10	6	50	4	–	8.5	15	22.5	16	0.5	A6 x 6 x 45	5.5

1) Included in the scope of delivery

Data sheet

Dimensions

Download CAD data → www.festo.com

DSRL

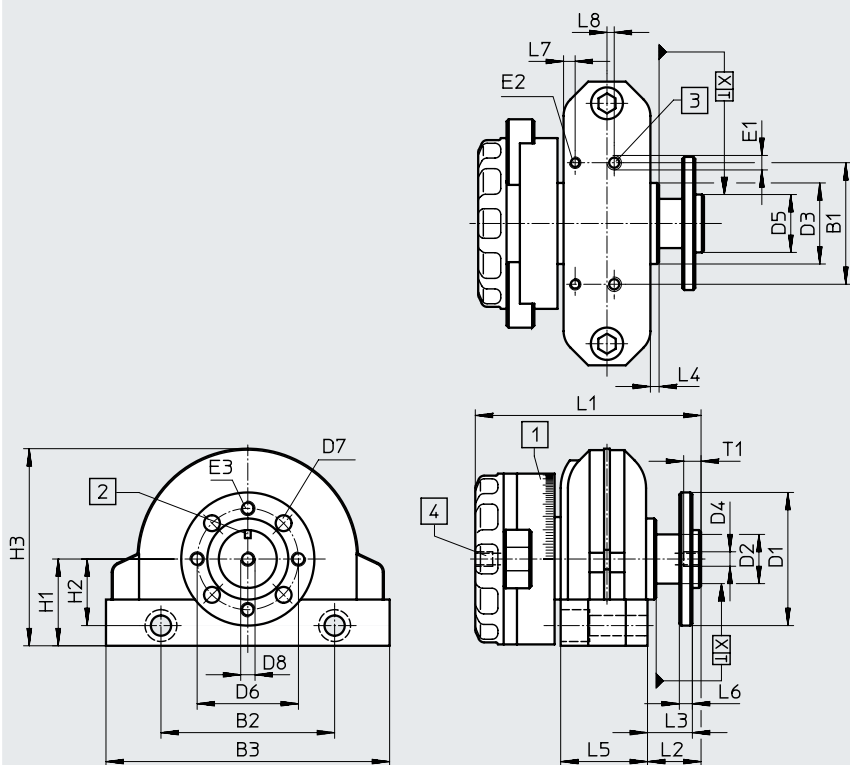

Note

The swivel angle is 180° and is pressure-dependent.
 The maximum cushioning angle on each side is approx. 1.6° at 8 bar.
 If, at the end of the swivelling motion, the kinetic energy is absorbed by the cushioning, the drive shaft will swivel back by a corresponding proportion of the angle.
 The stops must not be removed, as the vane itself is not designed for setting the end position. An angle scale is provided on the cover cap to help set the swivel angles.
 When attaching additional components to the drive shaft, the maximum permissible tightening torque of the bolt at D4 must not be exceeded.

- [1] Angle scale for reading the swivel angle
- [2] Featherkey position at 0°
- [3] Supply port
- [4] Through-hole

∅	B1	B2	B3	D1 ∅	D2 ∅	D3 ∅ h8	D4	D5 ∅ f8	D6 ∅	D7 ∅ H13	D8 ∅ min.	E1	E2	E3	H1
10	22	32	53	30	10	20	M3	11	21	3.4	1.5	M3	M3	M3	19.4
12	26	40	65	33	13	22	M3	14	25	3.4	1.5	M5	M3	M3	23.5
16	30	46	78	38	14	24	M5	16	28	4.5	3.5	M5	M3	M4	27
25	42	60	98	46	17	28	M5	20	35	5.5	3.5	M5	M4	M5	30
32	54	80	130	60	24	42	G1/8	28	45	6.5	7	G1/8	M4	M6	43
40	70	100	160	70	30	52	G1/8	36	54	9	7	G1/4	M4	M8	53

∅	H2	H3	L1	L2	L3	L4	L5	L6	L7	L8	S1	S2	T1	X	Tightening torque for D4 [Nm]
10	15.5	38.8	49	14	12.3	4.5	15.1	3	2.2	2	3.4	6	5	0.35	0.7
12	18.5	48	54.2	13.5	11.5	3.5	18	3	2.1	2.5	4.4	8	5	0.35	1.2
16	20.5	56.5	64.7	16	14	3.5	22.5	4	2.1	-	5.5	10	6	0.35	1.2
25	23	68.1	78	18.5	15.5	3	30	4.5	4	-	7	11	6	0.4	5.5
32	34	92	102.8	26	22	7	36	6	4	-	8.5	15	8	0.45	5.5
40	40	121	134.5	31	26	6	50	7.5	4	-	8.5	15	8	0.5	5.5

Data sheet

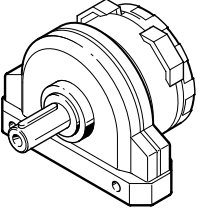
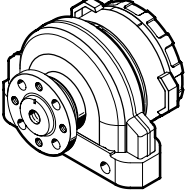
Ordering data		∅ [mm]	Part no.	Type
Semi-rotary drive	Design			
DSR-...-P				
	With spigot shaft	10	33297	DSR-10-180-P
		12	11909	DSR-12-180-P
		16	11910	DSR-16-180-P
		25	11911	DSR-25-180-P
		32	11912	DSR-32-180-P
		40	13467	DSR-40-180-P
DSRL-...-P-FW				
	With hollow flanged shaft	10	33296	DSRL-10-180-P-FW
		12	30654	DSRL-12-180-P-FW
		16	30655	DSRL-16-180-P-FW
		25	30656	DSRL-25-180-P-FW
		32	30657	DSRL-32-180-P-FW
		40	30658	DSRL-40-180-P-FW

Accessories

Foot mounting HSR....-FW

Material:
Steel

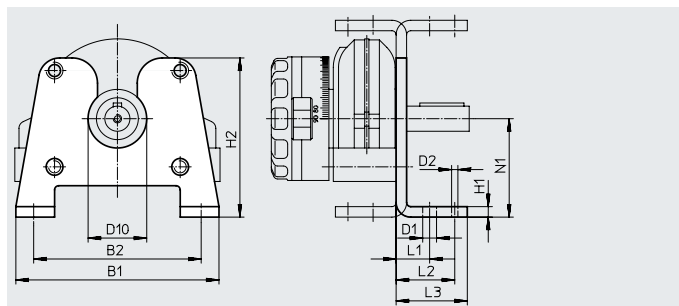

Dimensions and ordering data

For \varnothing [mm]	B1	B2	D1 \varnothing H13	D2	D10	H1	H2	L1	L2	L3	N1	CRC ¹⁾	Weight [g]	Part no.	Type
10	53.5	43	3.5	2	20	4	53	11	17	21	34	2	61	33317	HSR-10-FW
12	64	52	3.5	2	22	4	63	11	17	21	40	2	87	30923	HSR-12-FW
16	77	63	5.7	2	24	5	71	14	22	26.5	44	2	170	30924	HSR-16-FW
25	97	80	6.8	3	28	5	76	16	28	34	47	2	235	30925	HSR-25-FW
32	129	105	8.8	4	42	8	108	20	34	43	66	2	660	30926	HSR-32-FW
40	159	130	8.8	5	52	8	134	25	42	52	81	2	1040	30927	HSR-40-FW

1) Corrosion resistance class CRC 2 to Festo standard FN 940070

Moderate corrosion stress. Indoor applications in which condensation can occur. External visible parts with primarily decorative surface requirements which are in direct contact with a normal industrial environment.

Flange mounting FSR

Material:
Aluminium

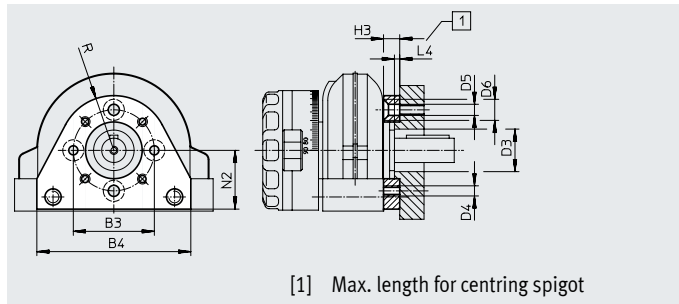

[1] Max. length for centring spigot

Dimensions and ordering data

For \varnothing [mm]	B3	B4	D3 \varnothing min.	D4	D5 \varnothing H13	D6 \varnothing H13	H3	L4 max.	N2	R	CRC ¹⁾	Weight [g]	Part no.	Type
10	28	46	13	M3	3.4	6.5	7	2	20	18	2	22	34480	FSR-10
12	31	54	17	M3	3.4	6.5	7	2	22	20.5	2	32	14658	FSR-12
16	35	62	19	M4	4.5	8.5	8	2	26.5	23.5	2	50	13236	FSR-16
25	40	76	21	M5	5.5	10.4	8	2.5	29	27	2	70	13237	FSR-25
32	56	100	32	M6	6.6	12.4	12	2.5	42	36	2	180	13238	FSR-32
40	72	120	37	M8	9	16.4	14	4	52	46	2	300	14655	FSR-40

1) Corrosion resistance class CRC 2 to Festo standard FN 940070

Moderate corrosion stress. Indoor applications in which condensation can occur. External visible parts with primarily decorative surface requirements which are in direct contact with a normal industrial environment.

Accessories

Push-on flange FWSR

The permissible tightening torque must not be exceeded when attaching the push-on flange FWSR to the drive shaft.

Material:
Anodised wrought aluminium alloy
Free of copper and PTFE

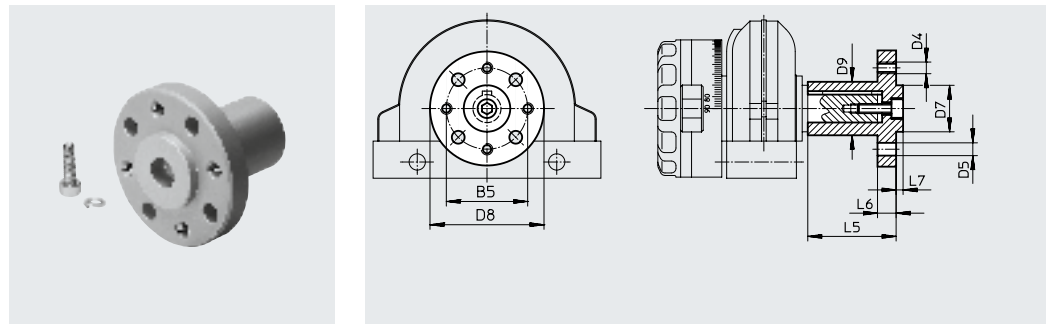

Dimensions and ordering data

For \varnothing [mm]	B5	D4	D5 \varnothing H13	D7 \varnothing f8	D8	D9
10	21	M3	3.4	11	30	12
12	25	M3	3.4	14	35	15
16	28	M4	4.5	16	40	17
25	35	M5	5.5	20	50	23
32	45	M6	6.5	28	60	28
40	54	M8	9	36	70	38

For \varnothing [mm]	L5	L6	L7	Tightening torque [Nm]	CRC ¹⁾	Weight [g]	Part no.	Type
10	22	3	1.6	0.7	2	12	32798	FWSR-10
12	25	3	3	1.2	2	19	14659	FWSR-12
16	28	5	3	1.2	2	30	13239	FWSR-16
25	38	8	3	5.5	2	70	13240	FWSR-25
32	48	10	4	5.5	2	125	13241	FWSR-32
40	60	11	5	5.5	2	240	14656	FWSR-40

1) Corrosion resistance class CRC 2 to Festo standard FN 940070

Moderate corrosion stress. Indoor applications in which condensation can occur. External visible parts with primarily decorative surface requirements which are in direct contact with a normal industrial environment.

Accessories

Free wheel unit FLSR

Material:
 Housing: Cast aluminium
 Sleeve, shaft: Case-hardened steel
 Seal, cap: Nitrile rubber

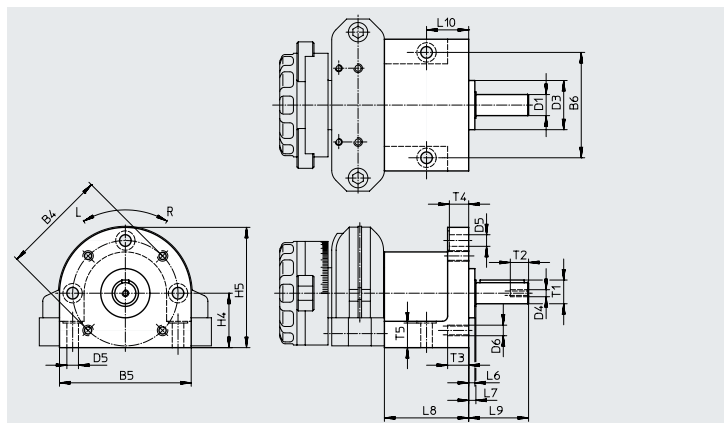

General technical data		10	12	16	25	32	40
Piston ø		10	12	16	25	32	40
Design	Free wheel unit as attachment						
Rotation angle	Infinitely adjustable increment size (independent of rotation angle)						
Applied radial load	[N]	52	77	160	350	200	350
Applied axial load	[N]	30	50	100	200	75	120
Max. torque	[Nm]	0.7	1.3	2.7	6.6	13.3	26.7
Frequency	3 Hz (The load must be stopped externally!)						
Temperature range	[°C]	-10 ... +60					

Direction of rotation

The free wheel unit only allows movement in one of the two possible swivel directions of the semi-rotary drive DSR. The reverse direction is blocked.

FLSR....-R, right-hand (clockwise) rotation

FLSR....-L, left-hand (anticlockwise) rotation

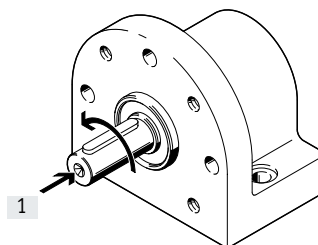
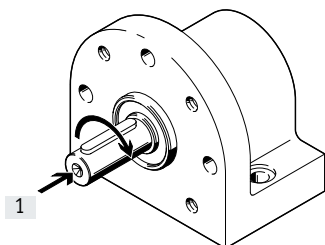

[1] View towards drive shaft

Accessories

Dimensions and ordering data

For \varnothing [mm]	B4	B5	B6	D1 \varnothing g7	D3 \varnothing h8	D4	D5 \varnothing H13	D6	H4	H5	L6	L7	L8	L9	L10
10	38	45	38.5	6	20	–	3.3	M3	20	42.5	3.5	4.2	41.5	20.2	23
12	42	49	41.5	8	25	M3	3.3	M3	24	48.5	3.5	4.5	47.3	24.5	25
16	50	60	50	10	24	M3	4.5	M4	28	58	3.5	4.4	47	27.4	23.5
25	60	75	60	12	28	M4	6.6	M6	31	68.5	3.5	4.1	48	34	24
32	83	98	83	16	42	M5	6.6	M6	44	93	7.2	8.5	60	48.5	30
40	96	114	96	20	52	M6	8.6	M8	54	111	6	8	75	58	38

For \varnothing [mm]	T1	T2	T3	T4	T5	Featherkey ¹⁾ to DIN 6885	CRC ²⁾	Weight [g]	Direction of rotation	Part no.	Type
10	6.8	8	8	5	8	A2 x 2 x 12	2	165	Anticlockwise	33298	FLSR-10-L
									Clockwise	33299	FLSR-10-R
12	8.8	9	8	5	9	A2 x 2 x 16	2	225	Anticlockwise	30930	FLSR-12-L
									Clockwise	30929	FLSR-12-R
16	11.2	11	10	8	11	A3 x 3 x 18	2	340	Anticlockwise	15281	FLSR-16-L
									Clockwise	15280	FLSR-16-R
25	13.5	14	12	11	14	A4 x 4 x 25	2	500	Anticlockwise	13778	FLSR-25-L
									Clockwise	13730	FLSR-25-R
32	18	16	12	11	16	A5 x 5 x 36	2	1140	Anticlockwise	15688	FLSR-32-L
									Clockwise	15687	FLSR-32-R
40	22.5	21	15	11	21	A6 x 6 x 45	2	1800	Anticlockwise	19037	FLSR-40-L
									Clockwise	19036	FLSR-40-R

1) Included in the scope of delivery.

2) Corrosion resistance class CRC 2 to Festo standard FN 940070

Moderate corrosion stress. Indoor applications in which condensation can occur. External visible parts with primarily decorative surface requirements which are in direct contact with a normal industrial environment.

Accessories

Mounting kit

WSR-1 0/12-K

For microswitch S-3-BE, S-3-BE-SW

Material:

Steel

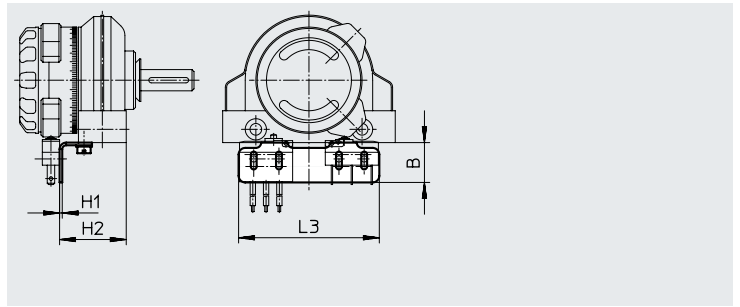

Dimensions and ordering data

For \varnothing	B	H1	H2	L3	CRC ¹⁾	Weight [g]	Part no.	Type
[mm]								
10	15	1	22.2	47	2	11	33414	WSR-10-K
12	15	1	25.1	53	2	13	15686	WSR-12-K

1) Corrosion resistance class CRC 2 to Festo standard FN 940070

Moderate corrosion stress. Indoor applications in which condensation can occur. External visible parts with primarily decorative surface requirements which are in direct contact with a normal industrial environment.

Mounting kit

WSR-12 ... 40

For micro stem actuated valve

S-3-PK-3-B, SO-3-PK-3-B

Material:

Steel

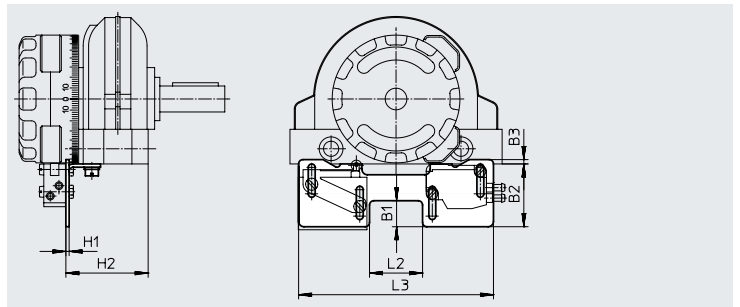

Dimensions and ordering data

For \varnothing	B1	B2	B3	H1	H2	L2	L3	CRC ¹⁾	Weight [g]	Part no.	Type
[mm]											
12	5.8	23.4	4	1.5	23	14	79	2	12	15684	WSR-12
16	10	26.5	4.5	1.5	29.8	19	84.5	2	23	14874	WSR-16
25	12	29	2	1.5	38	24.5	90	2	26	14796	WSR-25
32	12	29	2	1.5	49.2	40.5	107	2	29	14960	WSR-32
40	12	29	2	1.5	68.7	52	118.5	2	32	14961	WSR-40

1) Corrosion resistance class CRC 2 to Festo standard FN 940070

Moderate corrosion stress. Indoor applications in which condensation can occur. External visible parts with primarily decorative surface requirements which are in direct contact with a normal industrial environment.

Accessories

Mounting kit

WSR-...-J

for proximity switch SIEN-M8

WSR-...-J-M5

for proximity switch SIEN-M5

Material:

Steel

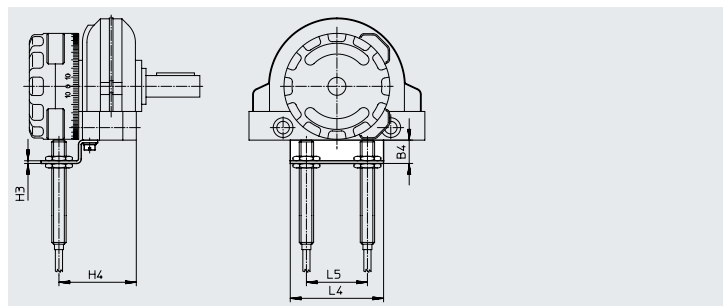

Dimensions and ordering data

WSR-...-J

For \varnothing [mm]	B4	H3	H4	L4	L5	CRC ¹⁾	Weight [g]	Part no.	Type
16	13	1.5	35	52	27	2	12	14873	WSR-16-J
25	13	1.5	43.1	52	34	2	17	14799	WSR-25-J
32	13	1.5	54.3	64	48	2	18	14962	WSR-32-J
40	13	1.5	76.3	80	60	2	24	14963	WSR-40-J

WSR-...-J-M5

For \varnothing [mm]	B4	H3	H4	L4	L5	CRC ¹⁾	Weight [g]	Part no.	Type
10	8	1	25.4	30	20	2	6	33413	WSR-10-J-M5
12	8	1	28.3	34	24.5	2	10	15685	WSR-12-J-M5
16	8	1	34.9	38	27	2	78	15931	WSR-16-J-M5
25	13	1.5	43	52	34	2	17	15932	WSR-25-J-M5
32	13	1.5	54.3	64	48	2	25	15933	WSR-32-J-M5
40	13	1.5	76.3	80	60	2	30	15934	WSR-40-J-M5

1) Corrosion resistance class CRC 2 to Festo standard FN 940070

Moderate corrosion stress. Indoor applications in which condensation can occur. External visible parts with primarily decorative surface requirements which are in direct contact with a normal industrial environment.

Accessories

Electric limit valves for end-position sensing

Microswitch

S-3-BE

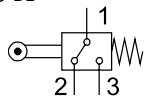

Test mark: VDE-ÜG, UL, CSA, SEMKO

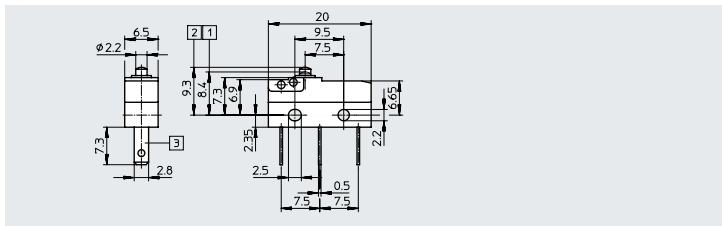
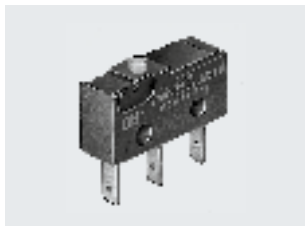

Micro switch with cable
(splash-proof)

S-3-BE-SW

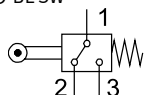

Test mark: VDE, SEV, SEMKO, BEAB

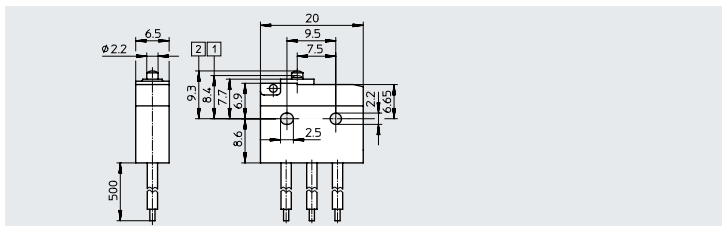

Technical data	S-3-BE	S-3-BE-SW
Design	Changeover switch	
Connection	3 push-in connectors (2.8x0.5 mm)	3 connector leads (0.75 mm ²)
Operating voltage	250 V AC/250 V DC	
Utilisation category	AC 12/DC 12 (ohmic load) AC 14/DC 13 (inductive load)	
CE marking (see declaration of conformity)	To EU Low Voltage Directive	
Degree of protection to EN 60529	IP40	IP67
Temperature range	-20 ... +85°C	
Material	Housing and cover: Black polymer	
Weight	2 g	16 g

S-3-BE, S-3-BE-SW

Alternating voltage		
Voltage [V] ~	Resistance load [A]	Inductive load [A]
12	6	6
24	3	2
60	1	0.5
110	0.5	0.2
220	0.25	0.1

- **Note**

With these electric limit switches, the switching point must not be exceeded by more than 0.5 mm. Actuation only vertical to stem axis.

Ordering data

For ø [mm]	Description	Part no.	Type
10 ... 12	Standard	30648	S-3-BE
	Splash-proof design	30649	S-3-BE-SW

Accessories

Pneumatic limit valves for end-position sensing

Micro stem actuated valve

S-3-PK-3-B

SO-3-PK-3-B

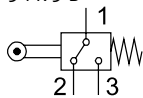

Technical data

Connection	Barbed fitting for 3 mm nominal plastic tubing
Nominal width	1.8 mm
Standard nominal flow rate (1 > 2)	60 l/min
Pressure range	-0.95 ... +8 bar
Actuating force at 6 bar	6 N
Temperature range	-10 ... +60°C
Materials	Polymer, brass
Weight	7 g

Note



The switching point is pressure-dependent and varies up to 0.8 mm in a pressure range from 0 ... 8 bar. The switching point must not be exceeded by more than 0.5 mm. The valve must not be used as a fixed stop and should only be actuated in the direction of the plunger.

Ordering data

For \varnothing [mm]	Description	Part no.	Type
16 ... 40	Normally closed	7843	S-3-PK-3-B
	Normally open	10403	SO-3-PK-3-B

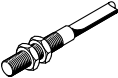
Accessories

Ordering data – Proximity switches, inductive					Data sheets → Internet: sien
	For ø	Comment	Connection	Part no.	Type
	10 ... 40	For mounting kit WSR...-J-M5	Cable	150370	SIEN-M5B-PS-K-L
			Plug	150371	SIEN-M5B-PS-S-L
	16 ... 40	For mounting kit WSR...-J	Cable	150386	SIEN-M8B-PS-K-L
			Plug	150387	SIEN-M8B-PS-S-L

Ordering data – Connecting cables					Data sheets → Internet: nebu
	Electrical connection, left	Electrical connection, right	Cable length [m]	Part no.	Type
	Straight socket, M8x1, 3-pin	Cable, open end, 3-wire	2.5	541333	NEBU-M8G3-K-2.5-LE3
			5	541334	NEBU-M8G3-K-5-LE3
	Angled socket, M8x1, 3-pin	Cable, open end, 3-wire	2.5	541338	NEBU-M8W3-K-2.5-LE3
			5	541341	NEBU-M8W3-K-5-LE3

Ordering data – One-way flow control valves				Data sheets → Internet: grla		
	Connection		Material	Part no.	Type	
	Thread	For tubing O.D.				
	M3	3	Metal design	175041	GRLA-M3-QS-3	
		M5		3	193137	GRLA-M5-QS-3-D
				4	193138	GRLA-M5-QS-4-D
				6	193139	GRLA-M5-QS-6-D
	G1/8	3		193142	GRLA-1/8-QS-3-D	
		4		193143	GRLA-1/8-QS-4-D	
		6		193144	GRLA-1/8-QS-6-D	
		8		193145	GRLA-1/8-QS-8-D	
	G1/4	6		193146	GRLA-1/4-QS-6-D	
		8		193147	GRLA-1/4-QS-8-D	
		10		193148	GRLA-1/4-QS-10-D	