

- > Ø 2 1/2", 4" bore
- > Robust and reliable for long, maintenance free life
- > High positioning speeds
- > Vibration resistant
- > Square, clean line design makes them suitable for hygiene controlled environments

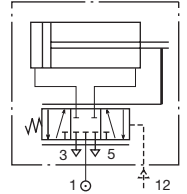

Technical features

Medium:

Compressed air, filtered and lubricated

Installation:

Air supply must incorporate a pre-filter, a high efficiency (5µm) filter and a micro-fog lubricator

Standards:

Tested in accordance with BS4151

Operation:

Double acting, fixed range positioner cylinders

Operating Pressure:

2 ... 10 bar

Control Pressure:

0,2 ... 1 bar

Operating Temperature:

+5°C* ... +80°C

*100% dry air

Sensitiveness:

Within 0,007 bar

Linearity:

Within 1,3% full stroke

Repeatability:

Within 0,75% full stroke

Zero Adjustment:

10% control pressure range

Control Action:

Direct only

Steady state Air Consumption:

Less than 0,35 dm³/s

Stock Strokes:

75, 125, 200 mm

Non-stock Strokes:

Not available

Materials:

Stainless steel piston rod and valve spool, zinc plated steel piston rod end and zero adjuster, brass valve bush, aluminium alloy cylinder barrel, piston and valve body, nitrile rubber seals.

Ordering Information:

To order a 2 1/2" bore fixed range cylinder with 125 mm stroke without mounting brackets quote: M/1525/125.

To order a fixed range cylinder complete with mounting brackets refer to appropriate cylinder mounting table.

Useful Forces

Bar		2	3	4	5	6	7	8	9	10
M/1525 Ø 2 1/2"	F1	349	524	698	873	1047	1222	1396	1571	1745
	F2	349	524	698	873	1047	1222	1396	1571	1745
M/1540 Ø 4"	F1	891	1336	1782	2227	2673	3118	3564	4009	4456
	F2	891	1336	1782	2227	2673	3118	3564	4009	4456

F1 - Force (N) outstroke

F2 - Force (N) instroke

Important: Unlike ordinary double acting cylinders the useful thrust available at the piston rod of a servo-cylinder is not just a function of a piston area, air pressure and efficiency. For sensitive operation, any servo-mechanism of this sort must have a power reserve, which should be approximately equal to the design or required operating effort. For further information, please consult our Technical Service. Where the rate of signal change is very fast the use of flow regulators (see section 4.5) may be required to prevent oscillation. Consult our Technical Service.

Weights of Fixed Range Positioner Cylinders and Mountings (kg)

Model	Weight 75 mm	Weight 125 mm	Weight 200 mm	B	BG	C	D	G	L	R	UF	UR
M/1525	4,5	5,1	5,8	0,25	0,50	0,25	0,25	0,25	1,25	0,80	0,07	0,60
M/1540	9,2	10,2	11,3	1,00	2,00	0,50	1,25	1,00	3,50	2,60	0,07	2,40

Of modern clean-line appearance the M/1540 Fixed Range Positioner Cylinders are completely self-contained and offer an attractive alternative in cases where the full sophistication of the M/1840 universal positioners, see page 1.9.011.01, is not needed in terms of proportional band adjustment, choice of control action and so on.

Of in-line construction, the air connections between positioner valve and the cylinder are integral and the force balance spring is located within the piston rod.

The zero adjustment is designed for easy accessibility and the units are capable of high positioning speeds, whilst their simple and robust construction enables them to give consistent, reliable performance even under conditions of vibration and hostile plant environments, with a long maintenance free life. These characteristics make them suitable for effecting remote, infinite operation of almost any type of damper, quarter turn valve such as a butterfly valve, variable speed gear box, burners, engine governors or throttles in response to either a manual or automatic process control signal in the control pressure range shown above.

The main air supply, in the operating pressure range shown above should be filtered to 5 µm by means of a pre-filter and a high efficiency filter, such as the F13 and F53 models in Section 8 and lubricated. A pressure regulator between the pre-filter and high efficiency filter is recommended.

The M/1525 and M/1540 have been tested in accordance with BS4151 and have a life expectancy of approximately 30,000 cycles. For very high cycle rates consideration should be given to the M/30,000 range of Servo Cylinders.

Basic Fixed Range Positioner Dimension

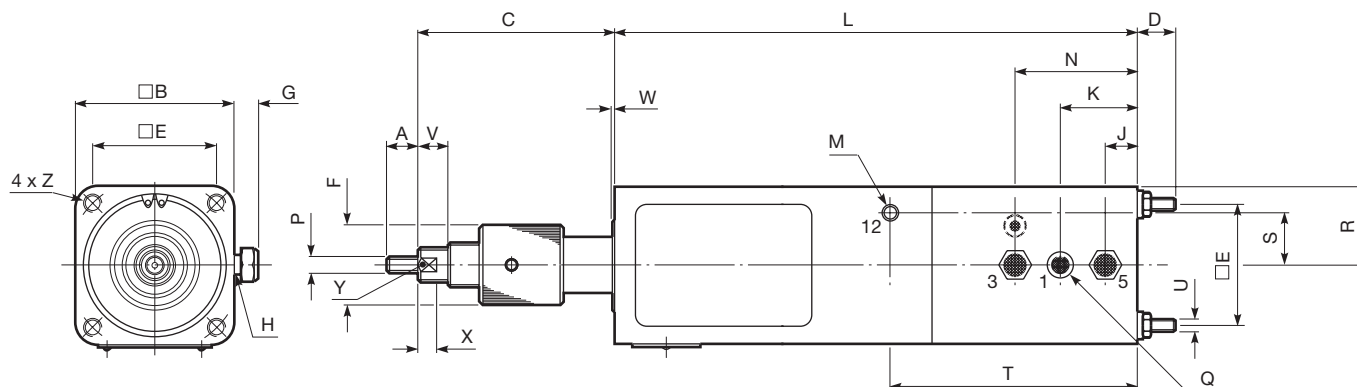

Model	M/1525/75	M/1525/125	M/1525/200	M/1540/75	M/1540/125	M/1540/200
Ø	2 1/2"	2 1/2"	2 1/2"	4"	4"	4"
Stroke	75	125	200	75	125	200
A	15	15	15	15	15	15
B	76,8	76,8	76,8	115	115	115
C	93	93	93	84,4	84,4	84,4
D	17,5	17,5	17,5	30,5	30,5	30,5
E	55,9	55,9	55,9	89	89	89
F	38	38	38	38	38	38
G	11	11	11	15	15	15
H	G1/8x13	G1/8x13	G1/8x13	G1/4x20	G1/4x20	G1/4x20
J	16,5	16,5	16,5	16,5	16,5	16,5
K	38	38	38	37,6	37,6	37,6
L	288	288	413	298,5	348,5	423,5
M	G1/8x8	G1/8x8	G1/8x8	G1/8x8	G1/8x8	G1/8x8
N	59	59	59	59	59	59
P	M10x1,5	M10x1,5	M10x1,5	M10x1,5	M10x1,5	M10x1,5
Q	G1/4	G1/4	G1/4	G1/4	G1/4	G1/4
R	38,4	38,4	38,4	57,5	57,5	57,5
S	23	23	23	34	34	34
T	117,5	117,5	117,5	96,5	96,5	96,5
U	M6x1	M6x1	M6x1	M8x1,25	M8x1,25	M8x1,25
V	15	15	15	15	15	15
W max.	0,36	0,36	0,36	1,1	1,1	1,1
X	8	8	8	8	8	8
Y A/F	17	17	17	17	17	17
Z	M6x1x22	M6x1x22	M6x1x22	M8x1,25x22	M8x1,25x22	M8x1,25x22

For piped exhaust discard exhaust filters fitted to threads 'H'.

Mountings

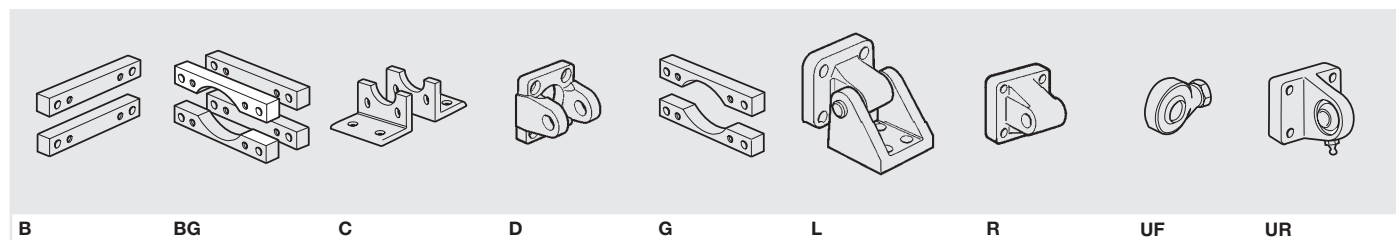

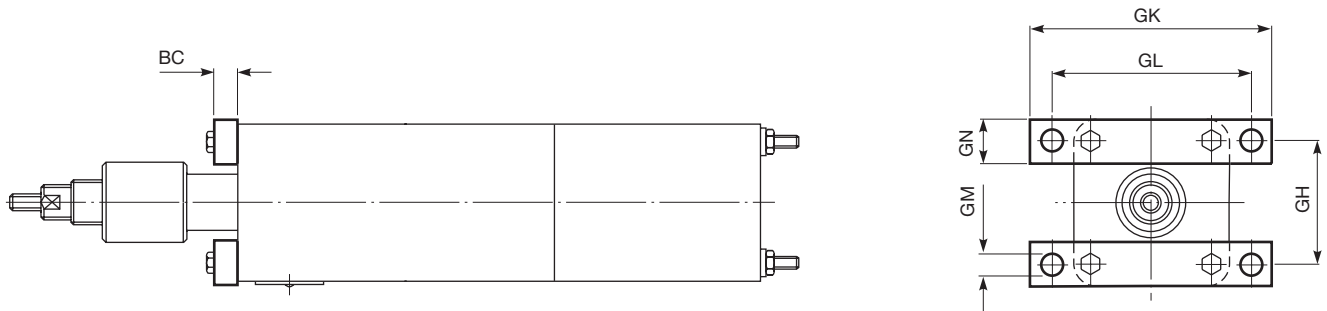
Front Flange Mounting Style 'G'

Model	M/1525/75	M/1525/125	M/1525/200	M/1540/75	M/1540/125	M/1540/200
Reference	QM/1064	QM/1064	QM/1064	QM/1076	QM/1076	QM/1076
BC	10	10	10	16	16	16
GH	55,9	55,9	55,9	89	89	89
GK	113	113	113	178	178	178
GL	93,7	93,7	93,7	146	146	146
GM	8,7	8,7	8,7	13,5	13,5	13,5
GN	20	20	20	32	32	32

To order a Front Flange Mounting Style 'G', quote Reference, e.g. QM/1064 for M/1525.

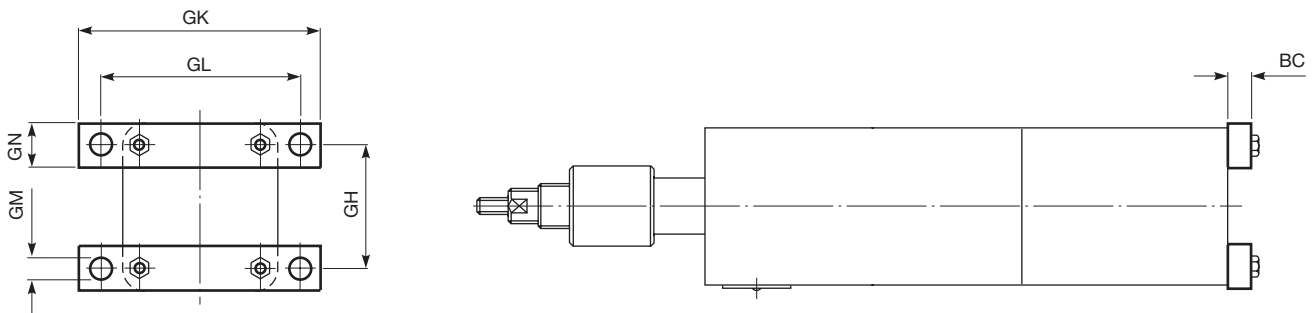
Rear Flange Mounting Style 'B'

Model	M/1525/75	M/1525/125	M/1525/200	M/1540/75	M/1540/125	M/1540/200
Reference	QM/1063	QM/1063	QM/1063	QM/1075	QM/1075	QM/1075
BC	10	10	10	16	16	16
GH	55,9	55,9	55,9	89	89	89
GK	113	113	113	178	178	178
GL	93,7	93,7	93,7	146	146	146
GM	8,7	8,7	8,7	13,5	13,5	13,5
GN	20	20	20	32	32	32

To order a Rear Flange Mounting Style 'B', quote Reference, e.g. QM/1063 for M/1525.

Front and Rear Flange Mounting Style 'BG'

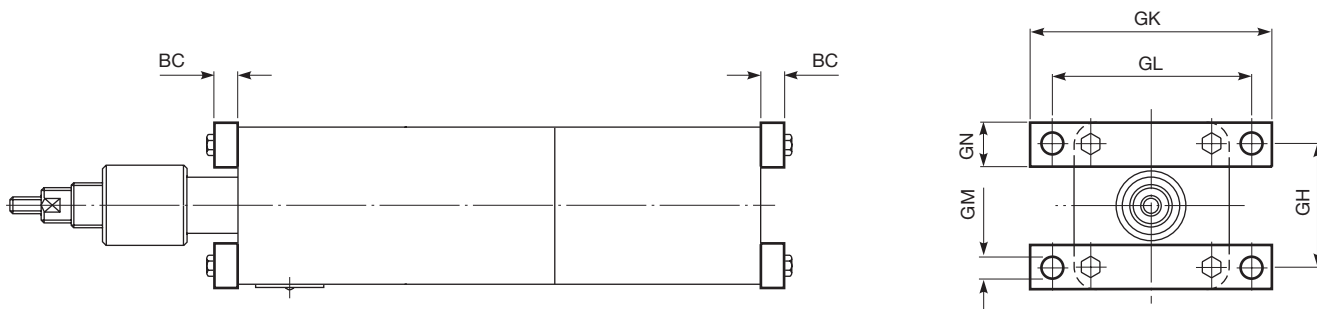

Model	M/1525/75	M/1525/125	M/1525/200	M/1540/75	M/1540/125	M/1540/200
Reference	QM/1065	QM/1065	QM/1065	QM/1077	QM/1077	QM/1077
BC	10	10	10	16	16	16
GH	55,9	55,9	55,9	89	89	89
GK	113	113	113	178	178	178
GL	93,7	93,7	93,7	146	146	146
GM	8,7	8,7	8,7	13,5	13,5	13,5
GN	20	20	20	32	32	32

To order a Front and Rear Flange Mounting Style 'BG', quote Reference, e.g. QM/1077 for M/1540.

Rear Clevis Mounting Style 'D'

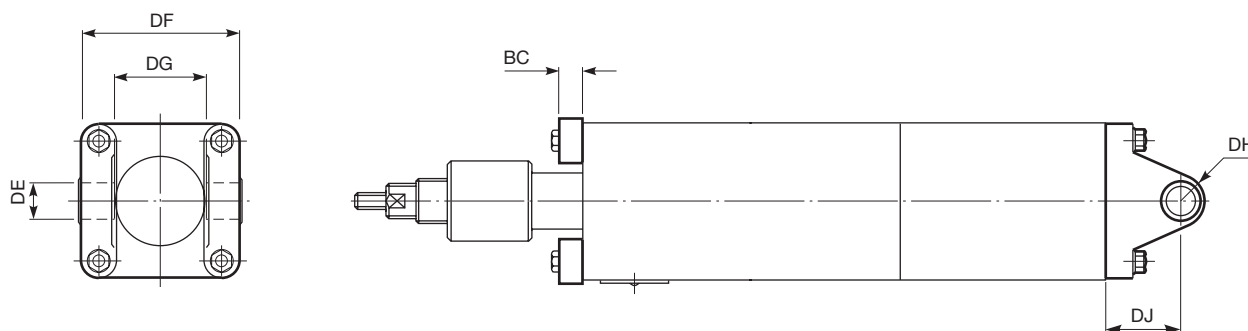

Model	M/1525/75	M/1525/125	M/1525/200	M/1540/75	M/1540/125	M/1540/200
Reference	QM/1067	QM/1067	QM/1067	QM/1079	QM/1079	QM/1079
DE	16,033 16,000	16,033 16,000	16,033 16,000	22,033 22,000	22,033 22,000	22,033 22,000
DF	74	74	74	117,5	117,5	117,5
DG	42,9	42,9	42,9	69,85	69,85	69,85
DH	13	13	13	19	19	19
DJ	28,6	28,6	28,6	57,2	57,2	57,2

To order a Rear Clevis Mounting Style 'D', quote Reference, e.g. QM/1067 for M/1525.

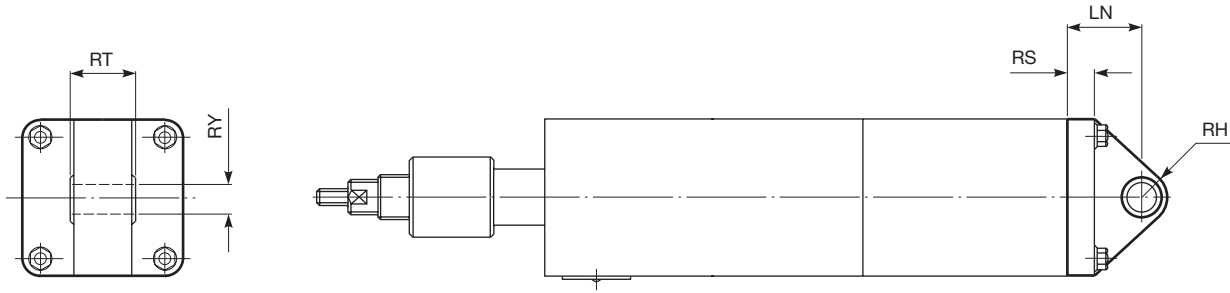
Rear Eye Mounting Style 'R'

Model	M/1525/75	M/1525/125	M/1525/200	M/1540/75	M/1540/125	M/1540/200
Reference	QM/1086	QM/1086	QM/1086	QM/1087	QM/1087	QM/1087
LN	35	35	35	50,8	50,8	50,8
RH	14,5	14,5	14,5	21	21	21
RS	9,5	9,5	9,5	21	21	21
RT	38,1	38,1	38,1	44,5	44,5	44,5
RY	16,049 16,006	16,049 16,006	16,049 16,006	18,049 18,006	18,049 18,006	18,049 18,006

To order a Rear Eye Mounting Style 'R', quote Reference, e.g. QM/1087 for M/1540.

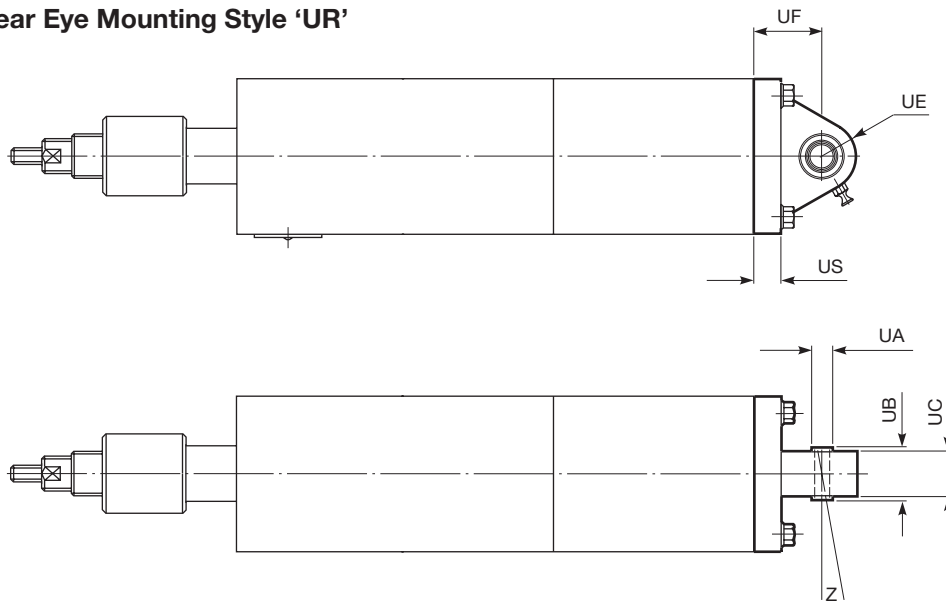
Universal Rear Eye Mounting Style 'UR'

Model	M/1525/75	M/1525/125	M/1525/200	M/1540/75	M/1540/125	M/1540/200
Reference	QM/1074	QM/1074	QM/1074	QM/1085	QM/1085	QM/1085
UA	14,018 14,000	14,018 14,000	14,018 14,000	14,018 14,000	14,018 14,000	14,018 14,000
UB	19	19	19	19	19	19
UC	15	15	15	15	15	15
UE	26	26	26	26	26	26
UF	35	35	35	50,8	50,8	50,8
US	9	9	9	21	21	21
Z	10	10	10	10	10	10

To order a Universal Rear Eye Mounting Style 'UR', quote Reference, e.g. QM/1085 for M/1540.

Foot Mounting Style 'C'

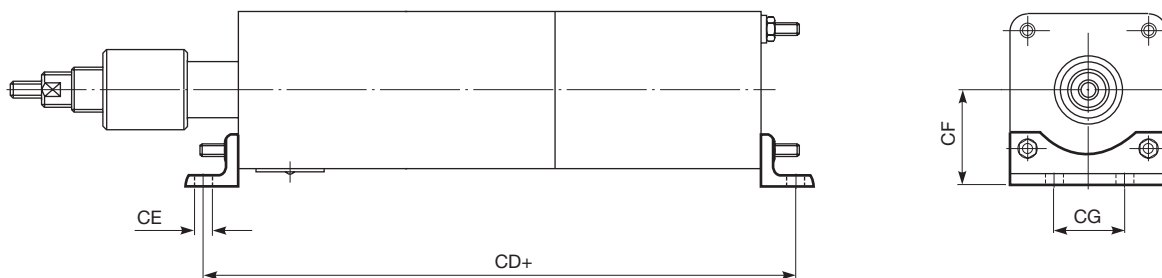

Model	M/1525/75	M/1525/125	M/1525/200	M/1540/75	M/1540/125	M/1540/200
Reference	QM/1066	QM/1066	QM/1066	QM/1078	QM/1078	QM/1078
CD+	351,5	401,5	476,5	349,3	399,3	474,3
CE	8,7	8,7	8,7	13,5	13,5	13,5
CF	47	47	47	70	70	70
CG	55,6	55,6	55,6	50,8	50,8	50,8

To order a Foot Mounting Style 'C', quote Reference, e.g. QM/1066 for M/1525.

Universal Piston Rod Eye Mounting Style 'UF'

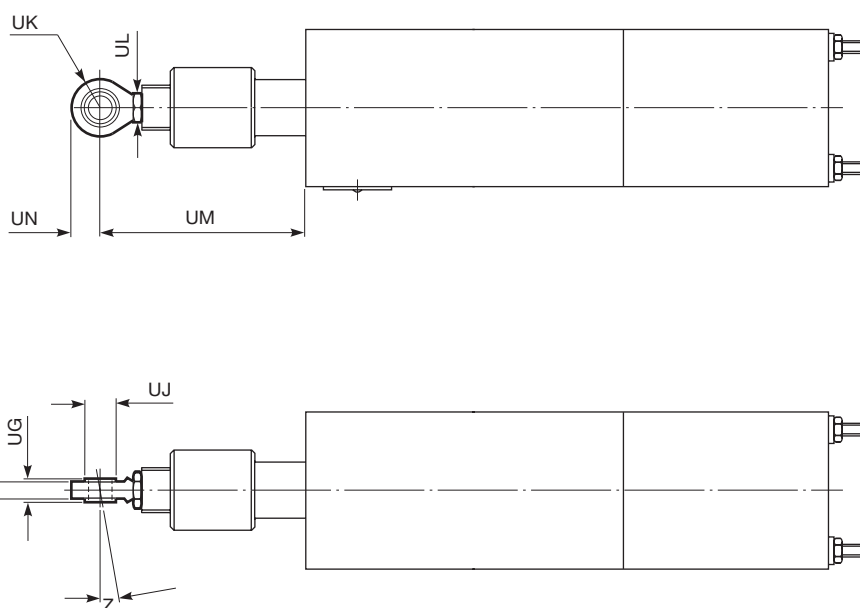

Model	M/1525/75	M/1525/125	M/1525/200	M/1540/75	M/1540/125	M/1540/200
Reference	QM/1073	QM/1073	QM/1073	QM/1073	QM/1073	QM/1073
UG	14	14	14	14	14	14
UH	10,5 10,015	10,5 10,015	10,5 10,015	10,5 10,015	10,5 10,015	10,5 10,015
UJ	10,000	10,000	10,000	10,000	10,000	10,000
UK	15	15	15	15	15	15
UL A/F	17	17	17	17	17	17
UM	120	120	120	111	111	111
UN	10	10	10	10	10	10
Z	10°	10°	10°	10°	10°	10°

To order a Universal Piston Rod Eye Mounting Style 'UF', quote Reference, e.g. QM/1073 for either M/1525 or M/1540.

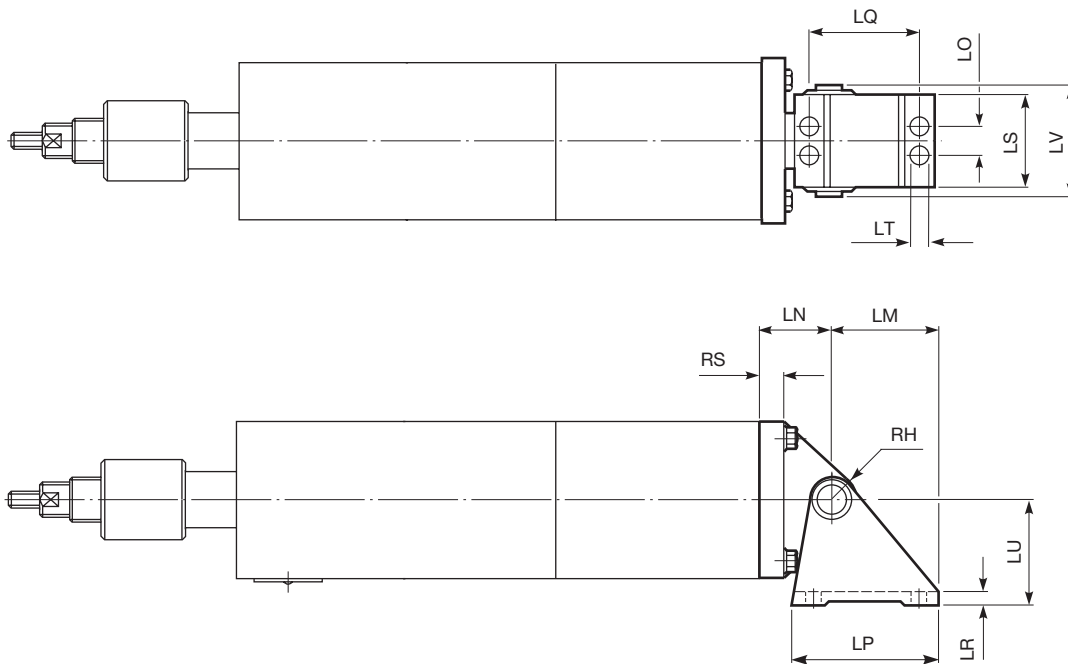
Rear Hinge Mounting Style 'L'

Model	M/1525/75	M/1525/125	M/1525/200	M/1540/75	M/1540/125	M/1540/200
Reference	QM/1069	QM/1069	QM/1069	QM/1084	QM/1084	QM/1078
LM	50,8	50,8	50,8	78	78	78
LN	35	35	35	50,8	50,8	50,8
LP	67	67	67	102	102	102
LQ	47,6	47,6	47,6	76,2	76,2	76,2
LR	8	8	8	9,5	9,5	9,5
LO	19	19	19	22,2	22,2	22,2
LS	68,3	68,3	68,3	70	70	70
LT	8,3	8,3	8,3	11,9	11,9	11,9
LU	47,6	47,6	47,6	74,6	74,6	74,6
LV	73	73	73	82,5	82,5	82,5
RH	14,5	14,5	14,5	21	21	21
RS	9,5	9,5	9,5	21	21	21

To order a Rear Hinge Mounting Style 'L', quote Reference, e.g. QM/1069 for M/1525.

Spares

Model	Barrel	Piston & Piston rod Assembly	Spares kit
M/1525	MP24174*	QM/1525*/29	QM/1525/00
M/1540	MP24176*	QM/1540*/29	QM/1540/00

*Insert stroke length

Warning

These products are intended for use in industrial compressed air systems only. Do not use these products where pressures and temperatures can exceed those listed under

»Technical features/data«.

Before using these products with fluids other than those specified, for non-industrial applications, life-support systems or other applications not within published specifications, consult IMI Precision Engineering.

Through misuse, age, or malfunction, components used in fluid power systems can fail in various modes.

The system designer is warned to consider the failure modes of all component parts used in fluid power systems and to provide adequate safeguards to prevent personal injury or damage to equipment in the event of such failure.

System designers must provide a warning to end users in the system instructional manual if protection against a failure mode cannot be adequately provided.

System designers and end users are cautioned to review specific warnings found in instruction sheets packed and shipped with these products.