

Series	BMF 303	BMF 303	BMF 303
Type	Connector M5×0.5 with rotatable union nut	Connector M8×1 with rotatable union nut	

The universal sensor for position monitoring on small grippers and cylinders. A variety of mounting brackets enables adapting to virtually every miniaturized pneumatic actuator on the market.

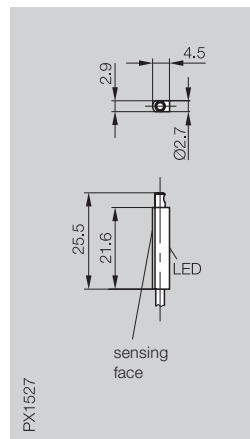
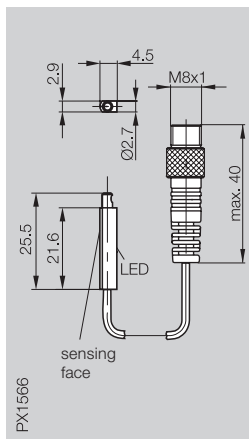
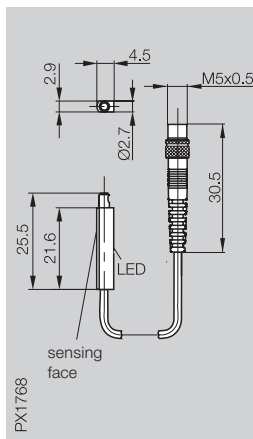

PNP	NO	BMF 303K-PS-C-2A-S26-00,3	BMF 303K-PS-C-2A-SA2-S49-00,3	BMF 303K-PS-C-2A-PU-02
	NC		BMF 303K-PO-C-2A-SA2-S49-00,3	BMF 303K-PO-C-2A-PU-02
NPN	NO	BMF 303K-NS-C-2A-S26-00,3	BMF 303K-NS-C-2A-SA2-S49-00,3	BMF 303K-NS-C-2A-PU-02
	NC		BMF 303K-NO-C-2A-SA2-S49-00,3	BMF 303K-NO-C-2A-PU-02
Rated operating field strength H _n		1.2 kA/m	1.2 kA/m	1.2 kA/m
Assured operating field strength H _a		≥ 2 kA/m	≥ 2 kA/m	≥ 2 kA/m
Hysteresis of H _n		≤ 45 %	≤ 45 %	≤ 45 %
Temperature drift of turn-on point of H _n		≤ 0.3 %/°C	≤ 0.3 %/°C	≤ 0.3 %/°C
Turn-on delay		≤ 0.07 ms	≤ 0.07 ms	≤ 0.07 ms
Turn-off delay		≤ 0.07 ms	≤ 0.07 ms	≤ 0.07 ms
Supply voltage U _B		10...30 V DC	10...30 V DC	10...30 V DC
Voltage drop U _d		≤ 2 V	≤ 2 V	≤ 2 V
Rated insulation voltage U _i		75 V DC	75 V DC	75 V DC
Rated operational current I _b		100 mA	100 mA	100 mA
No-load supply current I ₀ max.		≤ 5 mA	≤ 5 mA	≤ 5 mA
Polarity reversal protected		yes	yes	yes
Short circuit protected		yes	yes	yes
Ambient temperature range T _a		-25...+70 °C	-25...+70 °C	-25...+70 °C
Utilization category		DC 13	DC 13	DC 13
Degree of protection per IEC 60529		IP 67	IP 67	IP 67
Housing material		LCP	LCP	LCP
Connection		0.3 m cable (PUR) with connector	0.3 m cable (PUR) with connector	2 m Cable PUR
No. of wires × cross-section				3×0.10 mm ²
Approval		cULus	cULus	cULus
Recommended connector		BKS- 25	BKS- 48	

Other cable lengths on request.



Wiring diagrams

NO

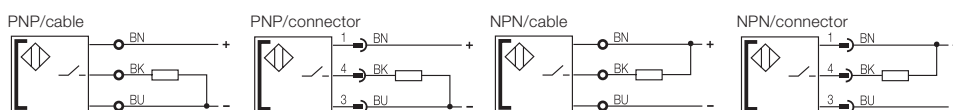

NC

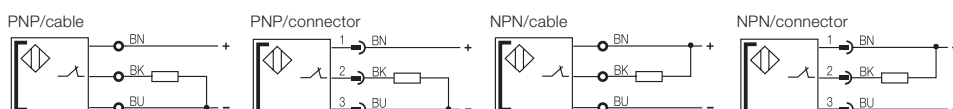

Please order accessories separately see page 5.74

Advantages

Sensor disappears in the slot!



Switchpoint can be adjusted in seconds!
Turn screw one revolution, adjust position, tighten.



Switchpoint cannot be lost. Even if you replace the sensor, the adjusted switchpoint is determined by the mounting bracket, not the sensor.



BMF 303-HW-28/30



BMF 303-HW-33

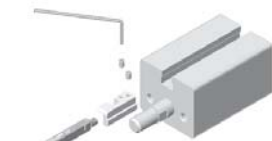















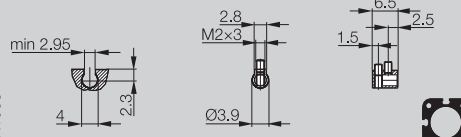



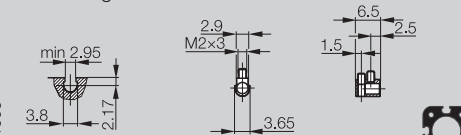



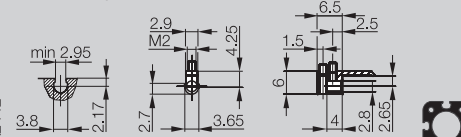



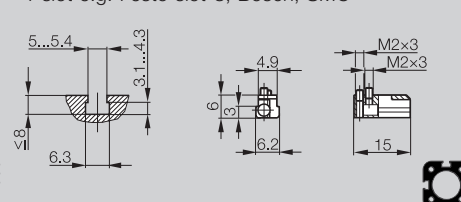



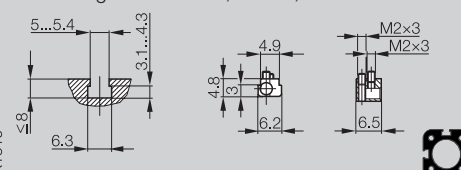



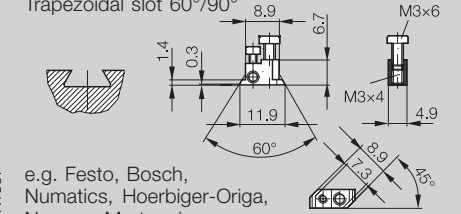

For hose clamp matrix see page 3.0.10.

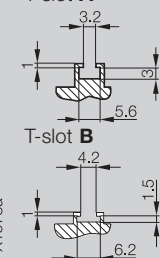
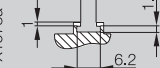
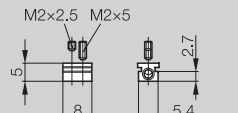
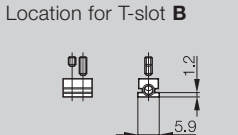
Ordering code

Advantages

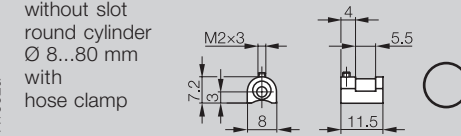
Cylinder type

Mounting brackets

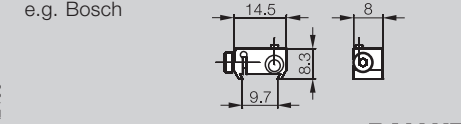
<p>BMF 303-HW-28</p> 	  	<p>C-slot e.g. SMC</p> 
<p>BMF 303-HW-30</p> 	  	<p>C-slot e.g. Festo slot-10</p> 
<p>BMF 303-HW-31</p> 	  	<p>C-slot e.g. Festo</p> 
<p>BMF 303-HW-33</p> 	  	<p>T-slot e.g. Festo slot-8, Bosch, SMC</p> 
<p>BMF 303-HW-40</p> 	  	<p>T-slot e.g. Festo slot-8, Bosch, SMC</p> 
<p>BMF 303-HW-44</p> 	 	<p>Trapezoidal slot 60°/90°</p>  <p>e.g. Festo, Bosch, Numatics, Hoerbiger-Origa, Norgren-Martonair</p>
<p>BMF 303-HW-51</p> 	 	<p>T-slot A</p>  <p>T-slot B</p>  <p>Location for T-slot A</p>  <p>Location for T-slot B</p> 
<p>BMF 303-HW-59</p> 	 	<p>without slot round cylinder Ø 8...80 mm with hose clamp</p> 
<p>BMF 303-HW-80</p> 	 	<p>e.g. Bosch</p> 

Series	BMF 305	BMF 305	BMF 305
Type	Connector M8x1 with rotatable union nut	Connector M12x1 with rotatable union nut	

The all-rounder for position monitoring on cylinders.

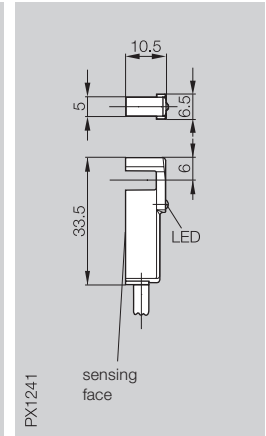
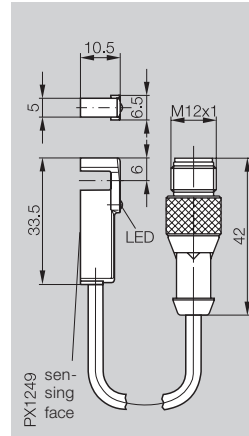
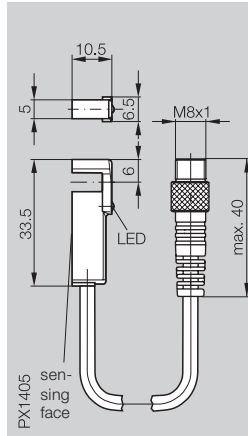

PNP	NO	BMF 305K-PS-C-2-SA2-S49-00,3	BMF 305K-PS-C-2-S4-00,2	BMF 305K-PS-C-2-PU-02
	NC	BMF 305K-PO-C-2-SA2-S49-00,3		BMF 305K-PO-C-2-PU-02
NPN	NO	BMF 305K-NS-C-2-SA2-S49-00,3		BMF 305K-NS-C-2-PU-02
	NC	BMF 305K-NO-C-2-SA2-S49-00,3		BMF 305K-NO-C-2-PU-02

Rated operating field strength H _n	1.2 kA/m	1.2 kA/m	1.2 kA/m
Assured operating field strength H _a	≥ 2 kA/m	≥ 2 kA/m	≥ 2 kA/m
Hysteresis of H _n	≤ 45 %	≤ 45 %	≤ 45 %
Temperature drift of turn-on point of H _n	≤ 0.3 %/°C	≤ 0.3 %/°C	≤ 0.3 %/°C
Turn-on delay	≤ 0.05 ms	≤ 0.05 ms	≤ 0.05 ms
Turn-off delay	≤ 0.05 ms	≤ 0.05 ms	≤ 0.05 ms
Supply voltage U _B	10...30 V DC	10...30 V DC	10...30 V DC
Voltage drop U _d	≤ 3.1 V	≤ 3.1 V	≤ 3.1 V
Rated insulation voltage U _i	75 V DC	75 V DC	75 V DC
Rated operational current I _o	200 mA*	200 mA*	200 mA*
No-load supply current I _o max.	≤ 30 mA	≤ 30 mA	≤ 30 mA
Polarity reversal protected	yes	yes	yes
Short circuit protected	yes	yes	yes
Ambient temperature range T _a	-25...+85 °C	-25...+85 °C	-25...+85 °C
Utilization category	DC 13	DC 13	DC 13
Degree of protection per IEC 60529	IP 67	IP 67	IP 67
Housing material	LCP	LCP	LCP
Connection	0.3 m cable (PUR) with connector	0.2 m cable (PUR) with connector	2 m Cable PUR
No. of wires x cross-section			3x0.14 mm ²
Approval	cULus	cULus	cULus
Recommended connector	BKS- 48	BKS- 19	

*Temperature load curve see page 3.0.6

Other cable lengths on request.



Wiring diagrams

NO

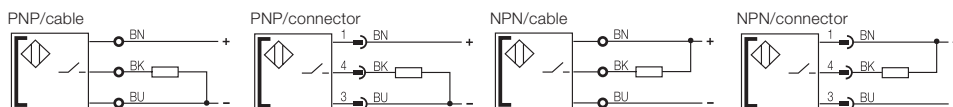

NC

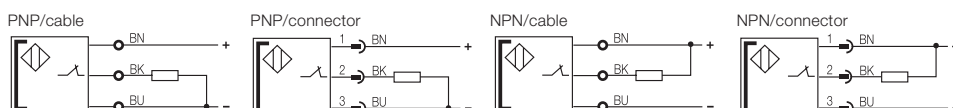

BMF 305	BMF 305	BMF 305	BMF 305
BMF 305M-PS-C-2-S4	BMF 305M-PS-C-2-S49	BMF 305M-PS-C-2-SA4-S49	BMF 305M-PS-W-2-S4
1.2 kA/m ≥ 2 kA/m ≤ 45 % ≤ 0.3 %/°C ≤ 0.05 ms ≤ 0.05 ms 10...30 V DC ≤ 3.1 V 75 V DC 200 mA* ≤ 30 mA yes yes -25...+85 °C DC 13 IP 67 Al Connector	1.2 kA/m ≥ 2 kA/m ≤ 45 % ≤ 0.3 %/°C ≤ 0.05 ms ≤ 0.05 ms 10...30 V DC ≤ 3.1 V 75 V DC 200 mA* ≤ 30 mA yes yes -25...+85 °C DC 13 IP 67 Al Connector	1.2 kA/m ≥ 2 kA/m ≤ 45 % ≤ 3 %/°C ≤ 0.05 ms ≤ 0.05 ms 10...30 V DC ≤ 3.1 V 75 V DC 200 mA* ≤ 30 mA yes yes -25...+105 °C DC 13 IP 65 Al Connector	1.2 kA/m ≥ 2 kA/m ≤ 45 % ≤ 0.3 %/°C ≤ 0.05 ms ≤ 0.05 ms 10...30 V DC ≤ 4 V 75 V DC 200 mA* ≤ 30 mA yes yes -25...+85 °C DC 13 IP 67 Al Connector
cULus BKS- 19/BKS- 20	cULus BKS- 48/BKS- 49	cULus BKS-S146-00	cULus BKS- 19/BKS- 20

The series BMF 305M/315M/32M-...-W-... is suitable for extreme conditions of use. The housings are metal, making them resistant to weld splatter. Conditions including weld currents of over 25 kA do not affect the function ability of the sensor. The output state of the sensor is stored during AC welding.

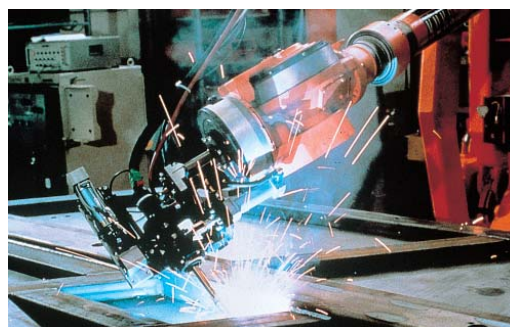

Sensors for Pneumatic Cylinders

Mounting brackets,
selection guide, installation
for BMF 305

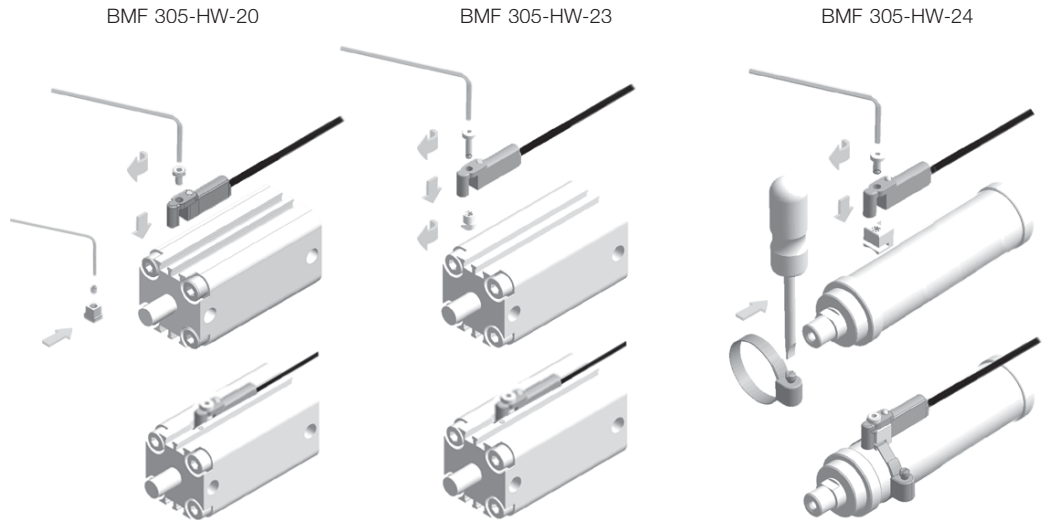

Advantages



Can be inserted in slot from above. Anytime! Also afterwards! Fast! Saves time!



Switchpoint can be adjusted in seconds! Turn screw one revolution, adjust position, tighten.



Switchpoint cannot be lost. Even if you replace the sensor, the adjusted switchpoint is determined by the mounting bracket, not the sensor.

Ordering code

Advantages

Cylinder type

Mounting brackets

BMF 305-HW-17



T-slot



PX1207a

e.g. Festo, SMC

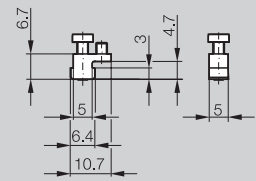

BMF 305-HW-20



T-slot

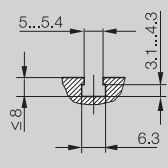

PX1287b

e.g. Festo, SMC

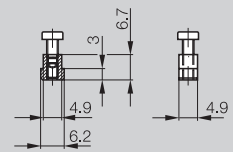

BMF 305-HW-22

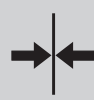

T-slot

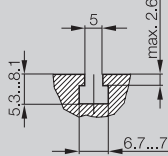

PX1305

e.g. Festo, Bosch

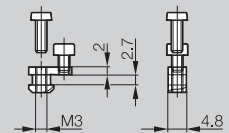

BMF 305-HW-23



T-slot

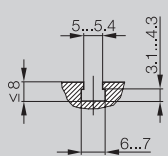

PX1306

e.g. Festo, SMC

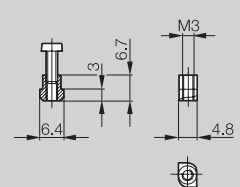

BMF 305-HW-24

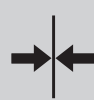

without slot

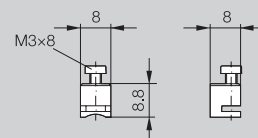

PX1341

round cylinder
with piston $\varnothing < 8...80$ mm



Hex Key Set



BMF Hex Key

Please order accessories separately see page 5.74

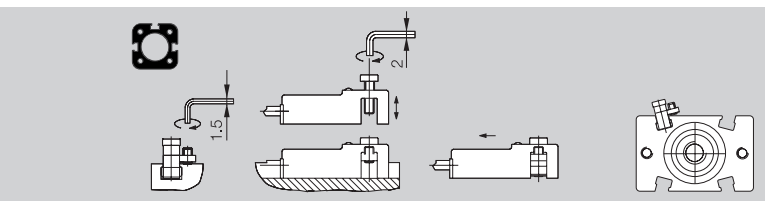
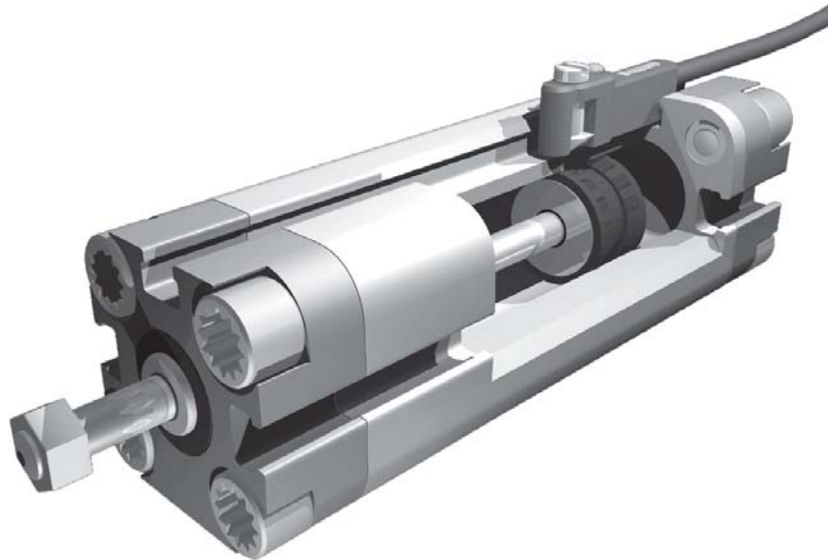

Installation notes

1. Insert mounting bracket in slot from front side
2. Insert sensor from above and tighten
3. Position sensor, bolt together mounting bracket

Included

Set screw DIN 916 M3×5-A2
Screw DIN 7984 M3×10-A2
Mounting bracket

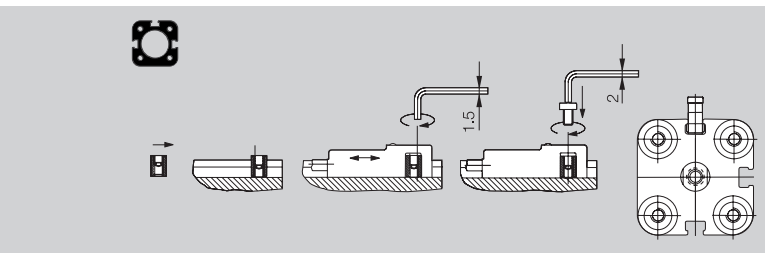

1. Insert mounting bracket into slot from head end
2. Insert sensor from above, position and tighten mounting bracket
3. Bolt together sensor with mounting bracket

Set screw DIN 916 M3×4-A2
Screw ISO 1207 M3×6-A2
Mounting bracket
also:
Screw DIN 7984 M3×6-A2

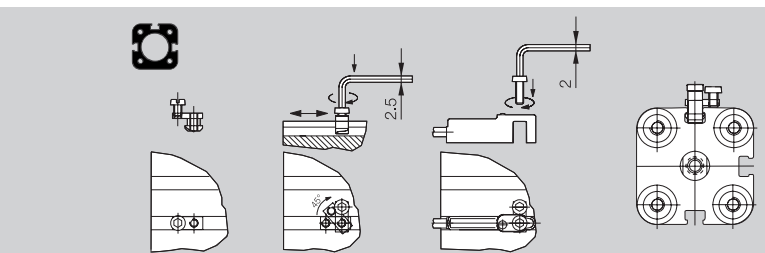

1. Insert mounting bracket from above into slot
Rotate 90°
2. Insert sensor from above and tighten
3. Position sensor, bolt together mounting bracket

Screw DIN 912 M3×4-A2
Screw DIN 7984 M3×8-A2
Mounting bracket
also:
Screw ISO 1207 M3×4-A2
Screw ISO 1207 M3×8-A2

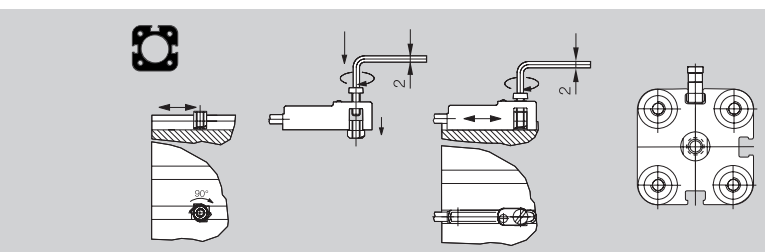

1. Attach mounting bracket to sensor with 1 to 2 turns
2. Insert sensor and mounting bracket from above and tighten (mounting bracket turns also 90°)

Screw DIN 7984-KL M3×10-A2
Mounting bracket
also:
Screw ISO 1207-KL M3×10-A2

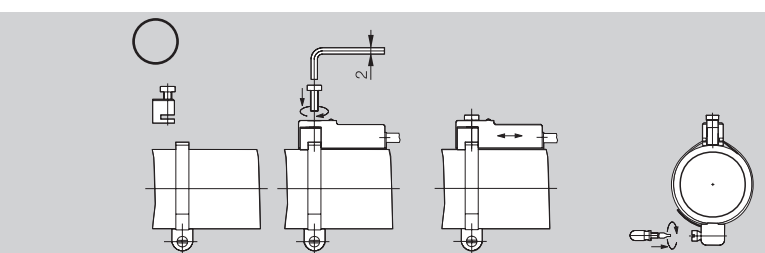

1. Place tube cuff on loosely
2. Attach sensor with mounting bracket to tube cuff
3. Position and tighten

Screw DIN 7984 M3×8-A2
Mounting bracket

For hose clamp matrix see
page **3.0.10**
(please order separately)

3.1

5

Connectors ...
page 5.2 ...

Sensors for Pneumatic Cylinders

Mounting brackets, selection guide, installation for BMF 305

Advantages



Can be installed in the slot from above. Anytime! Also afterwards! Fast! Saves time!



Switchpoint can be adjusted in seconds! Turn screw one revolution, adjust position, tighten.



Switchpoint cannot be lost. Even if you replace the sensor, the adjusted switchpoint is determined by the mounting bracket, not the sensor.

Ordering code

Advantages

Cylinder type

Mounting brackets

BMF 305-HW-25

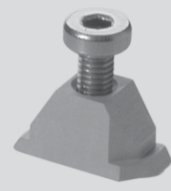

Trapezoidal slot 60°/90°

PX1343

e.g. Festo, Bosch, Numatics, Hoerbiger-Origa, Norgren-Martonair

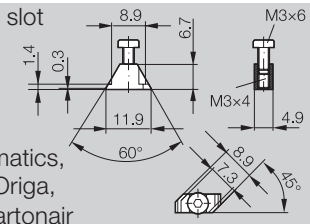

BMF 305-HW-26



T-slot A

Location for T-slot A

PX1419

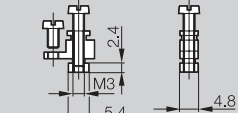
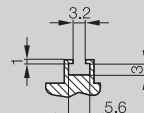

T-slot B

Location for T-slot B

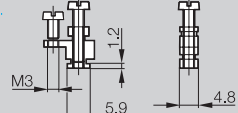
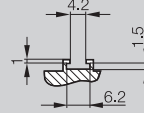

e.g. SMC

BMF 305-HW-27



Trapezoidal guide

PX1501

e.g. Bosch

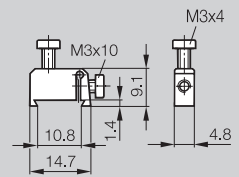

BMF 305-HW-32



C-slot

PX1537

e.g. Norgren

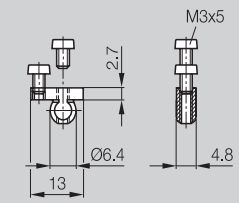

BMF 305-HW-64



C-slot

PX1900

e.g. Bosch

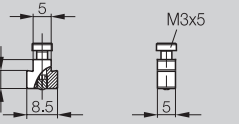

BMF 305-HW-21 and BMF 21-HW-8



PX1302d

for tie rod cylinders

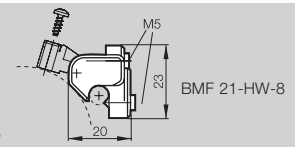

BMF 305-HW-21 and BMF 21-HW-10



PX1302c

for tie rod cylinders (profile shape)

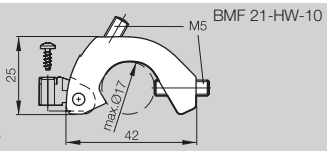

Hex Key Set



BMF Hex Key

Please order accessories separately see page 5.74

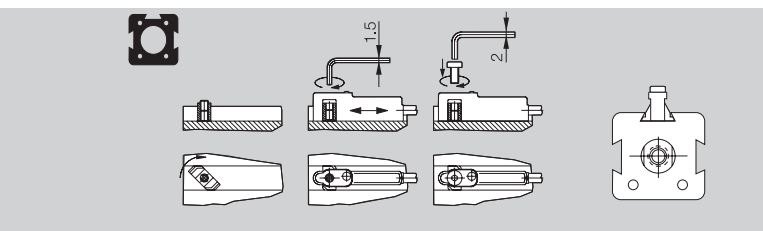

Installation notes

1. Insert mounting bracket from above and rotate 90°
2. Insert sensor, position, tighten mounting bracket
3. Screw sensor to mounting bracket

Included

Set screw DIN 916 M3×4-A2
Screw DIN 7984 M3×6-A2
Mounting bracket

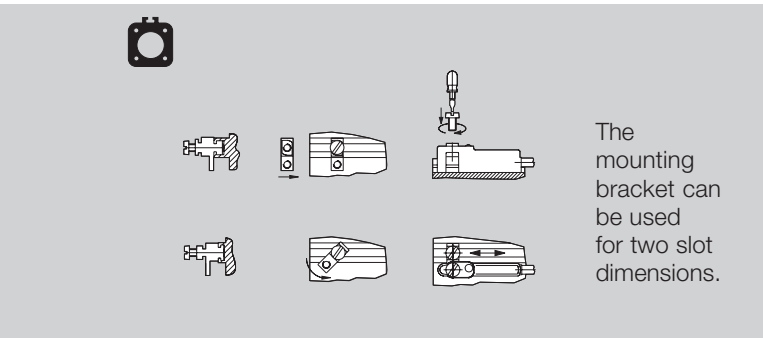

T-slot **A**: insert mounting bracket, insert sensor from above, position and tighten both screws.

Cheese head screw ISO 1207 M3×5 A2
Cheese head screw ISO 1207 M3×14 A2
Mounting bracket

T-slot **B**: insert mounting bracket from above and rotate 90°. Insert sensor from above, position and tighten both screws.

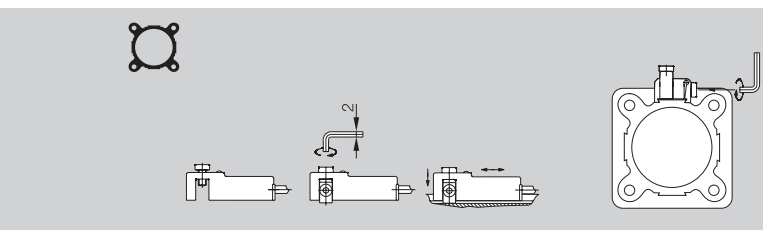

1. Insert mounting bracket from above
2. Insert sensor from above and tighten
3. Position sensor, tighten mounting bracket

Screw DIN 912 M3×4-A2
Screw DIN 7984 M3×10-A2
Mounting bracket

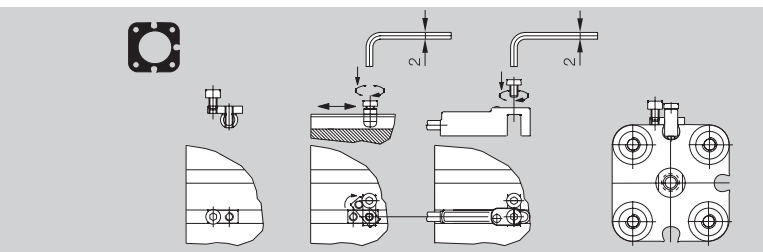

1. Insert mounting bracket from above and rotate 90°
2. Insert sensor, position, tighten mounting bracket
3. Screw sensor to mounting bracket

Screws DIN 7984 M3×5-A2
Mounting bracket

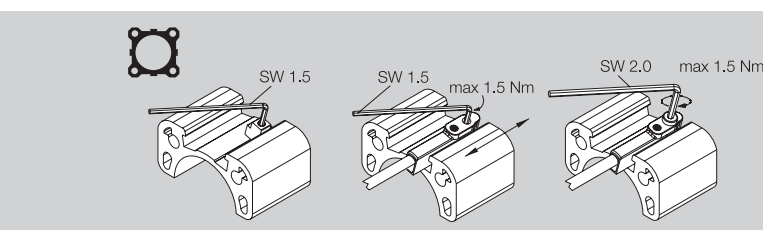

1. Mounting bracket in slot from above
2. Insert sensor from above, position and tighten mounting bracket
3. Bolt together sensor with mounting bracket

Cheese head screw DIN 7984 M3×5-A2,
Threaded stud DIN 914 M3×4-A2
Angled screwdriver 1.5 mm blade
Angled screwdriver 2.0 mm blade

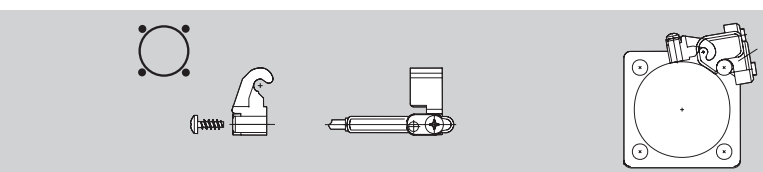

BMF 305-HW-21 used with BMF 21-HW-8 for attaching to a tie rod cylinder

PT-Screw KBL 30x8-A2
Mounting bracket
BMF 305-HW-21 (Mounting bracket BMF 21-HW-8 please order separately)

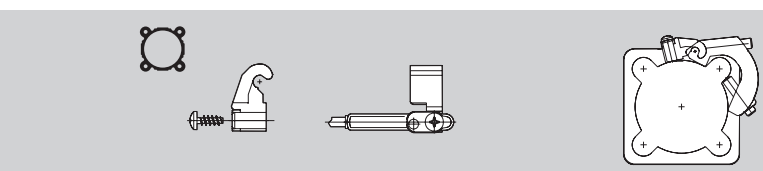

BMF 305-HW-21 used with BMF 21-HW-10 for attaching to a profile cylinder

PT-Screw KBL 30x8-A2
Mounting bracket
BMF 305-HW-21 (Mounting bracket BMF 21-HW-10 please order separately)

Series	BMF 305	BMF 305	BMF 305

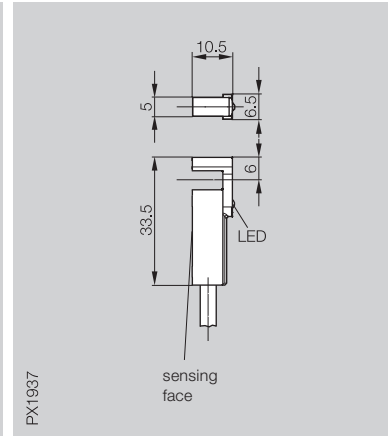
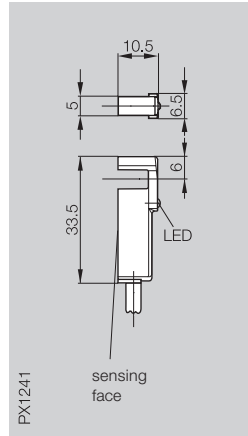
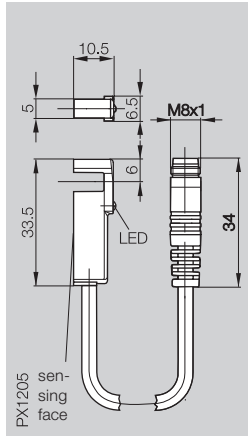

DC	NO, PNP	BMF 305K-R-PS-F-3-S49-00,2	BMF 305K-R-PS-F-3-03
AC NO / DC NO polarized			BMF 305K-R-US-L-3-03
Sensed medium	Magnetic field	Magnetic field	Magnetic field
Turn-on delay	≤ 0.7 ms	≤ 0.7 ms	≤ 0.7 ms
Turn-off delay	≤ 0.2 ms	≤ 0.2 ms	≤ 0.2 ms
Supply voltage U _B	10...30 V DC	10...30 V DC	6...240 V AC/DC
Switching capacity max. reed contact	10 W	10 W	10 W
Rated operational current I _e	500 mA	500 mA	128 mA at 24 V AC/DC 86 mA at 115 V AC/DC 43 mA at 230 V AC/DC
Minimum operating current I _m			3 mA
Polarity reversal protected	no	no	no
Short circuit protected	no	no	no
Ambient temperature range T _a	-20...+70 °C	-20...+70 °C	-20...+70 °C
Utilization category	DC 13	DC 13	AC 12/DC 12
Degree of protection per IEC 60529	IP 65	IP 65	IP 65
Housing material	LCP	LCP	LCP
Connection	0.2 m cable (PUR) with connector	3 m cable, PVC	3 m cable, PVC
No. of wires × cross-section		3×0.14 mm ²	2×0.18 mm ²
Approval			cULus
Recommended connector	BKS-_ 48		



Wiring diagrams

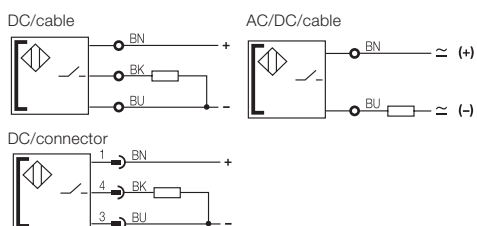

The **reed switches BMF 305K-R-...** have an LED for function indication and as a setup aid. The recovery diode for switching an inductive load is already integrated. For sensing the piston position in pneumatic cylinders you can choose between electronic and mechanical cylinder switches. Select whichever one fits your application.

We'll be glad to help you.

- Fast and easy to install
- Fits any standard cylinder size using available mounting brackets
- No loss of the switchpoint when replacing a switch

When using reed switches you should verify functionality on the pneumatic cylinder by means of pre-testing.