

AS30 Prime - Edge

Array Sensor

SICK
Sensor Intelligence.



Product described

AS30 Prime Edge

Manufacturer

SICK AG
Erwin-Sick-Str. 1
79183 Waldkirch
Germany

Legal information

This work is protected by copyright. Any rights derived from the copyright shall be reserved for SICK AG. Reproduction of this document or parts of this document is only permissible within the limits of the legal determination of Copyright Law. Any modification, abridgment or translation of this document is prohibited without the express written permission of SICK AG.

The trademarks stated in this document are the property of their respective owner.

© SICK AG. All rights reserved.

Original document

This document is an original document of SICK AG.



Contents

1	About this document.....	5
1.1	Information on the operating instructions.....	5
1.2	Scope.....	5
1.3	Explanation of symbols.....	5
1.4	Further information.....	6
1.5	Customer service.....	6
2	Safety information.....	7
2.1	Intended use.....	7
2.2	Improper use.....	7
2.3	Limitation of liability.....	7
2.4	Requirements for skilled persons and operating personnel.....	8
2.5	Hazard warnings and operational safety.....	8
2.6	Repair.....	8
3	Product description.....	9
3.1	Product ID.....	9
3.2	Product features and functions.....	10
4	Mounting.....	12
4.1	Scope of delivery.....	12
4.2	Installation requirements.....	12
4.3	Mounting the device.....	13
5	Electrical installation.....	14
5.1	Notes on electrical installation.....	14
5.2	Note on the swivel connector.....	15
5.3	Pin assignment of the connections.....	15
5.4	Connecting the supply voltage.....	15
5.5	Wiring the interfaces.....	16
6	Commissioning.....	18
7	Operation.....	19
7.1	Operating elements.....	19
7.2	Standard TFT displays.....	19
7.3	Navigation tree, general.....	20
7.4	Activating or deactivating the pushbutton lock.....	25
7.5	Resetting the device (factory setting).....	26
7.6	Teach-in.....	26
7.7	Area Teach.....	27
7.8	Additional settings.....	29
7.9	Additional settings via SOPAS.....	33
8	Troubleshooting.....	37

8.1	Possible errors during commissioning.....	37
8.2	Possible errors during operation.....	37
9	Maintenance.....	38
9.1	Maintenance.....	38
9.2	Cleaning the device.....	38
10	Decommissioning.....	40
10.1	Disassembly and disposal.....	40
10.2	Returning devices.....	40
11	Technical data.....	41
11.1	General data.....	41
11.2	Dimensional drawing.....	42
12	Accessories.....	44
13	Annex.....	45
13.1	EU declaration of conformity.....	45
13.2	Certification according to UL60947-5-2.....	45
13.3	Licences.....	45

1 About this document

1.1 Information on the operating instructions

These operating instructions provide important information on how to use devices from SICK AG.

Prerequisites for safe work are:

- Compliance with all safety notes and handling instructions supplied
- Compliance with local work safety regulations and general safety regulations for device applications

The operating instructions are intended to be used by qualified personnel and electrical specialists.



NOTE

Read these operating instructions carefully before starting any work on the device, in order to familiarize yourself with the device and its functions.

The instructions constitute an integral part of the product and are to be stored in the immediate vicinity of the device so they remain accessible to staff at all times. Should the device be passed on to a third party, these operating instructions should be handed over with it.

These operating instructions do not provide information on operating the machine in which the device is integrated. For information about this, refer to the operating instructions of the specific machine.

1.2 Scope

These operating instructions serve to incorporate the device into a customer system. Step-by-step instructions are given for all required actions.

These instructions apply to all listed device variants of the product.

Available device variants are listed on the online product page.

www.sick.com/AS30

Commissioning is described using one particular device variant as an example.

Simplified device designation in the document

In the following, the sensor is referred to in simplified form as “AS30 Prime Edge” or “device”.

1.3 Explanation of symbols

Warnings and important information in this document are labeled with symbols. The warnings are introduced by signal words that indicate the extent of the danger. These warnings must be observed at all times and care must be taken to avoid accidents, personal injury, and material damage.



DANGER

... indicates a situation of imminent danger, which will lead to a fatality or serious injuries if not prevented.

**WARNING**

... indicates a potentially dangerous situation, which may lead to a fatality or serious injuries if not prevented.

**CAUTION**

... indicates a potentially dangerous situation, which may lead to minor/slight injuries if not prevented.

**NOTICE**

... indicates a potentially harmful situation, which may lead to material damage if not prevented.

**NOTE**

... highlights useful tips and recommendations as well as information for efficient and trouble-free operation.

1.4 Further information

**NOTE**

All the documentation available for the device can be found on the online product page at:

▶ www.sick.com/AS30

The following information is available for download from this page:

- Type-specific online data sheets for device variants, containing technical data and dimensional drawings
 - EU declaration of conformity for the product family
 - Dimensional drawings and 3D CAD dimension models in various electronic formats
 - These operating instructions, available in English and German, and in other languages if necessary
 - Other publications related to the devices described here
 - Publications dealing with accessories
 - IO-Link device description IO-Link, driver file SDD for the configuration software SOPAS ET and technical information IO-Link v1.1.
-

1.5 Customer service

If you require any technical information, our customer service department will be happy to help. To find your agency, see the final page of this document.

**NOTE**

Before calling, make a note of all type label data such as type code, serial number, etc., to ensure faster processing.

2 Safety information

2.1 Intended use

The AS30 Prime Edge array sensor is an opto-electronic sensor for the optical, non-contact detection of contrast edges.

The array sensor is designed for mounting and may only be operated according to its intended function. For this reason, the array sensor is not equipped with direct safety devices.

The system designer must provide measures to ensure the safety of persons and systems in accordance with the legal guidelines.

SICK AG assumes no liability for losses or damage arising from the use of the product, either directly or indirectly. This applies in particular to use of the product that does not conform to its intended purpose and is not described in this documentation.

2.2 Improper use

- The device does not constitute a safety-relevant device according to the EC Machinery Directive (2006/42/EC).
- The device must not be used in explosion-hazardous areas.
- Any other use that is not described as intended use is prohibited.
- Any use of accessories not specifically approved by SICK AG is at your own risk.

The device is not suitable for the following applications (this list is not exhaustive):

- As a safety device to protect persons, their hands, or other body parts
- Underwater
- In explosion-hazardous areas
- Outdoors, without additional protection



NOTICE

Danger due to improper use!

Any improper use can result in dangerous situations.

Therefore, observe the following information:

- ▶ The device should be used only in line with intended use specifications.
- ▶ All information in these operating instructions must be strictly complied with.

2.3 Limitation of liability

Applicable standards and regulations, the latest state of technological development, and our many years of knowledge and experience have all been taken into account when assembling the data and information contained in these operating instructions. The manufacturer accepts no liability for damage caused by:

- Failure to observe the operating instructions
- Improper use
- Use by untrained personnel
- Unauthorized conversions
- Technical modifications
- Use of unauthorized spare parts, wear and tear parts, and accessories

With special variants, where optional extras have been ordered, or owing to the latest technical changes, the actual scope of delivery may vary from the features and illustrations shown here.

2.4 Requirements for skilled persons and operating personnel



WARNING

Risk of injury due to insufficient training!

Improper handling of the device may result in considerable personal injury and material damage.

- All work must only ever be carried out by the stipulated persons.

The operating instructions state the following qualification requirements for the various areas of work:

- **Instructed personnel** have been briefed by the operating entity about the tasks assigned to them and about potential dangers arising from improper action.
- **Skilled personnel** have the specialist training, skills, and experience, as well as knowledge of the relevant regulations, to be able to perform tasks assigned to them and to detect and avoid any potential dangers independently.
- **Electricians** have the specialist training, skills, and experience, as well as knowledge of the relevant standards and provisions to be able to carry out work on electrical systems and to detect and avoid any potential dangers independently. In Germany, electricians must meet the specifications of the BGV A3 Work Safety Regulations (e.g., Master Electrician). Other relevant regulations applicable in other countries must be observed.

The following qualifications are required for various activities:

Activities	Qualification
Mounting, maintenance	<ul style="list-style-type: none"> ■ Basic practical technical training ■ Knowledge of the current safety regulations in the workplace
Electrical installation, device replacement	<ul style="list-style-type: none"> ■ Practical electrical training ■ Knowledge of current electrical safety regulations ■ Knowledge of the operation and control of the devices in their particular application
Commissioning, configuration	<ul style="list-style-type: none"> ■ Basic knowledge of the design and setup of the described connections and interfaces ■ Basic knowledge of data transmission ■ Knowledge of the operation and control of the devices in their particular application
Operation of the devices in their particular application	<ul style="list-style-type: none"> ■ Knowledge of the operation and control of the devices in their particular application ■ Knowledge of the software and hardware environment in the application

2.5 Hazard warnings and operational safety

Please observe the safety notes and the warnings listed here and in other chapters of these operating instructions to reduce the possibility of risks to health and avoid dangerous situations.

2.6 Repair

The product is a replacement device. The device is not intended to be repaired. Interference with or modifications to the device on the part of the customer will invalidate any warranty claims against SICK AG.

3 Product description

3.1 Product ID

3.1.1 Type label

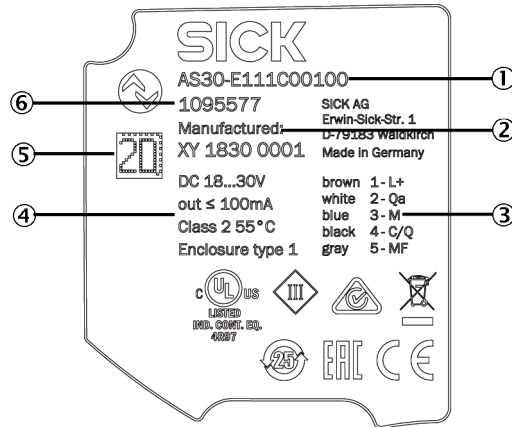

- ① device designation
- ② Date of manufacture and serial number
- ③ Pin assignment
- ④ Electrical data and environmental data
- ⑤ 2D-Code
- ⑥ Article number

3.1.2 Type code

Table 1: Type code

1	2	-	3	4	5	6	7	8	9	10	11	12	13	14
AS	30	-	E	B	M	4	3	4	I	2	1	0	A	00

Position	Meaning	
1	Basic type	AS = array sensor
2	Type number	30 = current generation
3	Application	E = edge W = width P = position C = center
4	Switching output	B = push/pull
5	Type of light	M = white
6	Field of view	3 = 30 mm 4 = 45 mm 5 = 50 mm
7	Distance	1 = 25 mm 3 = 100 mm
8	Connection	4 = M12, 5-pin, Qa, Q, MF
9	Communication	I = IO-Link
10	HMI	1 = LED +3 buttons 2 = TFT +3 buttons

Position	Meaning	
11	Core/Prime/Pro	1 = Core 2 = Prime 3 = Pro
12	Filter	0 = no filter
13	Type of device	M = sample device S = special device A = SMART Task B = special device with SMART Task Z = standard
14	Sequential no. for SMART Task/special/sample	01 = 0 ... (= Increment = 1) 99 = 0 ZZ = standard

3.2 Product features and functions

3.2.1 Device view

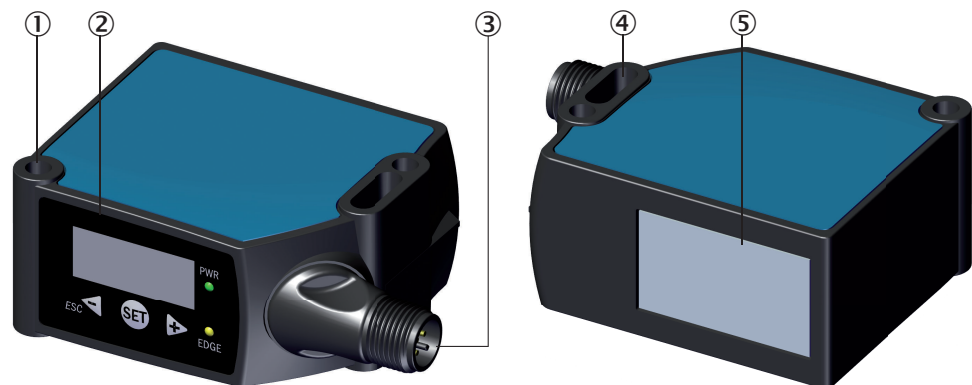

Figure 1: AS30 Prime Edge

- ① Fixing hole
- ② Display and control panel
- ③ Connection
- ④ Fixing hole
- ⑤ Light emission

3.2.2 Product characteristics

The array sensors can be used in any application that requires the detection of one (AS30 Prime Edge Mode) or two edges (AS30 Prime Width Mode) based on a clear contrast difference. With two edge devices, the edge distance (width) or center point (center line) is also output as an option.

Edges with a low contrast difference on transparent or reflective materials can be detected in the Reflector setting, see "[Selection of reflector / sensing mode](#)", page 30 .

This variant of the AS30 Prime Edge Mode provides 2 operating modes:

- Detection and positioning of an edge, for example for edge guiding (smoothed position value)

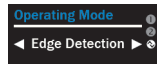

- Detection and positioning of an edge for highly accurate positioning (accurate position value)



4 Mounting

4.1 Scope of delivery

- Array sensor in the version ordered
- Quickstart
- Reflector film
- Alignment aid

4.2 Installation requirements

- For the typical space requirements for the device, see the type-specific dimensional drawing, [see "Technical data", page 41](#).
- Comply with technical data, such as the permitted ambient conditions for operation of the device (e.g., temperature range, EMC interference emissions, ground potential).
- To prevent condensation, avoid exposing the device to rapid changes in temperature.
- Protect the device from direct sunlight.
- The device must only be mounted using the pairs of fixing holes provided for this purpose.
- Shock and vibration resistant mounting.

4.3 Mounting the device

1. Install the sensor via the fixing hole so that the light spot is positioned (longitudinally or transversely depending on the operating mode) on the object to be detected. **Observe the sensing range variation and tolerances.**

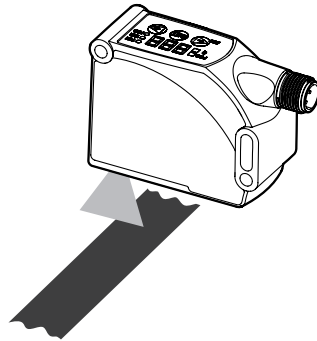

2. In the case of high-gloss materials, angle the AS30 Prime Edge at $> 8^\circ$ at the side for better detection reliability.

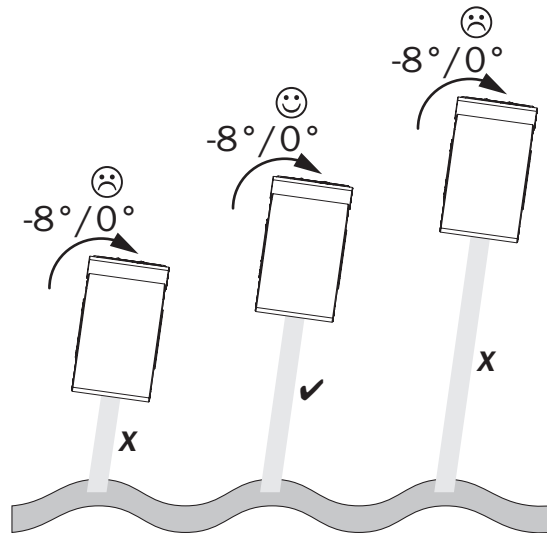

Table 2: Sensing distances

25 mm	100 mm
1095579	1095580

3. When detecting transparent materials, the reflector foil included with delivery must be positioned behind the object to be detected and the sensor must be used in reflector mode (see "Selection of reflector / sensing mode", page 30.)
4. The AS30 Prime Edge has a supporting alignment mode that can be called up via the display (see "Commissioning", page 18) or via SOPAS. To do so, position the supplied alignment aid in the field of view.

5 Electrical installation

5.1 Notes on electrical installation

**NOTICE****Equipment damage due to incorrect supply voltage!**

An incorrect supply voltage may result in damage to the equipment.

- Only operate the device with safety/protective extra-low voltage (SELV/PELV).
 - The sensor is a device of protection class III.
-

**NOTICE****Equipment damage due to incorrect supply voltage!**

An incorrect supply voltage may result in damage to the equipment.

- Only operate the device with an LPS (limited power source) in accordance with IEC 60950-1 or an NEC Class 2 power supply unit.
-

**NOTICE****Equipment damage or unpredictable operation due to working with live parts!**

Working with live parts may result in unpredictable operation.

- Only carry out wiring work when the power is off.
 - Only connect and disconnect electrical connections when the power is off.
-

- **The electrical installation must only be performed by electrically qualified personnel.**
 - **Standard safety requirements must be observed when working on electrical systems!**
 - Only switch on the supply voltage for the device when the connection tasks have been completed and the wiring has been thoroughly checked.
 - When using extension cables with open ends, ensure that bare wire ends do not come into contact with each other (risk of short-circuit when supply voltage is switched on!). Wires must be appropriately insulated from each other.
 - Wire cross-sections in the supply cable from the user's power system must be selected in accordance with the applicable standards.
 - Only operate the device with an LPS (limited power source) in accordance with IEC 60950-1 or an NEC Class 2 power supply unit.
 - All circuits connected to the device must be designed as SELV/PELV circuits.
-

**NOTE****Layout of data cables**

- Implement the shielding design correctly and completely.
 - To avoid interference, e.g., from switching power supplies, motors, clocked drives, and contactors, always use cables and layouts that are suitable for EMC.
 - Do not lay cables over long distances in parallel with voltage supply cables and motor cables in cable channels.
-

The IP enclosure rating for the device is only achieved under the following conditions:

- The cables plugged into the connections are screwed tight.

If these instructions are not complied with, the IP enclosure rating for the device is not guaranteed!

5.2 Note on the swivel connector



NOTICE

Damage to the connector unit from over-tightening!

The connector unit on the device has two opposite end positions.

- Do not rotate the connector unit from either of the two end positions by more than 180°.

5.3 Pin assignment of the connections

AS30	
1 - BN	L+
2 - WH	Qa
3 - BU	M
4 - BK	C/Q
5 - GY	MF

Legend

L+ = Supply voltage

Qa = Analog output (edge information)

M = Ground

C/Q = Communication and switching output

MF = External input, external teach-in, QI1 output, QI2 output, background teach-in, input for changing the reading and searching direction



NOTICE

Crosstalk can occur on the analog output in IO-Link operation. Simultaneous operation is not recommended.

5.4 Connecting the supply voltage



NOTICE

Risk of damage to the device!

The device can become damaged if it is connected to a voltage supply that is already switched on.

- Only connect the device when the supply cable is de-energized.

The device must be connected to a power supply unit with the following properties:

- Supply voltage DC 18 V – 30 V (SELV/PELV as per currently valid standards)
- Electricity source with at least 3.1 W power

To ensure protection against short-circuits/overload in the customer's supply cables, the wire cross-sections used must be appropriately selected and protected.

5.5 Wiring the interfaces

5.5.1 Wiring the digital inputs

Voltage level at the input starts the corresponding function of the device.

Electrical values

High: $12\text{ V} \leq U \leq U_V$

Low: $0\text{ V} \leq U \leq 9\text{ V}$

5.5.2 Wiring the digital outputs

In each case, the digital outputs are short-circuit protected and overcurrent protected.

Push/pull switching behavior

Electrical values

The sum current (100 mA) must be switched on for all digital outputs.

Push/pull

High: $V_S - 3\text{ V}$

Low: $\leq 3\text{ V}$

In the case of a push/pull sensor with PNP switching behavior, the signal must be inverted in the control system in order to obtain the same result as a sensor with NPN switching behavior.

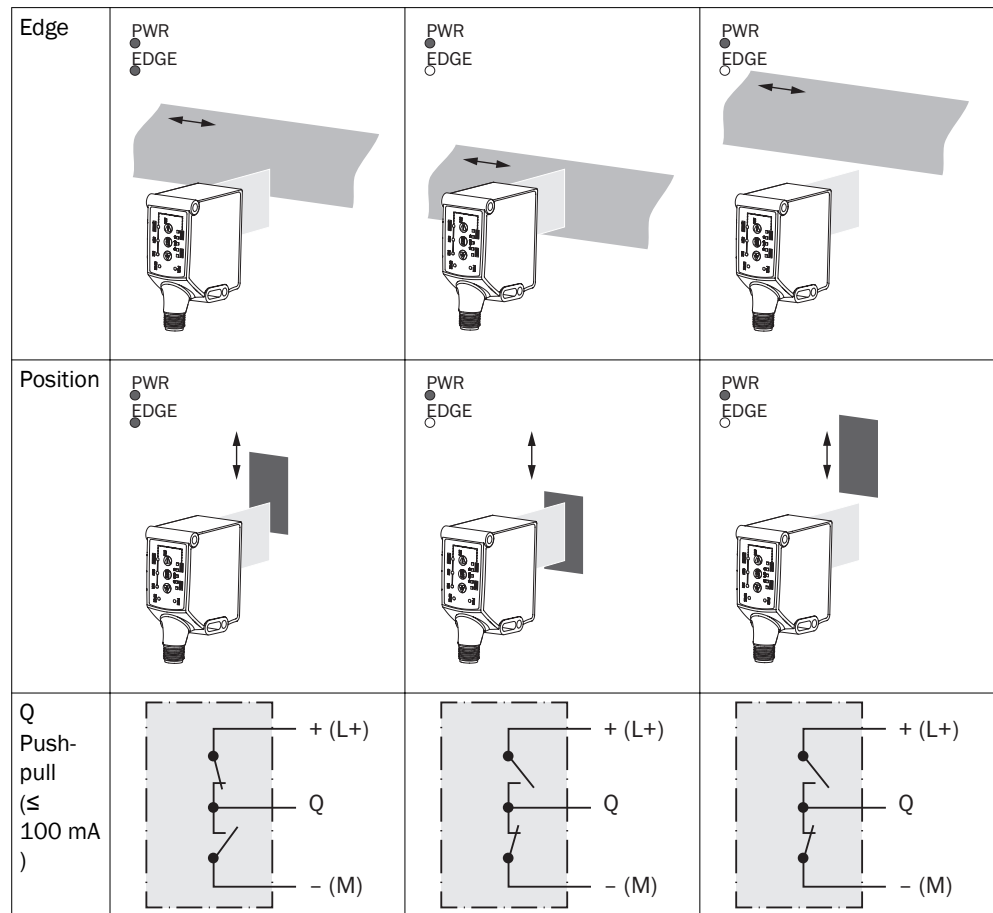

6 Commissioning

To commission the device, it is necessary to accurately align the device as described in see "Mounting the device", page 13.

Fine adjustment is done in the Diagnosis > Alignment menu.

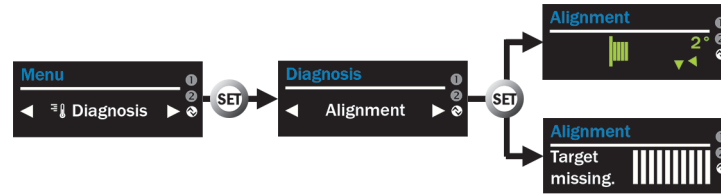

Figure 2: Alignment menu

Preparation

1. Position the supplied alignment aid in the field of view of the sensor.

In the Diagnosis menu

1. Select the Alignment menu with the +/- pushbutton
2. Open the Alignment menu with the SET pushbutton
3. Press the SET pushbutton to start the process
 - Target missing: Alignment aid not in field of view.
 - The number and color of the filling bar graph signals the spacing of the sensing distance from the nominal sensing distance. The specification of the angle indicates the tilt of the sensor in the longitudinal direction.

7 Operation



NOTICE

In this chapter, the operation of the sensor from the control panel or via the SOPAS configuration software is described.

The SOPAS ET software can be downloaded from the following link: <https://www.sick.com/de/en/sopas-engineering-tool-2018/p/p367244>

The driver for this product can be found at www.sick.com/AS30.

This chapter will first describe how to operate the sensor from the control panel.

Some additional settings that are not available from the control panel are described in see "Additional settings via SOPAS".

7.1 Operating elements

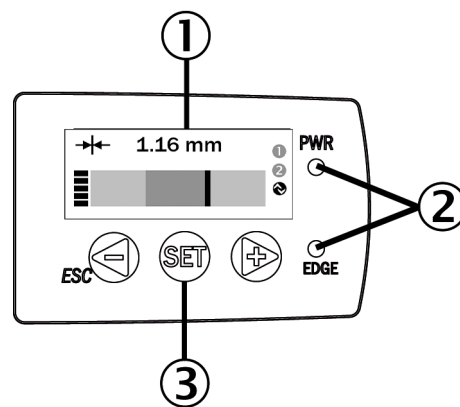

Figure 3: Operating elements



Table 3: Operating elements and functions

Number	Name	Function
1	TFT display	Shows menu item, values, or qualities.
2	PWR LED display	Illuminates when the voltage supply is connected.
2	EDGE LED display	Lights up when an edge is detected in the field of view.
3	Plus (+) pushbutton	Navigates through menu items or increases values.
3	SET pushbutton	Opens the menu, confirms entries, or switches to lower-level menus.
3	Minus (-)/ESC pushbutton	Switches to the previous menu item, decreases values or changes to Run mode (press for > 3 s).

7.2 Standard TFT displays

Table 4: Standard TFT displays

TFT	Handling	Result
	Confirm with SET pushbutton	Back to the higher menu level
	--	Setting saved

TFT	Handling	Result
	--	Setting saved Back to the higher menu level
	To lock the pushbutton, press + for > 10 s	Locked, the setting cannot be changed
	To unlock the pushbutton, press + for > 10 s	Unlocked, this setting can be changed

7.3 Navigation tree, general

Navigating

Selecting menu

1. Press the SET pushbutton to start navigation
 - The last active main menu (1st level) is displayed
2. Open the menu selection with the SET pushbutton
3. Select the desired menu with the +/- pushbutton
4. Open the desired menu with the SET pushbutton

Exiting the menu with Back

1. Select Back with the +/- pushbutton
2. Confirm with SET pushbutton
 - The higher-level menu is active

Cancel and go back to the start screen in RUN mode

1. Press ESC/- pushbutton for > 3 s
 - The sensor shows the start screen in RUN mode

7.3.1 AS30 Prime menu tree

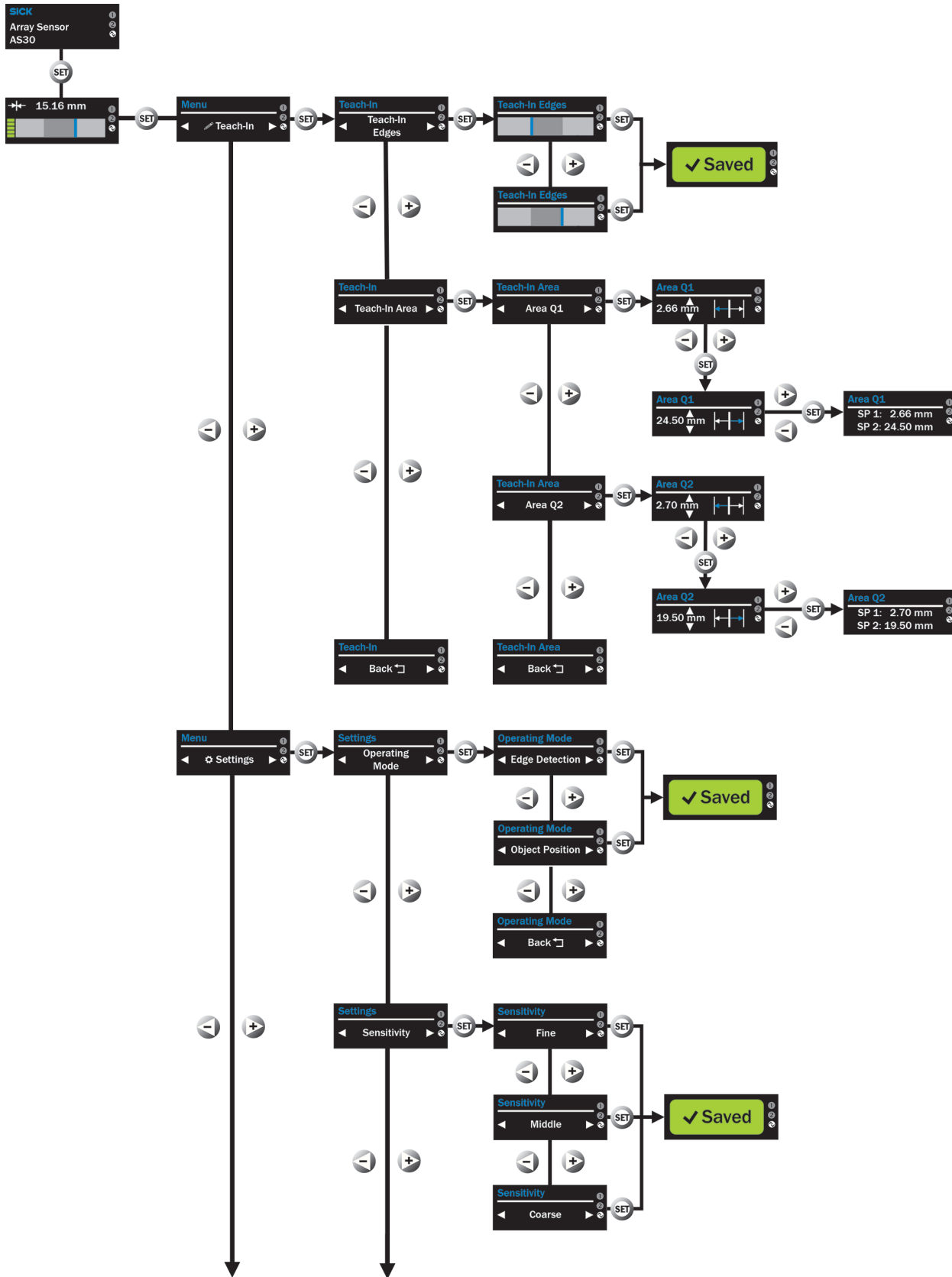

Figure 4: Menu tree with Teach-In and Settings / Operating Mode / Sensitivity menus

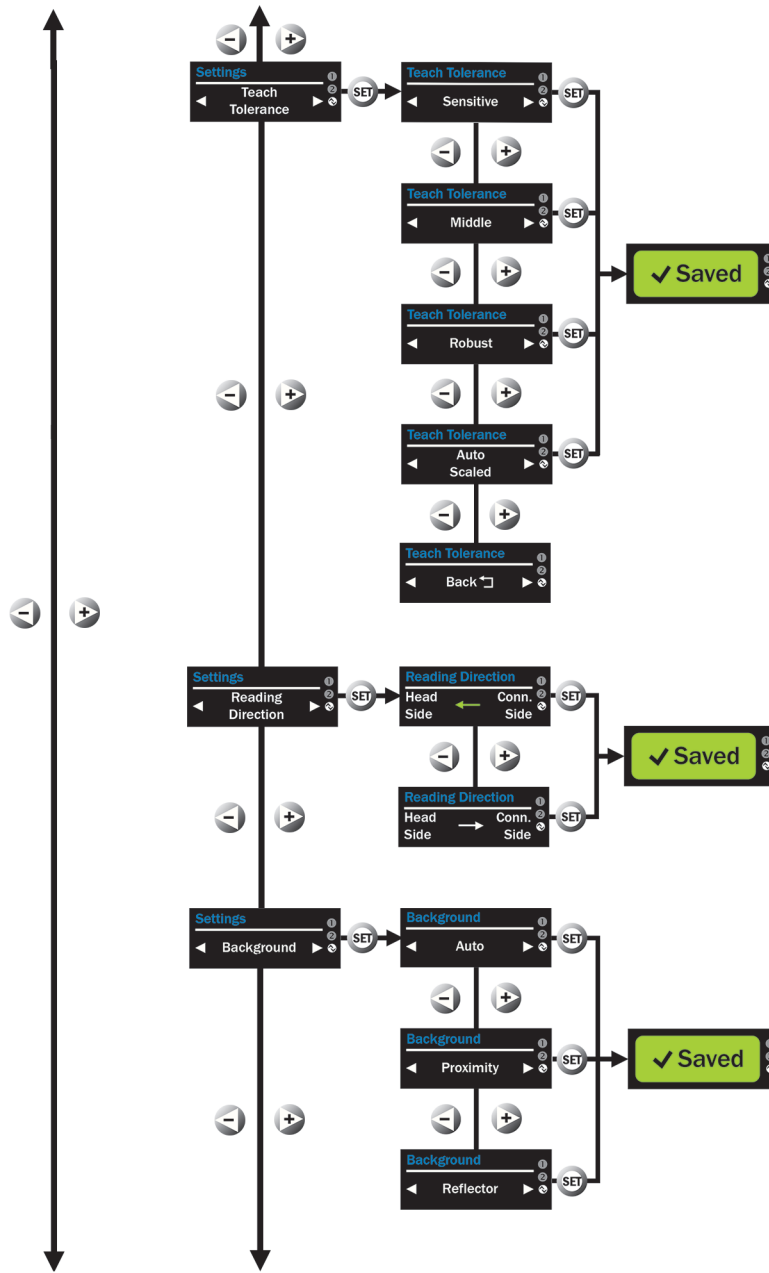

Figure 5: Menu tree with Settings / Teach Tolerance / Reading Direction / Background menus

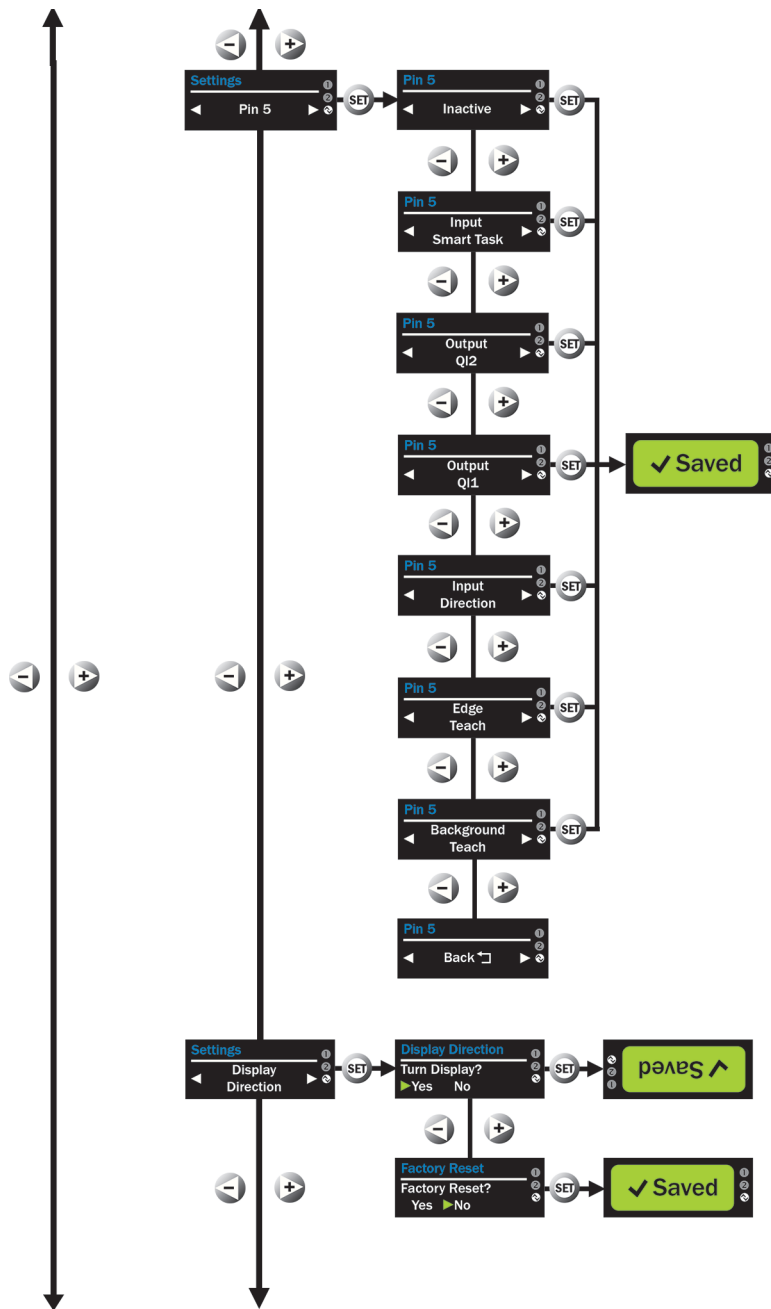

Figure 6: Menu tree with Settings / Pin 5 / Display Direction menu

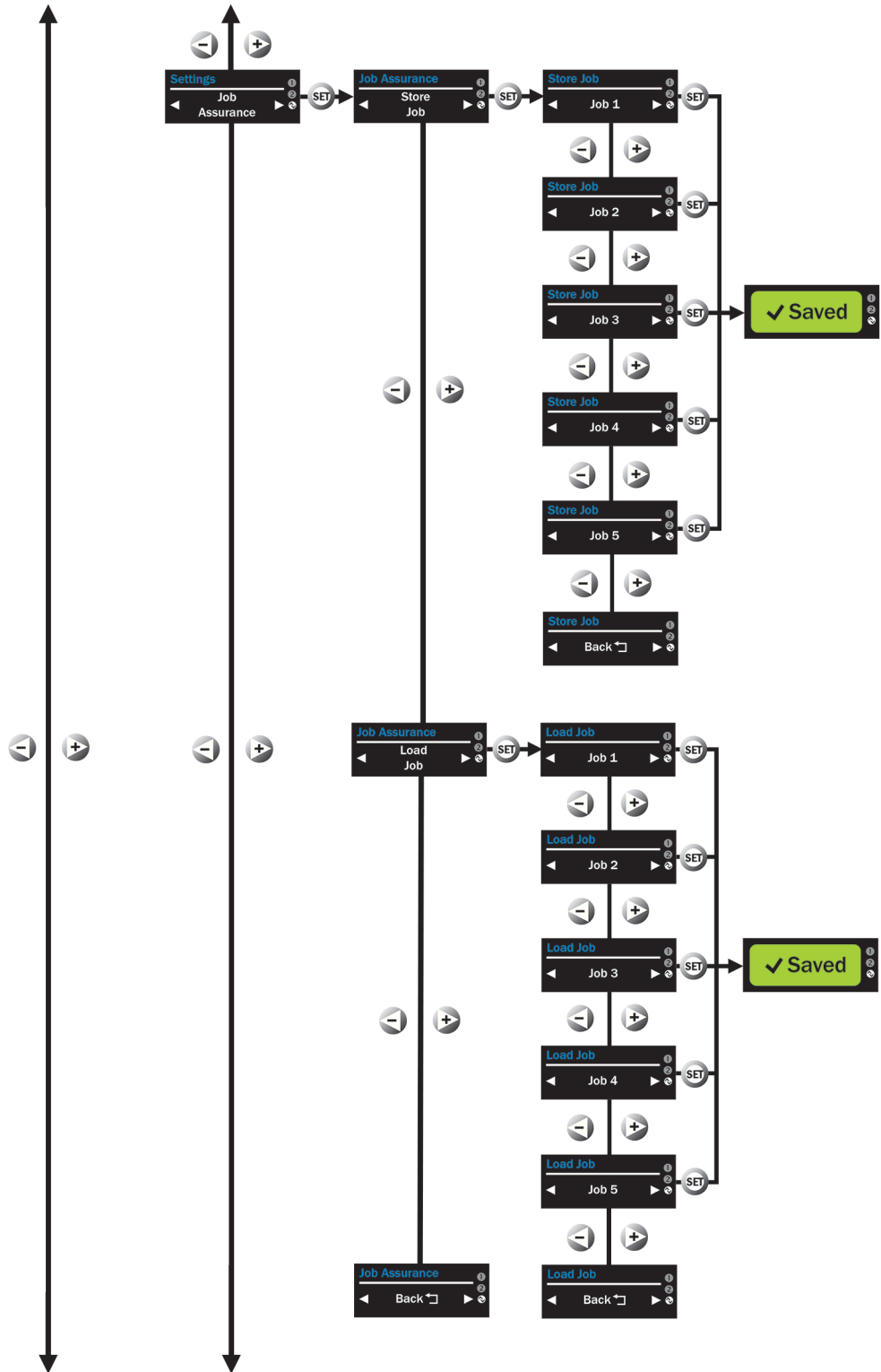

Figure 7: Menu tree with Settings / Teach Tolerance / Job Assurance menus

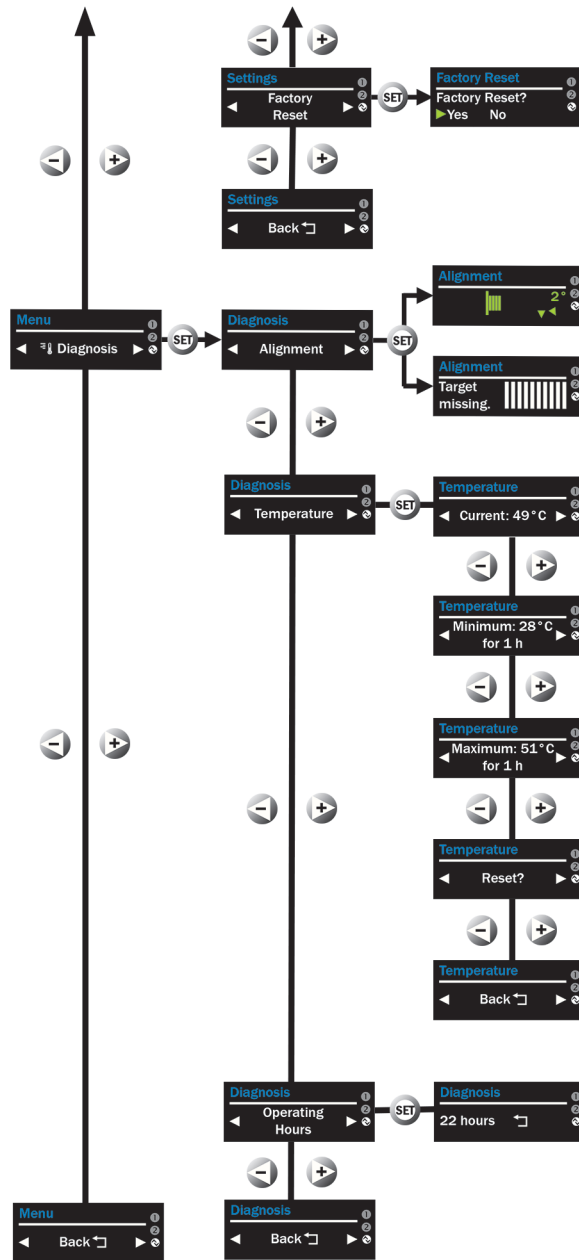

Figure 8: Menu tree with Settings / Factory Reset and Diagnosis menus

7.4 Activating or deactivating the pushbutton lock

Activating pushbutton lock

1. Press and hold the + pushbutton > 10 s
 - Pushbutton lock activated



Deactivating pushbutton lock

1. Press and hold the + pushbutton > 10 s
 - Pushbutton lock deactivated



7.5 Resetting the device (factory setting)

Resetting to factory settings deletes all saved settings (jobs).



Figure 9: Factory Reset menu

In the Settings menu

1. Select the Factory Reset menu with the +/- pushbutton
2. Open the Factory Reset menu with the SET pushbutton
3. Select Factory Reset YES with the +/- pushbutton
4. Confirm the selection with the SET pushbutton
 - The display shows OK
5. Confirm the OK request with the SET pushbutton
 - The display shows RESET. The factory settings are active.

7.6 Teach-in

7.6.1 Teach-in - factory setting

By default, the detection of an edge also works without teach-in.

The sensor detects the first edge in the field of view starting from the male connector side. The sensor switches as soon as an edge appears in the field of view.

With the default settings, the analog output on pin 2 outputs the current in mA (4...20 mA) equivalent to the edge position. The associated position value in mm is shown in the display.

Only the taught-in edge is detected after a teach-in. This can increase the process reliability in some applications.

7.6.2 Teach-in on the display

7.6.2.1 Teaching in edge

The device can be taught in on a specific edge with the Teach-In menu.

The specific edge must be in the field of view to ensure teach-in is successful. The sensor switches as soon as the taught-in edge appears in the field of view. The edge is defined using the contrast difference between its two areas as well as the steepness of the contrast gradient (hard or soft edge). With the default settings, the analog output on pin 2 outputs the edge position value. This appears in the display.

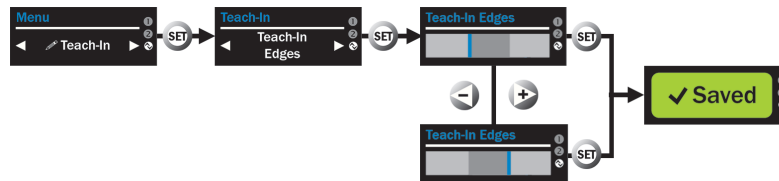

Figure 10: Teach-In Edges menu

In the Teach-In menu

1. Select Teach-In Edges menu with +/- pushbutton
2. Open Teach-In Edges menu with SET pushbutton
3. Select the desired edge with the +/- pushbutton
4. Confirm the selection with the SET pushbutton
 - The display shows SAVED

7.6.2.2 Setting edge teach tolerance

Principle of operation: Edges deviating from the taught-in edge are detected, but no switching signal is output.

The deviation (contrast difference and edge sharpness) with which the taught-in edge is differentiated from the other edges is set in the Teach Tolerance menu.

The available options are

- Sensitive
- Middle
- Rugged
- Auto Scaled: The Teach Tolerance is selected depending on the general sensor sensitivity, see "Setting sensor sensitivity", page 29.



NOTICE

If a taught-in edge is not detected, set the teach tolerance to be more rugged.
If unwanted edges are detected, set the teach tolerance to be more sensitive.

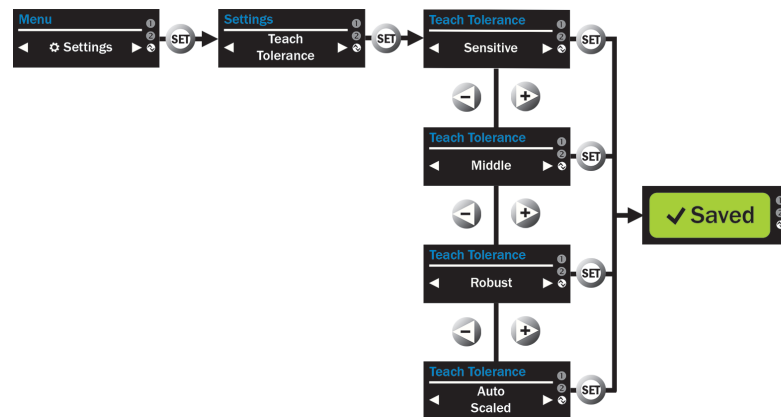

Figure 11: Teach Tolerance menu

In the Settings menu

1. Select Teach Tolerance menu with +/- pushbutton
2. Open Teach Tolerance menu with SET pushbutton
3. Select the desired sensitivity with the +/- pushbutton
4. Confirm the selection with the SET pushbutton
 - The display shows SAVED

7.6.3 Teach-in - external teach

Pin 5 must be configured accordingly to execute Teach-In Edges via an external input, see "Pin 5 configuration", page 31.

The first edge in the reading direction is taught in at the HIGH input.

7.7 Area Teach

After the edges have been taught in with Teach-In Edges, the switching points of the Q11 and Q12 switching outputs can be defined in the Area menu. The edges must be located in the field of view.

Switching areas for Q1 and for Q2 are available for selection.

In the Width operating mode, the lower switching point corresponds to the smallest acceptable width (distance of the taught-in edge 1 to 2), the upper switching point to the maximum width. The value entered expands the allowed width starting at the width at the time of teach-in.

In the Center operating mode, the switching points are each before or after the position of the center line at the time of teach-in.

- Switching point 1 for the area before the taught-in edge, the mm value can be changed with the +/- pushbutton.

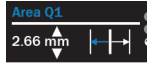
Example, switching point 1 for Area Q1: 

- Switching point 2 for the area after the taught-in edge, the mm value can be changed with the +/- pushbutton.

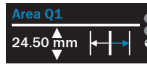
Example, switching point 2 for Area Q1: 

Q1 or Q2 HIGH are in the area between the configured limits.

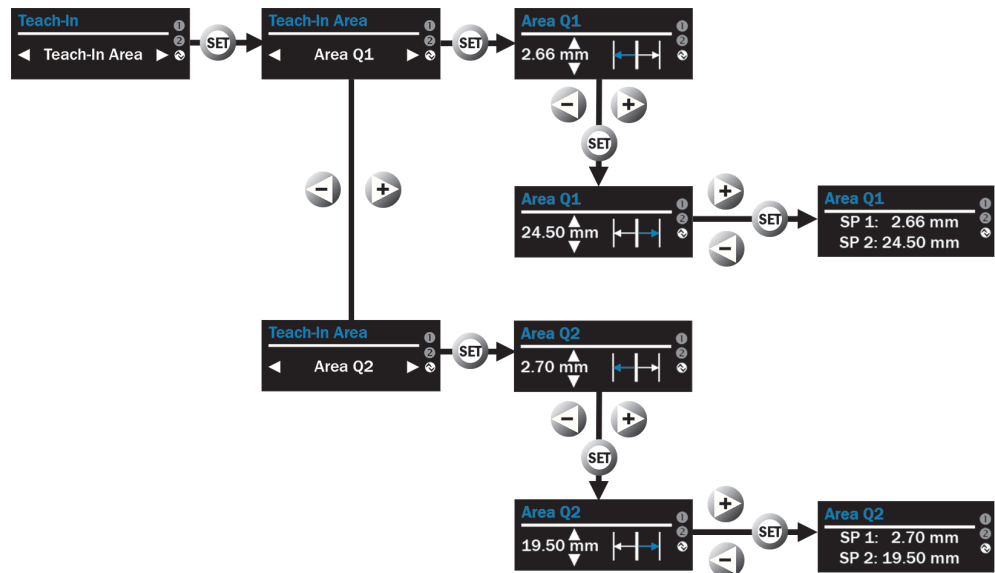
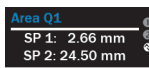
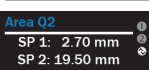

Figure 12: Area Teach menu

In the Teach-In menu

1. Select Teach-In Area menu with +/- pushbutton
2. Open Teach-In Area menu with SET pushbutton
3. Using the +/- pushbutton, select the Teach-In Area Q1 or Teach-In Area Q2 menu and open with the SET pushbutton
4. Set switching point 1 and switching point 2 with the +/- pushbutton
5. Confirm the settings with the SET pushbutton
 - The display shows the values of switching point (SP) 1 and switching point (SP) 2

Example, Area Q1: 

Example Area Q2: 

6. Save the setting with the SET pushbutton
 - The display shows SAVED

7.8 Additional settings

7.8.1 Setting operating mode

The operating mode determines how the edge is detected by the sensor.

The available options are

- **Edge Detection**

The edge selected in the Teach-In Edges menu is detected within tolerances values. The smoothing function of the sensor, which smooths position values over a 33 ms period, is automatically active. This ensures steady and stable edge guiding. The time interval for smoothing is configured via IO-Link and SOPAS.

- **Position**

The edge selected in the Teach-In Edges menu is positioned precisely. The smoothing function of the sensor is deactivated.

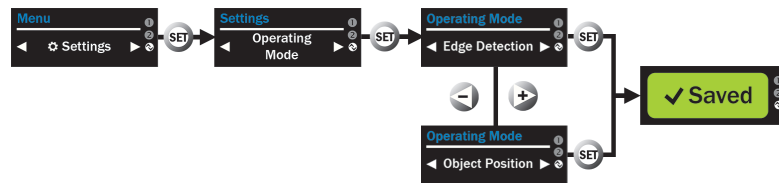

Figure 13: Operating Mode menu

In the Settings menu

1. Select the Operating Mode menu with the +/- pushbutton
2. Open the Operating mode menu with the SET pushbutton
3. Select the desired mode with the +/- pushbutton
4. Confirm the selection with the SET pushbutton
 - The display shows SAVED

7.8.2 Setting sensor sensitivity

The sensitivity determines with which sensitivity the sensor generally reacts to detected edges.

The sensitivity set here is relevant for the Teach Tolerance > Auto Scaled setting, see ["Setting edge teach tolerance", page 27](#). In this case, the sensitivity set here is adopted for the edge teach tolerance.

The available options are

- Fine (highly sensitive, for the detection of fine edges)
- Middle (standard sensitivity setting)
- Coarse (not very sensitive, for the detection of obvious edges)

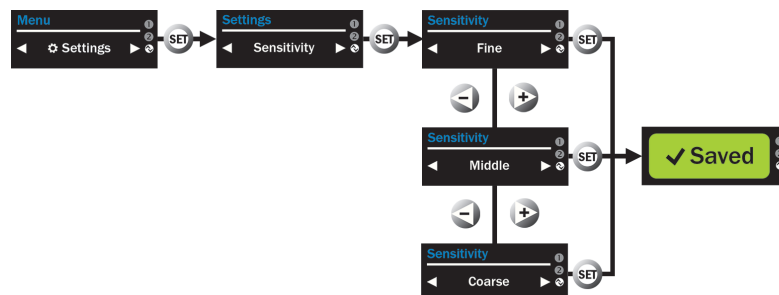

Figure 14: Sensitivity menu

In the Settings menu

1. Select the Sensitivity menu with the +/- pushbutton

2. Open the Sensitivity menu with the SET pushbutton
3. Select the desired sensitivity with the +/- pushbutton
4. Confirm the selection with the SET pushbutton
 - The display shows SAVED

7.8.3 Setting reading direction

The AS30 Prime Edge offers 2 reading directions for the sensor.

The millimeter values of the edge position are output in the configured direction. The analog output on pin 2 switches accordingly.

The available options are

- From male connector to head side (default)



- From head side to male connector

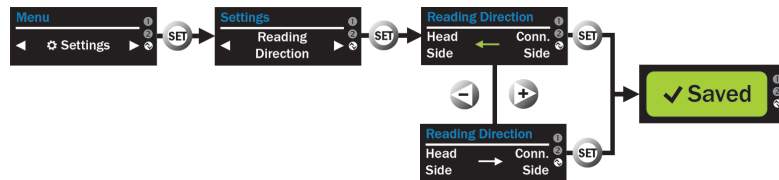

Figure 15: Reading Direction menu

In the Settings menu

1. Select the Reading Direction menu with the +/- pushbutton
2. Open the Reading Direction menu with the SET pushbutton
3. Select the desired direction with the +/- pushbutton
4. Confirm the selection with the SET pushbutton
 - The display shows SAVED

7.8.4 Selection of reflector / sensing mode

You can choose between reflector or sensing mode.

The reflector option is recommended for very glossy or (semi-)transparent objects.

With the auto option, the sensor automatically detects a mounted reflector in the background.

If this setting is selected during operation, the sensor must be restarted. If an edge is taught in, the background set in the auto option is retained.



NOTICE

Mounting the reflector 10-20 mm behind the object is recommended in the reflector option.

The reflector can be taught in using different methods in order to ignore any edges on the reflector:

- IO-Link see ["Pin assignment of the connections", page 15](#)
- SOPAS configuration software see ["Additional settings via SOPAS", page 33](#)
- External trigger on pin 5 see ["Pin 5 configuration", page 31](#)

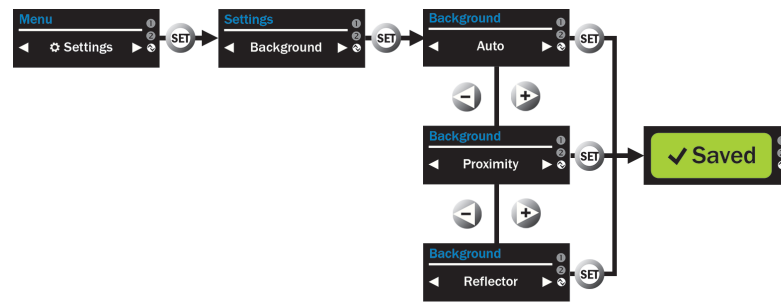
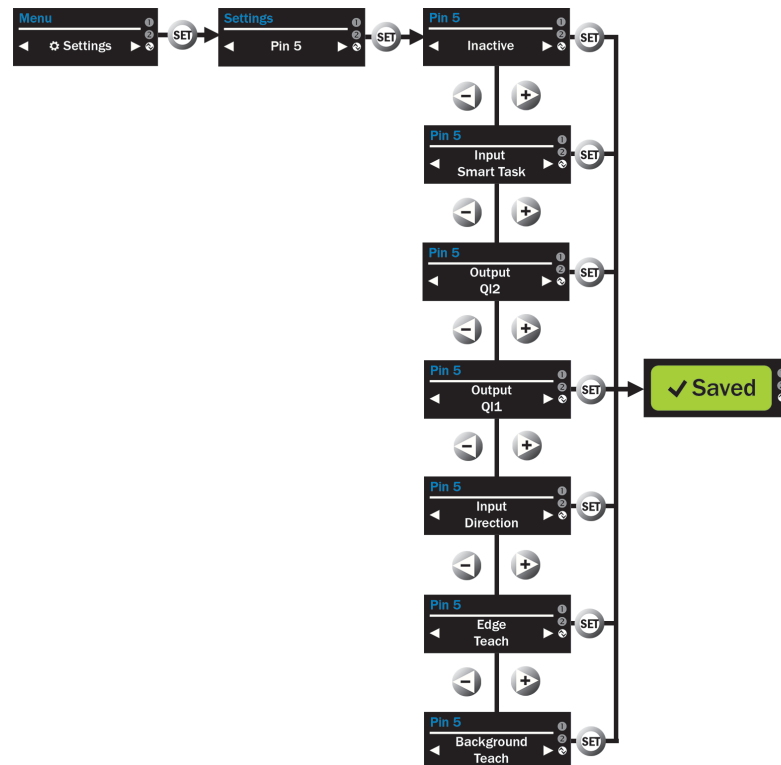

Figure 16: Background menu

In the Settings menu

1. Select the Background menu with the +/- pushbutton
2. Open the Background menu with the SET pushbutton
3. Select the operating mode with the +/- pushbutton
4. Confirm the selection with the SET pushbutton
 - The display shows SAVED

7.8.5 Pin 5 configuration



In the Settings menu

1. Select the Pin 5 menu with the +/- pushbutton
2. Open the Pin 5 menu with the SET pushbutton
3. Select the desired option with the +/- pushbutton
4. Confirm the selection with the SET pushbutton
 - The display shows SAVED

7.8.6 Aligning display

If the sensor is mounted at a 180° rotated position, the display can be rotated accordingly.

The available options are

- Turn Display YES



- Turn Display NO

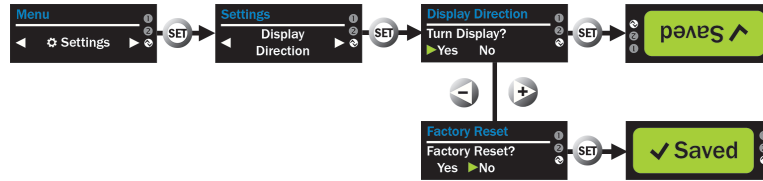

Figure 17: Display Direction menu

In the Settings menu

1. Select the Display Direction menu with the +/- pushbutton
2. Open the Display Direction menu with the SET pushbutton
3. Select the desired direction with the +/- pushbutton
4. Confirm the selection with the SET pushbutton
 - The display shows SAVED in the respective direction

7.8.7 Saving and loading jobs

Stored parameter sets (jobs) make it possible to permanently save and call up specific application parameters (e.g., taught-in edges, area, sensitivity, etc.) in the device for certain applications.

The device has 5 memory locations (Job 1 to Job 5).

The available options are

- **Store Job**
Saves the active settings on the selected Job 1 to Job 5 memory locations. Any parameters in this memory location are overwritten.
- **Load Job**
Loads the parameter available at the selected memory location. The active parameters are overwritten.

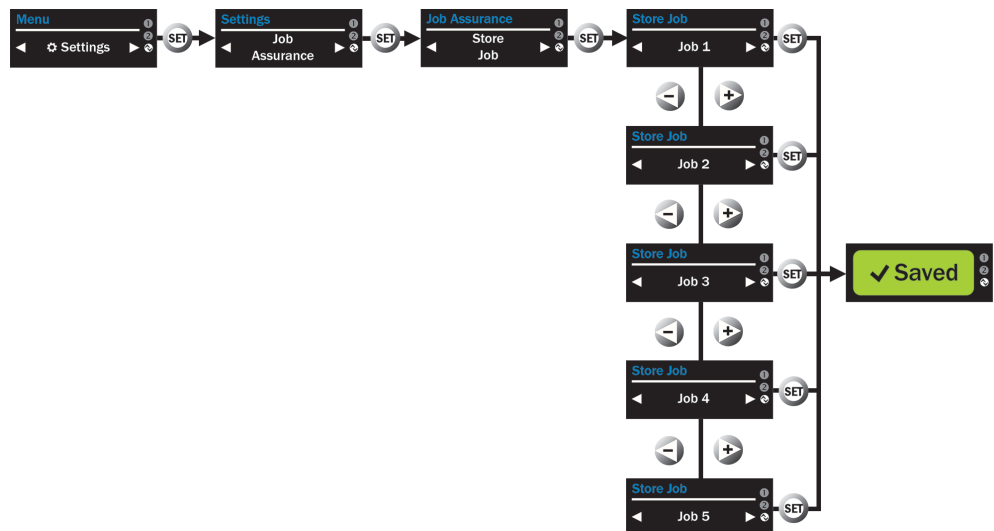

Figure 18: Store Job menu

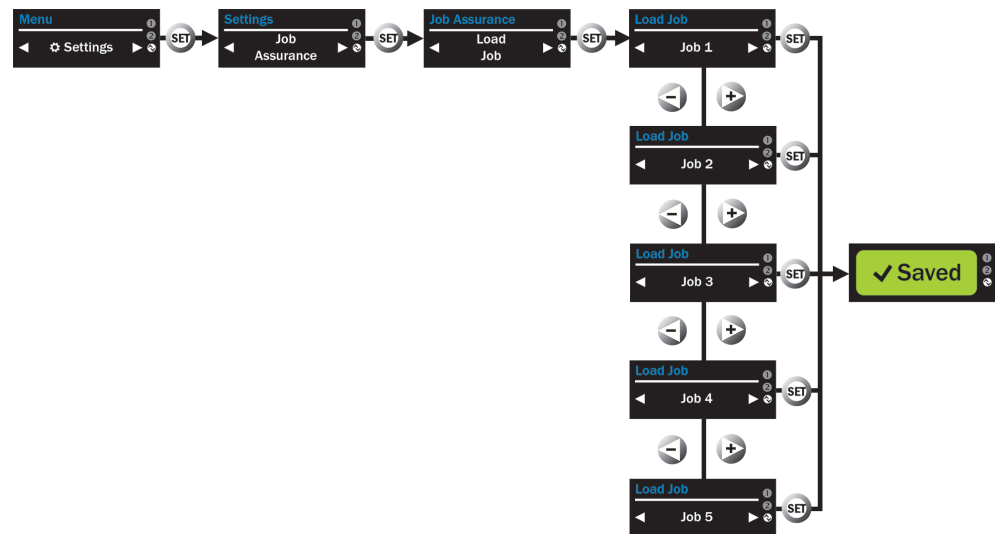

Figure 19: Load Job menu

In the Settings menu

1. Select the Job Assurance menu with the +/- pushbutton
2. Open the Job Assurance menu with the SET pushbutton
3. Select the Store Job or Load Job option with the +/- pushbutton
4. Confirm the selection with the SET pushbutton
5. Select the desired job with the +/- pushbutton
6. Confirm the selection with the SET pushbutton
 - The display shows SAVED

7.9 Additional settings via SOPAS



NOTICE

In this chapter, the operation of the sensor via the SOPAS configuration software is described.

The SOPAS ET software can be downloaded from the following link: <https://www.sick.com/de/en/sopas-engineering-tool-2018/p/p367244>

The driver for this product can be found at www.sick.com/AS30.

7.9.1 Setting up the sensor

The sensor can be set up with the wizard.

The alignment of the sensor (sensing distance, mounting angle) is optimized using the supplied alignment aid.

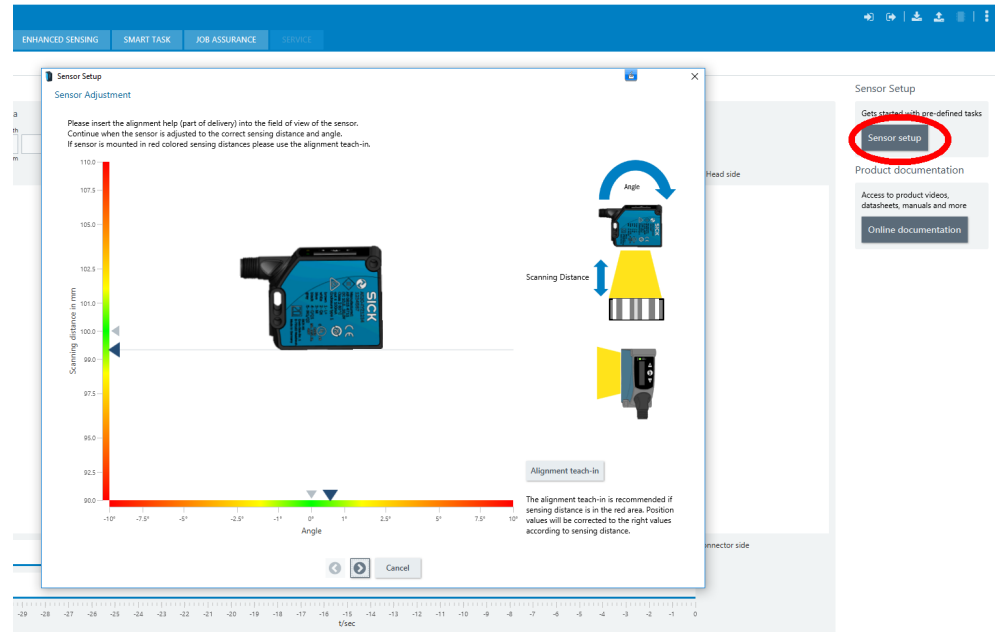

Figure 20: Sensor setup wizard

In SOPAS program

1. Start the wizard with the Sensor setup pushbutton
2. Follow the instructions from the wizard
 - Optimize the sensor alignment (sensing distance and mounting bracket).

7.9.2 Selecting the operating mode

The operating mode can be selected in the next step.

The AS30 Prime Edge sensor has 2 possible operating modes:

- **Edge Detection**
The edge selected in the Teach-In Edges menu is detected within tolerances values. The smoothing function of the sensor, which smooths position values over a 33 ms period, is automatically active. This ensures steady and stable edge guiding. The time interval for smoothing is configured via IO-Link and SOPAS.
- **Object Position**
The edge selected in the Teach-In Edges menu is positioned precisely. The smoothing function of the sensor is deactivated. Exact reproduction of object positioning is now possible.

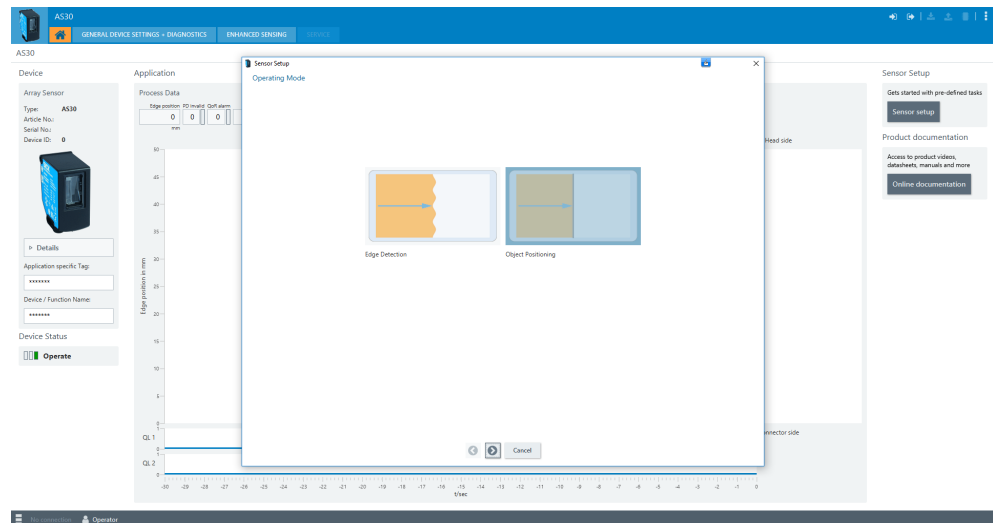

Figure 21: Operating mode setting

The wizard also asks for the reading direction, the background, the sensitivity, and the pin assignment configuration.

7.9.3 Other sensor settings and diagnostics

The sensor settings can be edited on the “General Device Settings + Diagnostics” tab. These are:

- **Background** Setting the sensor background between sensing, reflector and auto setting operation see "[Selection of reflector / sensing mode](#)", page 30
- **Reading direction**
The AS30 Prime Edge offers 2 reading directions for the sensor. The edge position values are outputted in the configured direction. The analog output on pin 2 switches accordingly. The options are
 - From the male connector to the head side (default)
 - From the head side to the male connector
 - Defined by input pin: Select this option to configure the reading direction via the input on pin 5.
- **Pin 2 configuration**
Pin 2 is the analog output of the detected edge and can be deactivated.
- **Pin 5 configuration**
Pin 5 can be configured either as an external input for smart task functions, an output for edge teach-in, a second digital switching output, an input for running a reflector teach or an input for changing the reading direction.
- **Other settings**
 - Activate/Deactivate emitted light
 - Set find-me function
 - Set IO-Link events
 - Set pushbutton lock

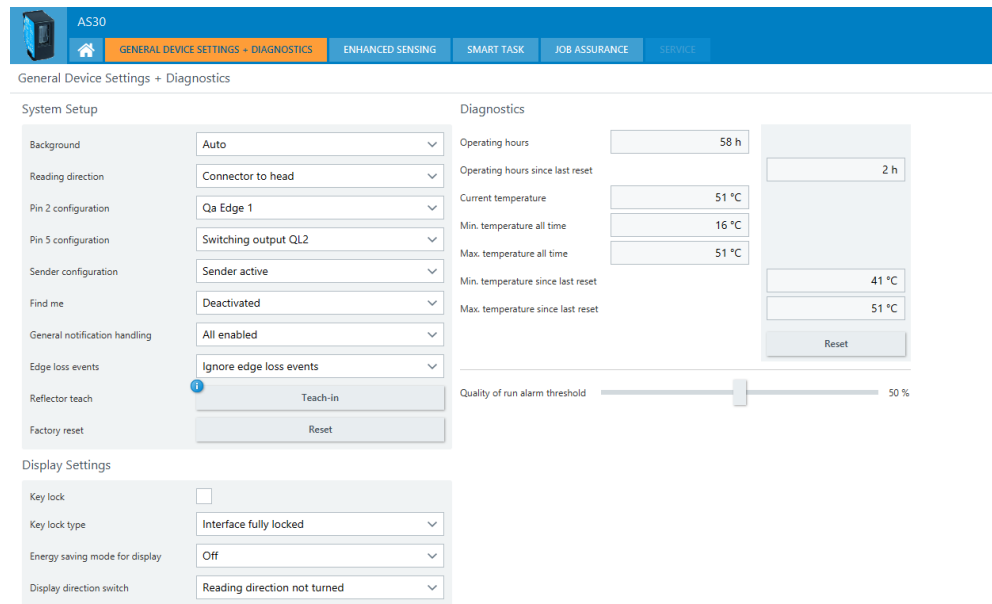

Figure 22: General Device Settings + Diagnostics tab

7.9.4 Enhanced Sensing

The Enhanced Sensing menu enables these functions:

- Executing edge teach-in
- Defining switching points or areas (similar to Area Teach-In)
- Configuring field of view
- Configuring the analog output

8 Troubleshooting

8.1 Possible errors during commissioning

LED indicator/fault pattern	Cause	Measures
Yellow Edge display LED flashing, "Short circuit" appears in display	<ul style="list-style-type: none"> - Short-circuit / Overcurrent - Sensor is not connected properly 	<ul style="list-style-type: none"> - Disconnect sensor from the power network - Check pin assignment - Reconnect sensor - Check the current at the switching output
"Target missing" appears in the display while the alignment aid is used	<ul style="list-style-type: none"> - Distance between the sensor and the object is too large or too small - Light emission (optics) is dirty. - Adjustment target missing 	<ul style="list-style-type: none"> - Clean sensor - Check the application conditions - Check adjustment target position. - Restart adjustment process.
"No edges found" appears in display	Programmed contrast or contrast difference is not sufficient for stable contrast detection.	<ul style="list-style-type: none"> - Clean sensor - Readjust the sensor - Check the application conditions - Restart teach process - Increase contrast difference (sensitivity)
Regular, unwanted teach-in processes	- Pin 5 configured as input for Edge Teach, but not activated	Deactivate pin 5 or connect to GND

8.2 Possible errors during operation

Table 5: Troubleshooting during operation

Display, error situation	Cause	Measure
No switching event any more	<ul style="list-style-type: none"> • Distance or angle to material not consistent • Sensor dirty • Target has changed 	<ul style="list-style-type: none"> • Clean sensor • Readjust sensor • Check parameter settings • Perform teach process again
Field of view does not correspond to the actual value	<ul style="list-style-type: none"> • Sensing distance incorrect • Reading direction incorrect 	Realign sensor
An edge is detected even though there is no object in the field of view	<ul style="list-style-type: none"> • Sensor dirty • In reflector mode: Reflector not taught-in 	<ul style="list-style-type: none"> • Clean sensor • Teach in reflector

9 Maintenance

9.1 Maintenance

During operation, the device works maintenance-free.

Depending on the assignment location, the following preventive maintenance tasks may be required for the device at regular intervals:

Table 6: Maintenance schedule

Maintenance work	Interval	Implementation
Clean housing and front screen	Cleaning interval depends on ambient conditions and climate	Specialist
Check screw connections and plug connectors	Every 6 months	Specialist

9.2 Cleaning the device

At regular intervals (e.g., weekly), check the light emission window and the housing of the device for dirt. This is especially relevant in harsh operating environments (dust, abrasion, damp, fingerprints, etc.). The lens of the light emission window must be kept clean and dry during operation.



NOTICE

Device damage due to improper cleaning!

Improper cleaning may result in device damage.

- Only use suitable cleaning agents.
- Never use sharp objects for cleaning.

Cleaning the light emission window



NOTICE

Damage to the light emission window!

Reduced reading performance due to scratches or streaks on the light emission window!

- ▶ Clean the light emission window only when wet.
- ▶ Use a mild cleaning agent that does not contain powder additives. Do not use aggressive cleaning agents, such as acetone, etc.
- ▶ Avoid any movements that could cause scratches or abrasions on the light emission window.
- ▶ Only use cleaning agents suitable for the lens material.



NOTE

Static charge may cause dust particles to stick to the light emission window. This effect can be avoided by using an anti-static glass cleaner in combination with the SICK lens cloth (can be obtained from www.sick.com).



NOTE

If the light emission window is scratched or damaged (cracked or broken), the device must be replaced. Contact SICK Service to arrange this.

Cleaning the housing

In order to ensure that the heat produced by the internal power loss is adequately dissipated, the housing surface must be kept clean.

10 Decommissioning

10.1 Disassembly and disposal

Disassembling the device

1. Switch off the supply voltage to the device.
2. Detach all connecting cables from the device.
3. If the device is being replaced, mark its position and alignment on the bracket or surroundings.
4. Detach the device from the bracket.

Disposing of the device

Any device which can no longer be used must be disposed of in an environmentally friendly manner in accordance with the applicable country-specific waste disposal regulations. As it is categorized as electronic waste, the device must never be disposed of with household waste!

10.2 Returning devices

- ▶ Do not dispatch devices to the SICK Service department without consultation.



NOTE

To enable efficient processing and allow us to determine the cause quickly, please include the following when making a return:

- Details of the contact person
 - Description of the application
 - Description of the fault that occurred
-

11 Technical data

11.1 General data

Table 7: Technical data

Attribute	Value	
Type designation	AS30- EBM314I220A00000C000 ZZ	AS30- EBM534I220A00000C000 ZZZ
Part number	1095577	1095578
Operating modes	Edge guidance (default) Object position	Edge guidance (default) Object position
Principle of operation	Sensing and reflector	Sensing and reflector
Sensing distance	25 mm	100 mm
Working range	20 mm ... 30 mm	90 mm ... 110 mm
Field of view	30 mm	50 mm
Smallest detectable object (MDO)	0.2 mm	0.5 mm
Light source	LED, white	LED, white
Wavelength	400 nm ... 700 nm	400 nm ... 700 nm
Light spot size	38.9 mm x 11.1 mm	62.5 mm x 13.2 mm
Linearity of position value	±2%	±2%
Repeatability	±0.03 mm	±0.05 mm
Resolution of the display or output value	1µm	1µm
Alignment aid	Display / IO-Link	Display / IO-Link
Teach-in function	Edge, Area	Edge, Area
Supply voltage	18-30V DC	
Ripple	≤5 V ¹	
Power consumption	< 3.1 W ²	
Switching output	Push / pull	
Switching output (voltage)	Push / Pull: HIGH = VS - 3 V / LOW ≤3 V	
Analog output	4 mA ... 20 mA	
Analog output resolution	12 bit	
Output rate of analog output	1 ms	
Output current I _{max.}	< 100 mA ³	
Initialization time	0.48 s	
Connection type	Male connector, M12, 5-pin ⁴	
Protection class	III	
Circuit protection	U _V connections, reverse polarity protected Output Q, short-circuit protected and overcurrent protected Electronic interference pulse suppression	
Enclosure rating	IP67	
Weight	250 g	
Housing material	Zinc die cast, powder-coated	
Ambient temperature, operation	-10 °C ... +55 °C	

Attribute	Value
Ambient temperature, storage	-25 °C ... +75 °C
Impact load	Acc. to IEC 60068
UL file no.	NRKH.E181493 (US) NRKH7.E181493 (Canada)
Communication interface	IO-Link V1.1
Communication interface detailed	COM3
Cycle time	min. 1 ms
Process data length	8 bytes

- 1 Must not fall below or exceed U_B tolerances.
- 2 Without load
- 3 Sum current of all outputs
- 4 Male connector $I_n = 2A$

11.2 Dimensional drawing

AS30 Prime Edge TW 25

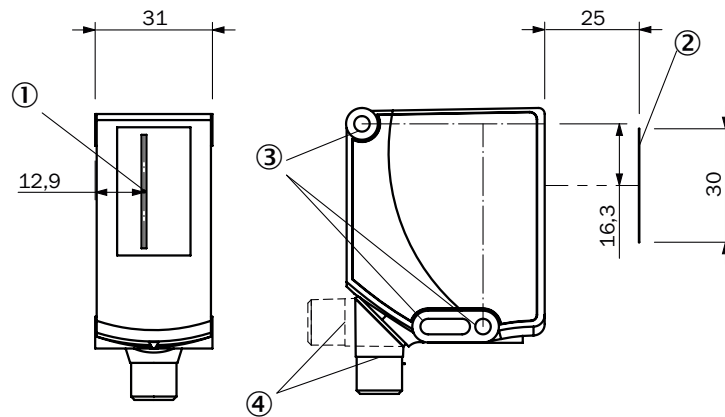

- ① Optical axis
- ② Field of view, 30 mm
- ③ Fixing hole, 4.1 mm
- ④ M12 device connection, can be rotated by 180°

AS30 Prime Edge TW 100

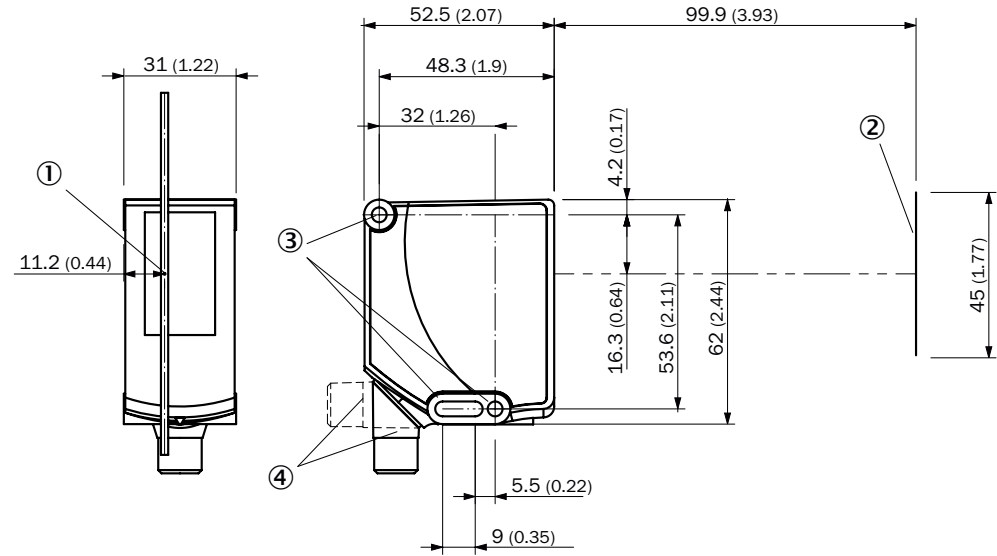

- ① Optical axis
- ② Field of view 50 mm
- ③ Fixing hole, 4.1 mm
- ④ M12 device connection, can be rotated by 180°

12 Accessories



NOTE

Accessories can be found on the online product page at:

▶ www.sick.com/AS30

13 Annex

13.1 EU declaration of conformity

The EU declaration of conformity and other certificates can be downloaded from the Internet at:

▶ www.sick.com/AS30

13.2 Certification according to UL60947-5-2



The AS30 Prime series array sensors are certified in accordance with UL60947-5-2 if they are supplied with power by LPS or Class 2 power supply units.

The certification is only valid with corresponding device identification on the type label of the respective device.

13.3 Licences

SICK uses open-source software. This software is licensed by the rights holders using the following licenses among others: the free licenses GNU General Public License (GPL Version2, GPL Version3) and GNU Lesser General Public License (LGPL), the MIT license, zLib license, and the licenses derived from the BSD license.

This program is provided for general use, but WITHOUT ANY WARRANTY OF ANY KIND. This warranty disclaimer also extends to the implicit assurance of marketability or suitability of the program for a particular purpose.

More details can be found in the GNU General Public License. View the complete license texts here: www.sick.com/licensetexts. Printed copies of the license texts are also available on request.

SICK uses open-source software. This software is licensed by the rights holders using the following licenses among others: the free licenses GNU General Public License (GPL Version2, GPL Version3) and GNU Lesser General Public License (LGPL), the MIT license, zLib license, and the licenses derived from the BSD license.

This program is provided for general use, but WITHOUT ANY WARRANTY OF ANY KIND. This warranty disclaimer also extends to the implicit assurance of marketability or suitability of the program for a particular purpose.

More details can be found in the GNU General Public License. For complete license texts, see www.sick.com/licensetexts. Printed copies of the license texts are also available on request.

Australia

Phone +61 (3) 9457 0600
1800 33 48 02 – tollfree
E-Mail sales@sick.com.au

Austria

Phone +43 (0) 2236 62288-0
E-Mail office@sick.at

Belgium/Luxembourg

Phone +32 (0) 2 466 55 66
E-Mail info@sick.be

Brazil

Phone +55 11 3215-4900
E-Mail comercial@sick.com.br

Canada

Phone +1 905.771.1444
E-Mail cs.canada@sick.com

Czech Republic

Phone +420 234 719 500
E-Mail sick@sick.cz

Chile

Phone +56 (2) 2274 7430
E-Mail chile@sick.com

China

Phone +86 20 2882 3600
E-Mail info.china@sick.net.cn

Denmark

Phone +45 45 82 64 00
E-Mail sick@sick.dk

Finland

Phone +358-9-25 15 800
E-Mail sick@sick.fi

France

Phone +33 1 64 62 35 00
E-Mail info@sick.fr

Germany

Phone +49 (0) 2 11 53 010
E-Mail info@sick.de

Greece

Phone +30 210 6825100
E-Mail office@sick.com.gr

Hong Kong

Phone +852 2153 6300
E-Mail ghk@sick.com.hk

Hungary

Phone +36 1 371 2680
E-Mail ertesites@sick.hu

India

Phone +91-22-6119 8900
E-Mail info@sick-india.com

Israel

Phone +972 97110 11
E-Mail info@sick-sensors.com

Italy

Phone +39 02 27 43 41
E-Mail info@sick.it

Japan

Phone +81 3 5309 2112
E-Mail support@sick.jp

Malaysia

Phone +603-8080 7425
E-Mail enquiry.my@sick.com

Mexico

Phone +52 (472) 748 9451
E-Mail mexico@sick.com

Netherlands

Phone +31 (0) 30 229 25 44
E-Mail info@sick.nl

New Zealand

Phone +64 9 415 0459
0800 222 278 – tollfree
E-Mail sales@sick.co.nz

Norway

Phone +47 67 81 50 00
E-Mail sick@sick.no

Poland

Phone +48 22 539 41 00
E-Mail info@sick.pl

Romania

Phone +40 356-17 11 20
E-Mail office@sick.ro

Russia

Phone +7 495 283 09 90
E-Mail info@sick.ru

Singapore

Phone +65 6744 3732
E-Mail sales.gsg@sick.com

Slovakia

Phone +421 482 901 201
E-Mail mail@sick-sk.sk

Slovenia

Phone +386 591 78849
E-Mail office@sick.si

South Africa

Phone +27 10 060 0550
E-Mail info@sickautomation.co.za

South Korea

Phone +82 2 786 6321/4
E-Mail infokorea@sick.com

Spain

Phone +34 93 480 31 00
E-Mail info@sick.es

Sweden

Phone +46 10 110 10 00
E-Mail info@sick.se

Switzerland

Phone +41 41 619 29 39
E-Mail contact@sick.ch

Taiwan

Phone +886-2-2375-6288
E-Mail sales@sick.com.tw

Thailand

Phone +66 2 645 0009
E-Mail marcom.th@sick.com

Turkey

Phone +90 (216) 528 50 00
E-Mail info@sick.com.tr

United Arab Emirates

Phone +971 (0) 4 88 65 878
E-Mail contact@sick.ae

United Kingdom

Phone +44 (0)17278 31121
E-Mail info@sick.co.uk

USA

Phone +1 800.325.7425
E-Mail info@sick.com

Vietnam

Phone +65 6744 3732
E-Mail sales.gsg@sick.com

Detailed addresses and further locations at www.sick.com