

# deTec2 Core IP69K

Safety light curtain

**SICK**  
Sensor Intelligence.



---

**Described product**

deTec2 Core IP69K

**Manufacturer**

SICK AG  
Erwin-Sick-Str. 1  
79183 Waldkirch  
Germany

**Legal information**

This work is protected by copyright. Any rights derived from the copyright shall be reserved for SICK AG. Reproduction of this document or parts of this document is only permissible within the limits of the legal determination of Copyright Law. Any modification, abridgment or translation of this document is prohibited without the express written permission of SICK AG.

The trademarks stated in this document are the property of their respective owner.

© SICK AG. All rights reserved.

**Original document**

This document is an original document of SICK AG.



## Contents

<b>1</b>	<b>About this document.....</b>	<b>6</b>
1.1	Scope.....	6
1.2	Target groups and structure of these operating instructions.....	6
1.3	Additional information.....	7
1.4	Symbols and document conventions.....	7
<b>2</b>	<b>Safety information.....</b>	<b>9</b>
2.1	General safety notes.....	9
2.2	Correct use.....	9
2.3	Requirements for the qualification of personnel.....	10
<b>3</b>	<b>Product description.....</b>	<b>11</b>
3.1	Structure and function.....	11
3.2	Product characteristics.....	13
3.2.1	Device overview.....	13
3.2.2	IP 69K protective housing.....	13
3.2.3	Automatic calibration of the protective field width.....	13
3.2.4	Status indicators.....	14
3.3	Example applications.....	16
<b>4</b>	<b>Project planning.....</b>	<b>18</b>
4.1	Manufacturer of the machine.....	18
4.2	Operator of the machine.....	18
4.3	Design.....	18
4.3.1	Scanning range and protective field width.....	19
4.3.2	Minimum distance from the hazardous point.....	19
4.3.3	Minimum distance to reflective surfaces.....	22
4.3.4	Protection against interference from systems in close proximity to each other.....	23
4.4	Integrating into the electrical control.....	23
4.4.1	Restart interlock.....	25
4.4.2	External device monitoring (EDM).....	26
4.4.3	Connection diagrams.....	27
4.5	Testing plan.....	27
4.5.1	Test rod check.....	28
4.5.2	Visual check of the machine and the protective device.....	30
<b>5</b>	<b>Mounting.....</b>	<b>31</b>
5.1	Safety.....	31
5.2	Unpacking.....	31
5.3	Installation.....	31
5.3.1	Mounting the reinforced stainless steel bracket.....	33
5.3.2	Mounting the stainless steel bracket.....	34
5.3.3	Mounting the stainless steel supporting bracket.....	35

<b>6</b>	<b>Electrical installation.....</b>	<b>37</b>
6.1	Safety.....	37
6.2	System connection (flying leads, 5-pin).....	38
<b>7</b>	<b>Commissioning.....</b>	<b>39</b>
7.1	Security.....	39
7.2	Overview.....	39
7.3	Switching on.....	40
7.4	Sender and receiver alignment.....	40
7.4.1	Aligning the sender and receiver.....	40
7.4.2	Alignment with the reinforced stainless steel bracket.....	41
7.4.3	Alignment with the stainless steel bracket.....	42
7.4.4	Indication of the alignment quality.....	43
7.5	Check during commissioning and modifications.....	44
<b>8</b>	<b>Operation.....</b>	<b>45</b>
8.1	Safety.....	45
8.2	Regular thorough check.....	45
<b>9</b>	<b>Maintenance.....</b>	<b>46</b>
9.1	Safety.....	46
9.2	Regular cleaning.....	46
9.3	Replacing the protective housing.....	47
9.4	Regular thorough check.....	48
<b>10</b>	<b>Troubleshooting.....</b>	<b>49</b>
10.1	Safety.....	49
10.2	Fault indicators.....	49
<b>11</b>	<b>Decommissioning.....</b>	<b>52</b>
11.1	Protection of the environment.....	52
11.2	Disposal.....	52
<b>12</b>	<b>Technical data.....</b>	<b>53</b>
12.1	Data sheet.....	53
12.2	Response time.....	56
12.3	power consumption.....	56
12.4	Table of weights.....	57
12.5	Dimensional drawings.....	58
<b>13</b>	<b>Ordering information.....</b>	<b>59</b>
13.1	Scope of delivery.....	59
13.2	Ordering information deTec2 Core IP69K.....	59
<b>14</b>	<b>Spare parts.....</b>	<b>60</b>
14.1	Protective housing.....	60

---

<b>15</b>	<b>Accessories.....</b>	<b>61</b>
15.1	Brackets.....	61
15.2	Connectivity.....	63
15.3	Deflector mirrors.....	63
15.3.1	Mounting.....	64
15.3.2	Change in scanning range using deflector mirrors.....	64
15.3.3	Deflector mirror PNS75 - ordering information.....	65
15.3.4	Deflector mirror PSN125 - ordering information.....	65
15.4	Mirror columns and device columns.....	65
15.4.1	Mirror columns.....	65
15.4.2	Device columns.....	66
15.5	Cleaning agent.....	66
15.6	Test rods.....	66
<b>16</b>	<b>Annex.....</b>	<b>67</b>
16.1	Compliance with EU directives.....	67
16.2	Checklist for initial commissioning and commissioning.....	68
16.3	Note on specified standards.....	69
<b>17</b>	<b>List of figures.....</b>	<b>70</b>
<b>18</b>	<b>List of tables.....</b>	<b>71</b>

## 1 About this document

These operating instructions contain information required during the life cycle of the safety light curtain.

These operating instructions are available to all those who work with the safety light curtain.

Please read these operating instructions carefully and make sure that you understand the content fully before working with the safety light curtain.

### 1.1 Scope

These operating instructions only apply to the deTec2 Core IP69K safety light curtain with the following type label entry in the “Operating Instructions” field:

- 8020650

This document is included with the following SICK part numbers (this document in all available language versions):

8020650

### 1.2 Target groups and structure of these operating instructions

These operating instructions are intended for the following target groups: Project developers (planners, developers, designers), installers, electricians, safety experts (e.g., CE authorized representatives, compliance officers, persons who test and approve the application), operators, and maintenance personnel.

The structure of these operating instructions is based on the life cycle phases of the safety light curtain: Project planning, mounting, electrical installation, commissioning, operation, and maintenance.

In many applications, the target groups are assigned as follows to the manufacturer and the organization operating the machine in which the safety light curtain is integrated:

Area of responsibility	Target group	Special chapters of these operating instructions <sup>1)</sup>
Manufacturer	Project developers (planners, developers, designers)	<a href="#">Project planning, page 18</a> <a href="#">Technical data, page 53</a> <a href="#">Accessories, page 61</a>
	Installers	<a href="#">Mounting, page 31</a>
	Electricians	<a href="#">Electrical installation, page 37</a>
	Safety experts	<a href="#">Project planning, page 18</a> <a href="#">Commissioning, page 39</a> <a href="#">Technical data, page 53</a> <a href="#">Checklist for initial commissioning and commissioning, page 68</a>
operating company	Operator	<a href="#">Operation, page 45</a> <a href="#">Troubleshooting, page 49</a>
	Maintenance personnel	<a href="#">Maintenance, page 46</a> <a href="#">Troubleshooting, page 49</a> <a href="#">Ordering information, page 59</a>

<sup>1)</sup> Chapters not listed here are intended for all target groups. All target groups must take into account the safety and warning instructions of the complete operating instructions!

In other applications, the operating organization is also the manufacturer of the equipment with the corresponding allocation of the target groups.

## 1.3 Additional information

[www.sick.com](http://www.sick.com)

The following information is available on the Internet:

- This document in other languages
- Data sheets and application examples
- CAD data of drawings and dimensional drawings
- Certificates (e.g. EU declaration of conformity)
- Guide for Safe Machinery Six steps to a safe machine

## 1.4 Symbols and document conventions

The following symbols and conventions are used in this document:

### Safety notes and other notes



#### DANGER

Indicates a situation presenting imminent danger, which will lead to death or serious injuries if not prevented.



#### WARNING

Indicates a situation presenting possible danger, which may lead to death or serious injuries if not prevented.



#### CAUTION

Indicates a situation presenting possible danger, which may lead to moderate or minor injuries if not prevented.



#### NOTICE

Indicates a situation presenting possible danger, which may lead to property damage if not prevented.



#### NOTE

Indicates useful tips and recommendations.

### Instructions to action

- ▶ The arrow denotes instructions to action.
- 1. The sequence of instructions for action is numbered.
- 2. Follow the order in which the numbered instructions are given.
- ✓ The check mark denotes the result of an instruction.

### LED symbols

These symbols indicate the status of an LED:

- The LED is off.
- ◐ The LED is flashing.
- The LED is illuminated continuously.

### Sender and receiver

These symbols indicate the sender and receiver of the device:

- ➡ The symbol indicates the sender.

 The symbol indicates the receiver.



## 2 Safety information

This chapter contains information on general safety for the safety light curtain.

More safety information about specific usage situations of the safety light curtain is available in the respective chapters.

### 2.1 General safety notes



#### **DANGER**

Hazard due to lack of effectiveness of the protective device

In the case of non-compliance, it is possible that the dangerous state of the machine may not be stopped or not stopped in a timely manner.

- ▶ Please read this document carefully and make sure that you understand the content fully before working with the device.
- ▶ Follow all safety notes in this document.

### 2.2 Correct use

The deTec2 Core IP69K safety light curtain is an electro-sensitive protective device (ESPE) and is suitable for the following applications:

- Hazardous point protection
- Access protection
- Hazardous area protection

The safety light curtain fulfills the requirements of the IP 69K enclosure rating.

The deTec2 Core IP69K safety light curtain must be only used within the limits of the prescribed and specified technical data and operating conditions at all times.

Any instance of improper use, incorrect modification, or manipulation of the deTec2 Core IP69K safety light curtain shall void any warranty provided by SICK AG; furthermore, SICK AG shall not accept any responsibility or liability for any resulting damage and consequential damage.

#### **Foreseeable misuse**



#### **DANGER**

Hazard due to lack of effectiveness of the protective device

Persons and parts of the body to be protected may not be recognized in case of non-observance.

The safety light curtain works as an indirect protective measure and cannot provide protection from parts thrown out nor from emitted radiation. Transparent objects are not detected.

- ▶ Only use the safety light curtain as an indirect protective measure.

Among others, the deTec2 Core IP69K safety light curtain is **not** suitable for the following applications:

- Outdoors
- Underwater
- In explosion-hazardous areas
- At altitudes over 3,000 m above sea level
- In environments with enhanced ionizing radiation

### 2.3 Requirements for the qualification of personnel

The safety light curtain must be configured, installed, connected, commissioned and serviced only by qualified safety personnel.

#### **Project planning**

For project planning, a person is considered competent when he/she has expertise and experience in the selection and use of protective devices on machines and is familiar with the relevant technical rules and national work safety regulations.

#### **Mechanical mounting**

For mechanical mounting, a person is considered competent when he/she has the expertise and experience in the relevant field and is sufficiently familiar with the application of the protective device on the machine that he/she can assess its operational safety status.

#### **Electrical installation**

For electrical installation, a person is considered competent when he/she has the expertise and experience in the relevant field and is sufficiently familiar with the application of the protective device on the machine that he/she can assess its operational safety status.

#### **Commissioning**

For commissioning, a person is considered competent when he/she has the expertise and experience in the relevant field and is sufficiently familiar with the application of the protective device on the machine that he/she can assess its operational safety status.

#### **Operation and maintenance**

For operation and maintenance, a person is considered competent when he/she has the expertise and experience in the relevant field and is sufficiently familiar with the application of the protective device on the machine and has been instructed by the machine operator in its operation.

An operator must clean the safety light curtain and carry out specific checks as instructed. More information for the operator of the machine: [see "Operation", page 45](#), [see "Regular cleaning", page 46](#).

## 3 Product description

This chapter provides information on the operation of the safety light curtain and shows examples of its range of use.

### 3.1 Structure and function

The deTec2 Core IP69K safety light curtain is an electro-sensitive protective device (ESPE) consisting of a sender and receiver.

A series of parallel infrared light beams form a protective field between sender and receiver that protects the hazardous area (hazardous point, access, and hazardous area protection). When one or more beams are completely interrupted, the safety light curtain reports the interruption in the light path to the secure output signal switching devices (OSSDs) by a signal change. The machine or its control must safely analyze the signals (for example using a safe control or safety relays) and stop the dangerous state.

Sender and receiver automatically synchronize themselves optically. An electrical connection between the two components is not required.

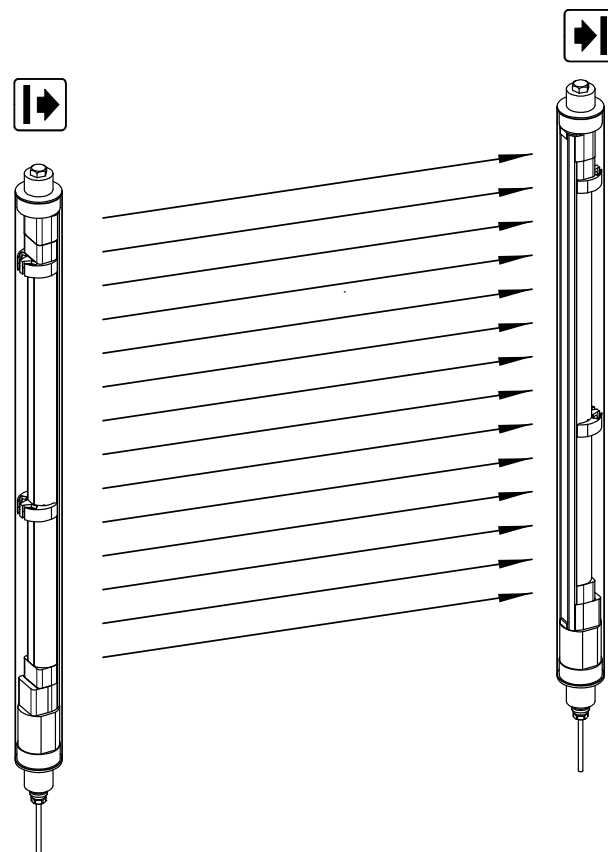

Figure 1: Sender and receiver

#### Protective field height

The protective field height indicates the range within which the test rod belonging to the safety light curtain is reliably detected. The size of the safety light curtain determines the protective field height.

### **Protective field width**

The protective field width is the dimension of the light path between sender and receiver. The maximum protective field width is limited by the scanning range.

### **Resolution**

The resolution describes the size of the smallest object detected by the safety light curtain in the protective field. The resolution corresponds to the diameter of the test rod belonging to the safety light curtain, which is reliably detected when in the protective field.

With the appropriate resolution, the safety light curtain provides finger and hand protection.

Information on protective field height, protective field width, and resolution: [see "Data sheet", page 53](#)

### **Interrelationship: Resolution and scanning range**

The safety light curtain is available with a resolution of 30 mm (0 m to 10 m).

The scanning range is the maximum protective field width. It depends on the resolution variant.

The scanning range is reduced by using deflector mirrors. More information: [see "Deflector mirrors", page 63](#).

## 3.2 Product characteristics

### 3.2.1 Device overview

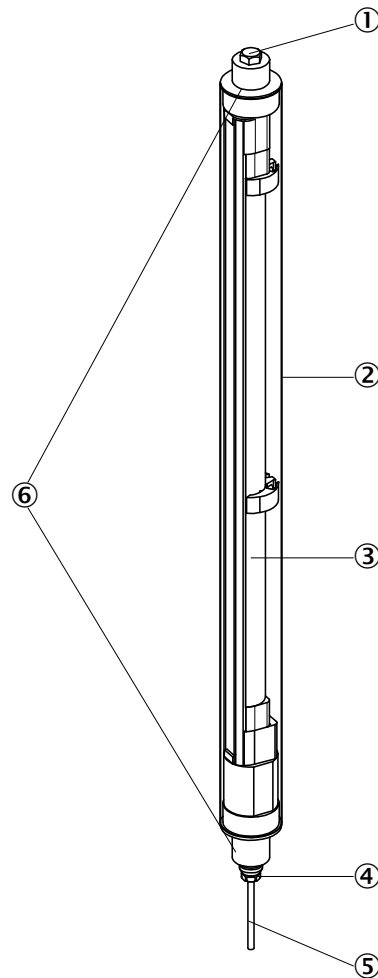

- ① Pressure equalizing element (aeration and ventilation membrane)
- ② IP 69K protective housing
- ③ Sender or receiver
- ④ Cable gland
- ⑤ Cable with flying leads
- ⑥ End caps

### 3.2.2 IP 69K protective housing

The safety light curtain is mounted in an IP 69K protective housing.

The protective housing is well resistant to standard cleaning agents, high-pressure cleaners with a water pressure up to 100 bar, and water temperatures up to 80° C. A pressure equalizing element (aeration and ventilation membrane) prevents plastic tubes being covered in condensation and liquids from entering the housing.

### 3.2.3 Automatic calibration of the protective field width

When switched on, the safety light curtain automatically calibrates to the protective field width.

3.2.4 Status indicators

The sender and receiver LEDs indicate the operational status of the safety light curtains.

Sender indicators

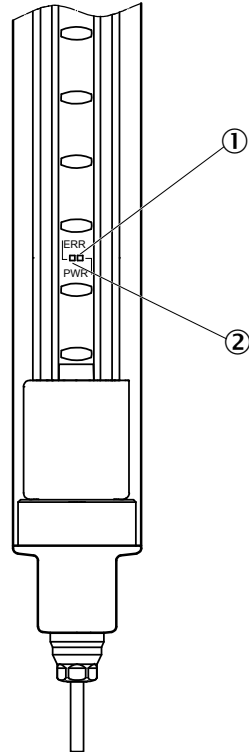

Figure 2: Sender indicators

Two light emitting diodes on the sender indicate the operational status:

No.	LED color	Advertisement	Labeling
①	Yellow	Status indicator	PWR
②	Red	Fault indicator	ERR

For a complete overview of the fault indicators: [see "Fault indicators", page 49](#).

Receiver indicators

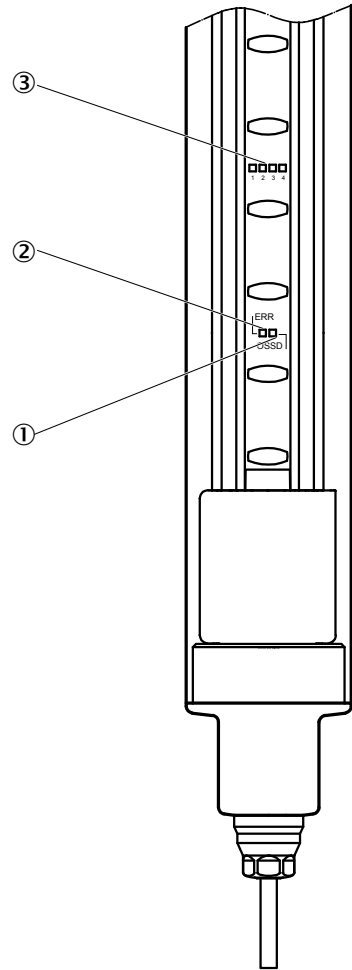

Figure 3: Receiver indicators

Six light emitting diodes on the receiver indicate the operational status:

No.	LED color	Advertisement	Labeling
①	Red/green	OSSD status	OSSD
②	Red	Fault indicator	ERR
③	Blue	Alignment quality	1, 2, 3, 4

The blue alignment quality light emitting diodes in combination with the red flashing ERR LED also denote faults.

For a complete overview of the fault indicators: [see "Fault indicators", page 49.](#)

### 3.3 Example applications

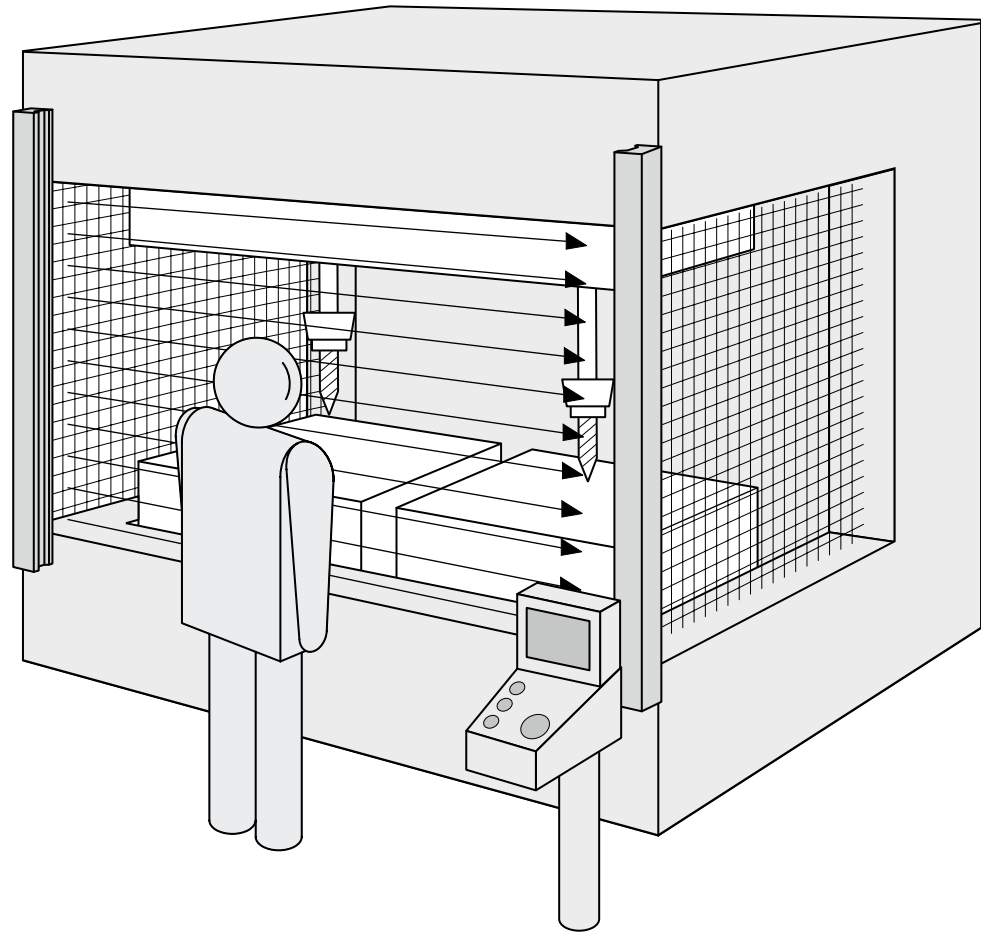

Figure 4: Hazardous point protection

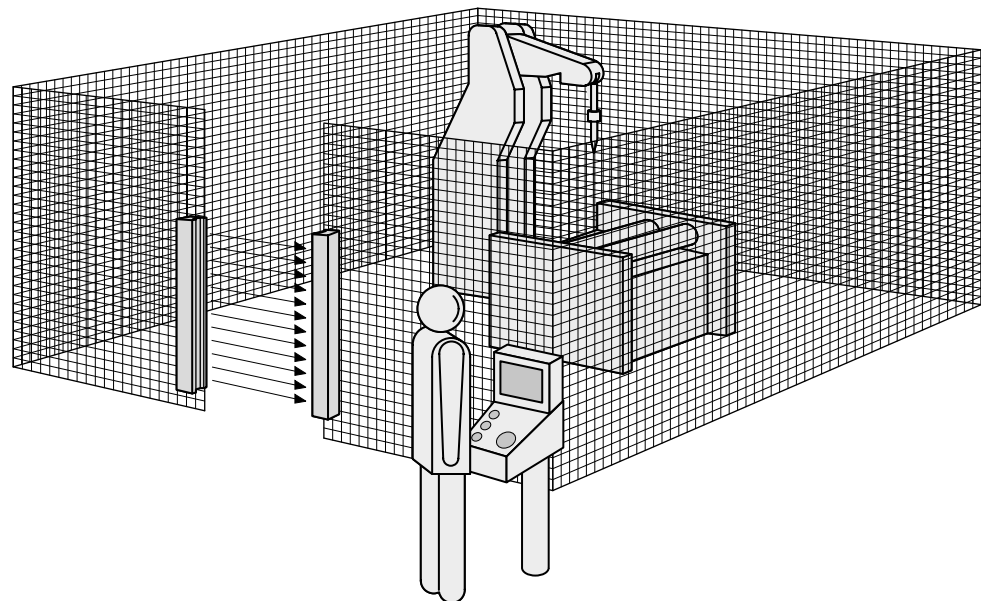

Figure 5: Access protection



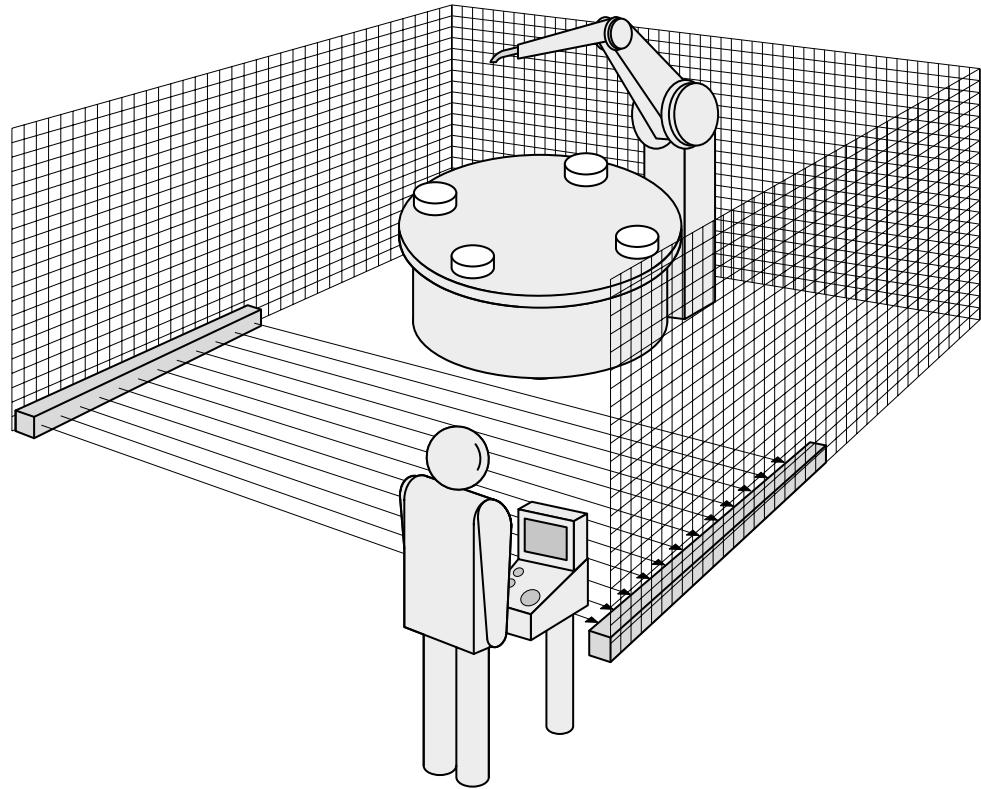

Figure 6: Hazardous area protection

### 4 Project planning

This chapter includes important information about the proper integration of the safety light curtain in machines for planners, developers and designers.

#### 4.1 Manufacturer of the machine

---



##### **DANGER**

Hazard due to lack of effectiveness of the protective device

Persons and parts of the body to be protected may not be recognized in case of non-observance.

- ▶ Conduct a risk assessment and check whether additional protective measures are required.
  - ▶ Comply with the applicable national regulations derived from the application (e.g., work safety regulations, safety rules, or other relevant safety guidelines).
  - ▶ Do not combine the components of the safety light curtain with components from other safety light curtains.
  - ▶ Apart from for the procedures described in this document, the components of the safety light curtain must not be opened.
  - ▶ The components of the safety light curtain must not be tampered with or changed.
  - ▶ Do not carry out any repairs on the device components. Improper repair of the protective device can lead to a loss of the protective function.
- 

#### 4.2 Operator of the machine

---



##### **DANGER**

Hazard due to lack of effectiveness of the protective device

Persons and parts of the body to be protected may not be recognized in case of non-observance.

- ▶ Changes to the electrical integration of the safety light curtain in the machine control and changes to the mechanical installation of the safety light curtain require another risk assessment. The results of this risk assessment may require the operator of the machine to meet the obligations of a manufacturer.
  - ▶ Apart from the procedures described in this document, the components of the safety light curtain must not be opened.
  - ▶ The components of the safety light curtain must not be tampered with or changed.
  - ▶ Do not carry out any repairs on the device components. Improper repair of the protective device can lead to a loss of the protective function.
- 

#### 4.3 Design

This chapter contains important information about the design.

Information about the individual steps for mounting the device: [see "Mounting", page 31.](#)

**DANGER**

Hazard due to lack of effectiveness of the protective device

Persons and parts of the body to be protected may not be recognized in case of non-observance.

- ▶ Make sure that the following construction requirements are met so that the safety light curtain can fulfill its protective function.
  - Sender and receiver must be arranged such that persons or parts of the body are reliably detected when they enter the hazardous area.
  - Reaching under, over, and around as well as moving the safety light curtain must be prevented.
  - Check whether additional safety measures (e.g. restart interlocking) are necessary when it is possible for people to be located between the protection system and the danger point without being detected.

### 4.3.1 Scanning range and protective field width

#### Scanning range

The scanning range limits the maximum protective field width. The protective field width cannot change during operation, see ["Technical data", page 53](#).

The scanning range is reduced by using deflector mirrors, see ["Deflector mirrors", page 63](#).

#### Protective field width

The protective field width is the dimension of the light path between sender and receiver.

The protective field width is automatically calibrated when the safety light curtain is switched on during initialization and must not be changed during operation.

**DANGER**

Hazard due to lack of effectiveness of the protective device

Persons and parts of the body to be protected may not be recognized in case of non-observance.

- ▶ The safety light curtain can only be mounted on machines on which the protective field width does not change when the safety light curtain is switched on.

### 4.3.2 Minimum distance from the hazardous point

A minimum distance must be maintained between the safety light curtain and the hazardous point. This distance is required to prevent a person or part of their body from reaching the hazardous point before the end of the machine's dangerous state.

**DANGER**

Minimum distance from the hazardous point is too small

The dangerous state of the machine may not be stopped or not be stopped in a timely manner due to a minimum distance that is too small.

- ▶ Calculate the minimum distances for the machine in which the safety light curtain is integrated.
- ▶ When mounting the safety light curtain, observe the minimum distance.

**Calculate minimum distance**

The calculation of the minimum distance is based on international and national standards and statutory requirements applicable at the place of installation of the machine.

If the minimum distance is calculated according to ISO 13855, then it depends on the following points:

- Machine stopping time (time interval between triggering the sensor function and the end of the dangerous state of the machine)
- Response time of the protective device, see "Response time", page 56
- Reach or approach speed of the person
- Resolution (detection capability) of the safety light curtain
- Type of approach: orthogonal (at right angles) or parallel
- Parameters specified based on the application

For the USA (scope of OSHA and ANSI), different regulations may apply, e.g.:

- a) Laws: Code of Federal Regulations, Title 29 (CFR29) Part 1910.217
- b) Standards: ANSI B11.19



**NOTE**

Additional information is available in the ISO 13855 standard and in the Guide for Safe Machinery.



**NOTE**

SICK offers a stopping/run-down time measurement service in many countries.

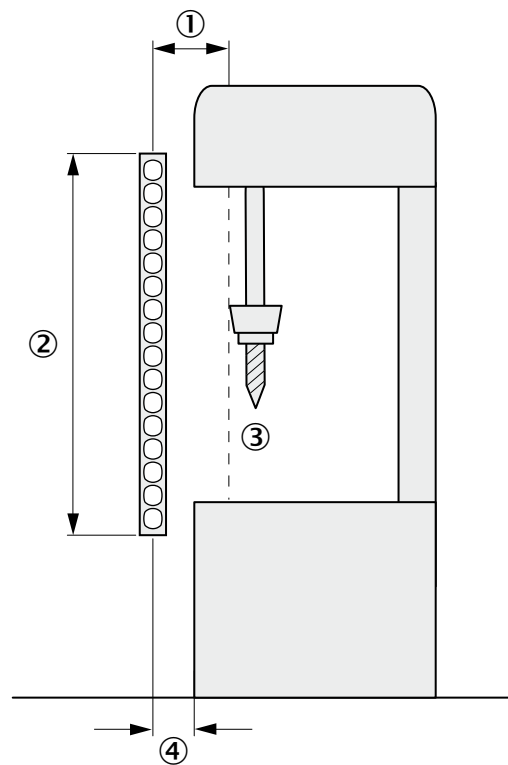

Figure 7: Minimum distance to hazardous point for orthogonal (right-angled) approach to protective field

- ① Minimum distance S
- ② Protective field height
- ③ Hazardous point

- ④ Depending on the application and distance, persons must be prevented from standing behind the protective device.

#### Calculation example of the minimum distance S according to ISO 13855

The example shows the calculation of the minimum distance for an orthogonal (right-angled) approach to the protective field. A different calculation may be required depending on the application and the ambient conditions (e.g., for a protective field parallel to or at any angle to the direction of approach or an indirect approach).

- First, calculate S using the following formula:  

$$S = 2,000 \text{ mm/s} \times T + 8 \times (d - 14 \text{ mm})$$
 Where:
  - S = minimum distance in millimeters (mm)
  - T = machine stopping time + response time of the protective device after interruption in the light path in seconds (s)
  - d = resolution of the safety light curtain in millimeters (mm)
 The reach or approach speed is already included in the formula.
- If the result S is  $\leq 500$  mm, then use the determined value as the minimum distance.
- If the result S is  $> 500$  mm, then recalculate S as follows:  

$$S = 1,600 \text{ mm/s} \times T + 8 \times (d - 14 \text{ mm})$$
- If the new value S is  $> 500$  mm, then use the newly determined value as the minimum distance.
- If the new value S is  $\leq 500$  mm, then use 500 mm.

#### Example calculation

Machine stopping time = 290 ms

Response time after interruption of the light path = 30 ms

Resolution of the safety light curtain = 14 mm

$T = 290 \text{ ms} + 30 \text{ ms} = 320 \text{ ms} = 0.32 \text{ s}$

$S = 2,000 \text{ mm/s} \times 0.32 \text{ s} + 8 \times (14 \text{ mm} - 14 \text{ mm}) = 640 \text{ mm}$

$S > 500$  mm, therefore:

$S = 1,600 \text{ mm/s} \times 0.32 \text{ s} + 8 \times (14 \text{ mm} - 14 \text{ mm}) = 512 \text{ mm}$

#### Taking reaching over into account

If access to the hazardous area by reaching over a protective field cannot be prevented, the height of the protective field and minimum distance of the ESPE must be determined. This is done by comparing the calculated values based on the possible detection of limbs or body parts with the values resulting from reaching over the protective field. The greater value resulting from this comparison must be used.



Figure 8: Representation of the accessibility of electro-sensitive protective device by reaching over. Left: Protective field that cannot be reached over. Right: Protective field that can be reached over.

4.3.3 Minimum distance to reflective surfaces



**DANGER**

Hazard due to lack of effectiveness of the protective device

Reflective surfaces and dispersive media can prevent persons or parts of the body to be protected from being properly reflected and, therefore, remain undetected.

- ▶ Make sure that all reflective surfaces and objects maintain a minimum distance from the protective field.
- ▶ Make sure that no dispersive media (e.g., dust, fog, or smoke) are within the calculated minimum distance from the protective field.

The light beams from the sender may be deflected by reflective surfaces and dispersive media. This may prevent an object from being detected.

Therefore, all reflective surfaces and objects (e.g. material bins, machine table, etc.) must maintain a minimum distance (a) from the protective field. This minimum distance (a) must be maintained on all sides of the protective field. This applies in horizontal, vertical and diagonal directions as well as at the end of the safety light curtain. The same area must be free of dispersive media (e.g., dust, fog, or smoke).

The minimum distance (a) depends on the distance (D) between sender and receiver (protective field width).

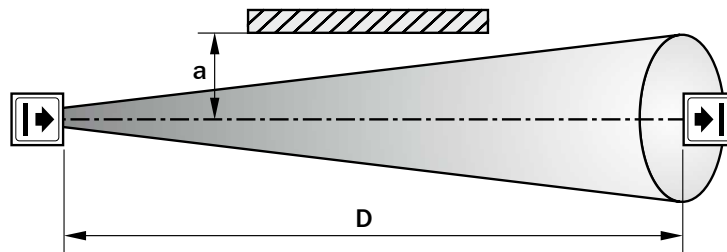

Figure 9: Minimum distance to reflective surfaces

**How to determine the minimum distance from reflective surfaces:**

1. Determine the distance between sender and receiver D in meters (m)
2. Read the minimum distance a in millimeters (mm) in the graph or calculate it based on the respective formula from [table 1](#):

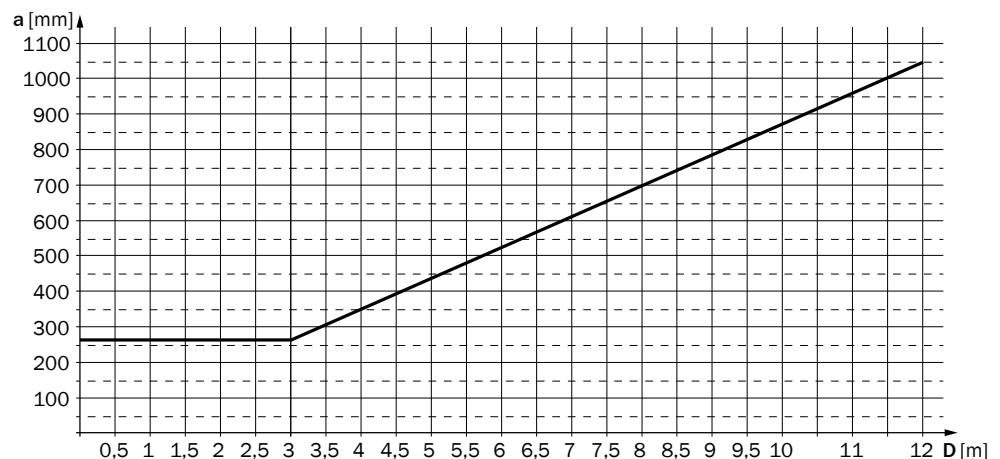

Figure 10: Graph, minimum distance from reflective surfaces

Table 1: Formula for calculating the minimum distance for reflective surfaces

Distance between sender and receiver D in m	Calculating the minimum distance for reflective surfaces a in mm
$D \leq 3$ m	$a = 262$ mm
$D > 3$ m	$a = \tan(5^\circ) \times 1,000 \text{ mm/m} \times D = 87.49 \times 1 \text{ mm/m} \times D$

#### 4.3.4 Protection against interference from systems in close proximity to each other



##### DANGER

Hazard due to lack of effectiveness of the protective device

Systems of safety light curtains that operate in close proximity to each other can interfere with each other.

- Use appropriate measures to prevent systems in close proximity from interfering with each other.

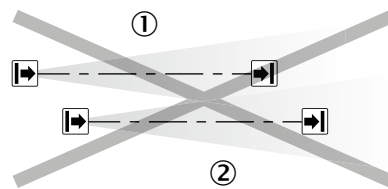

Figure 11: Preventing mutual interference from system ① and system ②

The infrared light beams of the sender of system ① can interfere with the receiver of system ②. This can disrupt the protective function of system ②. This would mean that the operator is at risk.

Avoid such installation situations or take appropriate action, e.g., install optically opaque partitions or reverse the direction of transmission of a system.

##### Reversed direction of transmission

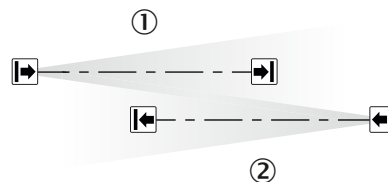

Figure 12: Trouble-free operation due to reversed direction of transmission of system ① and system ②

In the figure, the direction of transmission of systems in close proximity to each other is reversed. System ② is not affected by the beams of system ①.

## 4.4 Integrating into the electrical control

This chapter contains important information about integration in the electrical control. Information about the individual steps for electrical installation of the device: [see "Electrical installation", page 37](#).

##### Requirements for use

The output signals of the protective device must be analyzed by downstream controllers in such a way that the dangerous state of the machine is ended safely. Depending on the safety concept, the signal is analyzed by, e.g., safety relays or a safety controller.

**DANGER**

Hazard due to lack of effectiveness of the protective device

In the case of non-compliance, it is possible that the dangerous state of the machine may not be stopped or not stopped in a timely manner.

- ▶ Make sure that the following control and electrical requirements are met so that the safety light curtain can fulfill its protective function.

- It must be possible to electrically influence the control of the machine.
- The electrical control of the machine must meet the requirements of IEC 60204-1.
- A restart interlock must be implemented depending on applicable national regulations or required reliability of the safety function. Because the safety light curtain does not have this function, it must be implemented in the external control if required.
- When using a safety controller, different signal levels of both OSSDs must be detected depending on applicable national regulations or required reliability of the safety function. The maximum discrepancy time tolerated by the control must be selected according to the application.
- The OSSD1 and OSSD2 output signals must not be connected to each other.
- In the machine controller, the signals of both OSSDs must be processed separately.

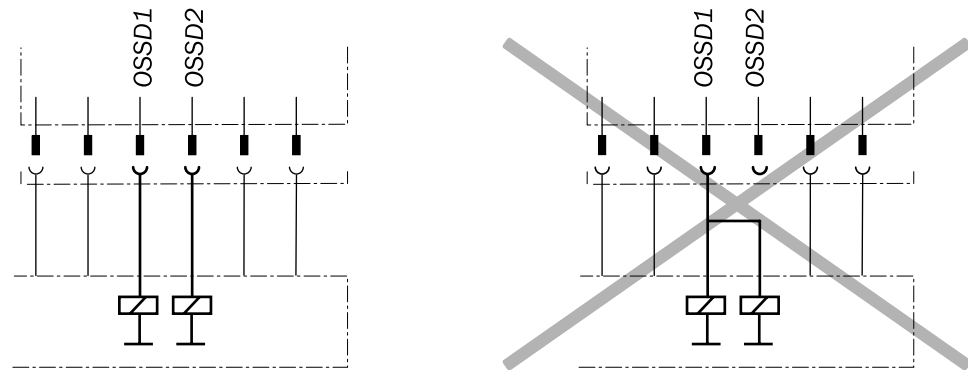

Figure 13: Dual-channel and isolated connection of OSSD1 and OSSD2

- The machine must switch to the safe state at any time if at least one of the two OSSDs switches to the OFF state.
- Prevent the formation of a potential difference between the load and the protective device. If you connect loads to the OSSDs (safety outputs) that then also switch if controlled with negative voltage (e.g., electro-mechanical contactor without reverse polarity protection diode), you must connect the 0 V connections of these loads and those of the corresponding protective device individually and directly to the same 0 V terminal strip. In the event of a fault, this is the only way to ensure that there can be no potential difference between the 0 V connections of the loads and those of the corresponding protective device.



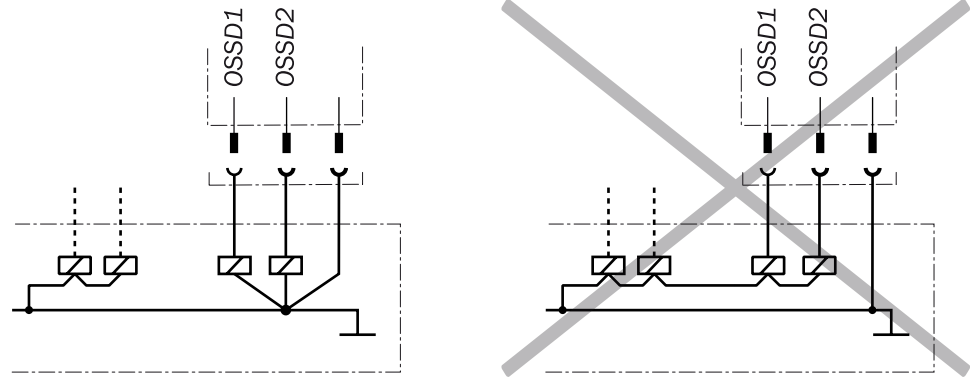

Figure 14: No potential difference between load and protective device



#### DANGER

Hazard due to lack of effectiveness of the protective device

In the case of non-compliance, it is possible that the dangerous state of the machine may not be stopped or not stopped in a timely manner.

Downstream contactors must be positively guided and monitored depending on applicable national regulations or required reliability of the safety function.

- ▶ Make sure that downstream contactors are monitored (external device monitoring, EDM).
- ▶ Because the safety light curtain does not have integrated external device monitoring, this must be implemented in the external control, if required.

#### Requirements for the electrical control of the machine

The two outputs are short-circuit protected to 24 V DC and 0 V. When the protective field is clear, the OSSDs are in the ON state and the signal level is HIGH (non-isolated). In the event of an interruption in the light path or device fault, the OSSDs are in the OFF state and the signal level is LOW (above 1.5 kΩ to 0 V).

The safety light curtain complies with the rules for electromagnetic compatibility (EMC) for the industrial sector (Radio Safety Class A). Radio interference cannot be ruled out when used in residential areas.



#### DANGER

Hazard due to lack of effectiveness of the protective device

In the case of non-compliance, it is possible that the dangerous state of the machine may not be stopped or not stopped in a timely manner.

- ▶ Make sure that the following control and electrical requirements are met so that the safety light curtain can fulfill its protective function.
  - The external voltage supply of the safety light curtain must be capable of jumpering a brief power failure of 20 ms as specified in IEC 60204-1.
  - The power supply unit must ensure safe isolation according to IEC 61140 (SELV/PELV). Suitable power supply units are available as accessories from SICK, see "Accessories", page 61.

#### 4.4.1 Restart interlock

Depending on the regulations which apply at the place of installation, a restart interlock may be required.

The restart interlock prevents the machine from automatically starting up, for example after a protective device has responded while the machine is operating or after changing the machine's operating mode.

Before the machine can be restarted, the operator must reset the restart interlock.

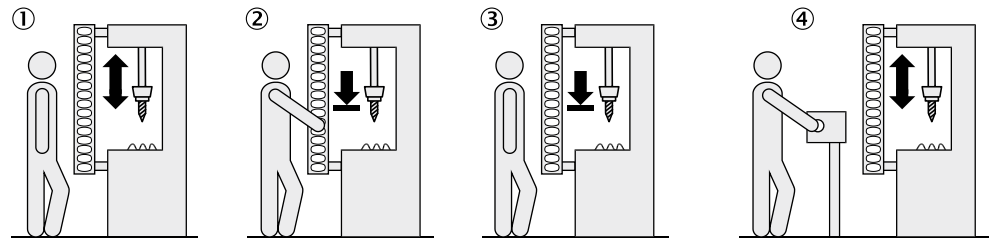

Figure 15: Schematic representation of operation with restart interlock

The dangerous state of the machine ① is brought to an end if the light path is interrupted ② and is not re-enabled ③ until the operator presses the reset pushbutton located outside the hazardous area ④. The machine can then be restarted.

Depending on the applicable national regulations, there must be a restart interlock if a person can stand behind the protective field. Observe IEC 60204-1.

The safety light curtain does not have an internal restart interlock. If required, a restart interlock must therefore be implemented externally via the circuitry or the control, e.g., in connection with the SICK switching amplifier UE48-20S/UE48-30S.

### 4.4.2 External device monitoring (EDM)

The external switching elements (external device monitoring, EDM) must be inspected in line with the regulations which apply at the place of installation or the required reliability of the safety function.

The external device monitoring (EDM) monitors the status of downstream contactors.

In order to use the external device monitoring, positively guided contactors must be used to switch off the machine. If the auxiliary contacts of the positively guided contactors are connected to the external device monitoring, the external device monitoring checks whether the contactors drop off when the OSSDs are switched off.



#### NOTE

Because the safety light curtain does not have integrated external device monitoring, this must be implemented in the external control, if required.

### 4.4.3 Connection diagrams

#### Connection diagram for UE48-20S with restart interlock and external device monitoring

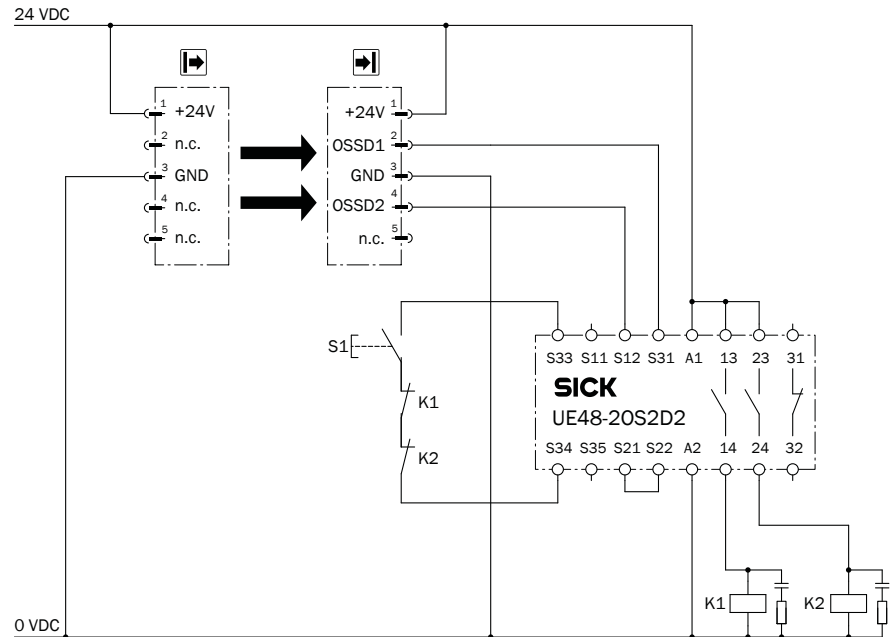

Figure 16: Connection diagram for UE48-20S with restart interlock and external device monitoring

The safety light curtain can be connected to the UE48-20S switching amplifiers. It is operated with restart interlock and external device monitoring.

#### Functionality

When the protective field is clear, the OSSD1 and OSSD2 outputs carry voltage. The system can be switched on when K1 and K2 are in the de-energized position. Pressing the S1 button switches on the UE48 switching amplifier. Contacts 13-14 and 23-24 of the UE48 activate the K1 and K2 contactors.

When the protective field is interrupted, the OSSD1 and OSSD2 outputs carry no voltage. The UE48 switches off and K1, K2 are deactivated.

#### Fault analysis

Failure of K1 and K2 does not cause the loss of the shut-down function. Cross-circuits and short-circuits of the OSSD1 and OSSD2 outputs are recognized and lead to the locking state. It is recognized if the K1 or K2 contactors do not de-energize.

## 4.5 Testing plan

The manufacturer of the machine and the operating entity must define all required checks. The definition must be based on the application conditions and the risk assessment and must be documented in a traceable manner.

- ▶ When defining the check, please note the following:
  - Define the type and execution of the check.
  - Define the frequency of the check.
  - Notify the machine operators of the check and instruct them accordingly.

The following checks are often defined in connection with a protective device:

- Check during commissioning and modifications
- Regular thorough check

### Check during commissioning and modifications

The check must detect if it is possible to enter the hazardous area without being detected.

The following points are often helpful for the definition of the check:

- Does the check have to be completed by qualified safety personnel?
  - Can the check be completed by specially qualified and authorized personnel?
  - Does the check have to be documented in a traceable manner?
  - Can the check be carried out according to a check list (see "[Checklist for initial commissioning and commissioning](#)", page 68)?
  - Do the machine operators know the function of the protective device?
  - Have the machine operators been trained to work on the machine?
  - Have the machine operators been notified about modifications on the machine?
  - Does the hazardous area to be secured have to be checked with a test rod, see "[Test rod check](#)", page 28?
- ▶ Define all guidelines for the check.

### Regular thorough check

The check must detect if it is possible to enter the hazardous area without being detected. Such possibilities may exist due to modifications, manipulations or external influences.

The following points are often helpful for the definition of the check:

- Which check must be carried out and how is it carried out?
    - [Test rod check](#), page 28
    - [Visual check of the machine and the protective device](#), page 30
  - How often does the check have to be carried out?
  - Do the machine operators have to be notified of the check and do they need to be instructed accordingly?
- ▶ Define all guidelines for the check.

#### 4.5.1 Test rod check

##### Overview

The rod test check is used to check whether the hazardous point is only accessible via the protective field of the safety light curtain and whether the protective device is able to identify each time the hazardous point is approached.

The test is carried out with an opaque test rod whose diameter corresponds to the resolution of the safety light curtain.

##### Important information

---



##### DANGER

Use of incorrect test rods

Persons or parts of the body to be protected may not be detected in operation.

- ▶ Only use the included test rod with the diameter specified on the type label of the safety light curtain.
  - ▶ Do not use any test rods with a similar or the same diameter of other safety light curtains.
-

**DANGER**

Hazard due to unexpected starting of the machine

- ▶ Make sure that the dangerous state of the machine is and remains switched off during the check.
- ▶ Make sure that the outputs of the safety light curtain have no effect on the machine during the check of the components.

**DANGER**

Hazard due to lack of effectiveness of the protective device

Persons and parts of the body to be protected may not be recognized in case of non-observance.

Do not operate the machine if the OSSD LED lights up green during the test!

- ▶ If the OSSD LED lights up green during the test even if only briefly, work must stop at the machine.
- ▶ In this case, the mounting and electrical installation of the safety light curtain must be checked by qualified safety personnel.

**Prerequisites**

- The OSSD LED lights up green.

**Approach**

1. Move the test rod slowly through the protective field to be protected (e.g., machine opening as indicated by the arrow, [see figure 17, page 29](#)).
2. Watch the OSSD LED on the receiver during the check. The OSSD LED on the receiver should continuously light up red. The OSSD LED must not illuminate green.

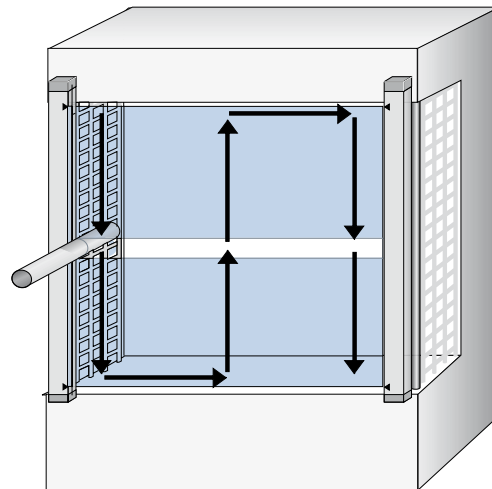

Figure 17: Test rod check: Step 1

3. Then, guide the test rod along the edges of the area to be protected as indicated by the arrow, [see figure 18](#).
4. Watch the OSSD LED on the receiver during the check. The OSSD LED on the receiver should continuously light up red. The OSSD LED must not illuminate green.

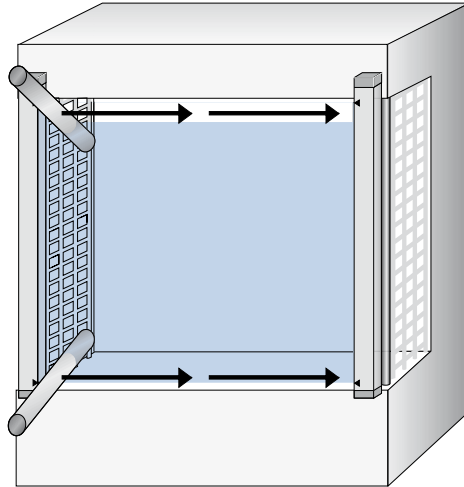

Figure 18: Test rod check: Step 2

5. If one or more deflector mirrors are used, then the test rod should also be guided slowly through the area to be protected directly in front of the deflector mirrors.
6. Watch the OSSD LED on the receiver during the check. The OSSD LED on the receiver should continuously light up red. The OSSD LED must not illuminate green.

### 4.5.2 Visual check of the machine and the protective device

The following points are often helpful for the definition of the check:

- Has the machine been retrofitted?
- Have machine parts been removed?
- Have modifications been made to the surroundings of the machine?
- Have the protective device or its parts been dismantled?
- Is it possible to enter the hazardous area without being detected?
- Is the protective device damaged?
- Is the protective device severely contaminated?
- Is the front screen contaminated, scratched or destroyed?
- Are there any damaged cables or open cable ends?

If one of the points applies, the machine should be shut down immediately. In this case, the machine and the protective device must be checked by appropriately qualified safety personnel.

## 5 Mounting

### 5.1 Safety

For information on the requirements for properly mounting the safety light curtain, see ["Design", page 18](#).



#### **DANGER**

Dangerous state of the machine

- ▶ Make sure that the dangerous state of the machine is (and remains) switched off during mounting, electrical installation, and commissioning.
- ▶ Make sure that the outputs of the safety light curtain do not affect the machine during mounting, electrical installation, and commissioning.



#### **DANGER**

Hazard due to lack of effectiveness of the protective device

If unsuitable brackets are used or if subjected to excessive vibrations, the device may become detached or damaged.

Persons and parts of the body to be protected may not be recognized in case of non-observance.

- ▶ Only use SICK-approved brackets for mounting.
- ▶ Take appropriate measures for vibration damping if vibration and shock specifications exceed the values and test conditions specified in the data sheet.



#### **NOTE**

The IP 69K protective housing can be replaced if damaged.



#### **NOTE**

Mount the device in the following order.

### 5.2 Unpacking

#### **Approach**

1. Check the components for completeness and the integrity of all parts.
2. Do not completely remove the protective film from the plastic tubes.
3. Clean the plastic tubes prior to first commissioning.
4. Please contact your respective SICK subsidiary should you have any complaints.

#### **Further topics**

- ["Scope of delivery", page 59](#)

### 5.3 Installation

The sender and receiver can be mounted with rotatable stainless steel brackets:

- Reinforced stainless steel bracket, rotatable
- Stainless steel bracket, rotatable
- Stainless steel supporting bracket



### DANGER

Hazard due to lack of effectiveness of the protective device

Persons or parts of the body to be protected may not be recognized or not recognized in time in case of non-observance.

- ▶ It is vital that you observe the minimum distances calculated for your machine: see "[Minimum distance from the hazardous point](#)", page 19, see "[Minimum distance to reflective surfaces](#)", page 22.
  - ▶ Mount the safety light curtain such that it is not possible to reach below, above, around, or behind the safety light curtain, and that the light curtain cannot be repositioned.
- 



### DANGER

Hazard due to lack of effectiveness of the protective device

Persons and parts of the body to be protected may not be recognized in case of non-observance.

- ▶ The safety light curtain can only be mounted on machines on which the protective field width does not change when the safety light curtain is switched on.
- 



### NOTE

- ▶ Read this section completely before mounting the brackets.
  - ▶ Read the information on aligning the sender and receiver, "[Sender and receiver alignment](#)", page 40
- 

### Mounting instructions

---



### DANGER

Hazard due to lack of effectiveness of the protective device

Persons and parts of the body to be protected may not be recognized in case of non-observance.

- ▶ The end with the cable connection must point in the same direction for the sender and receiver.
-



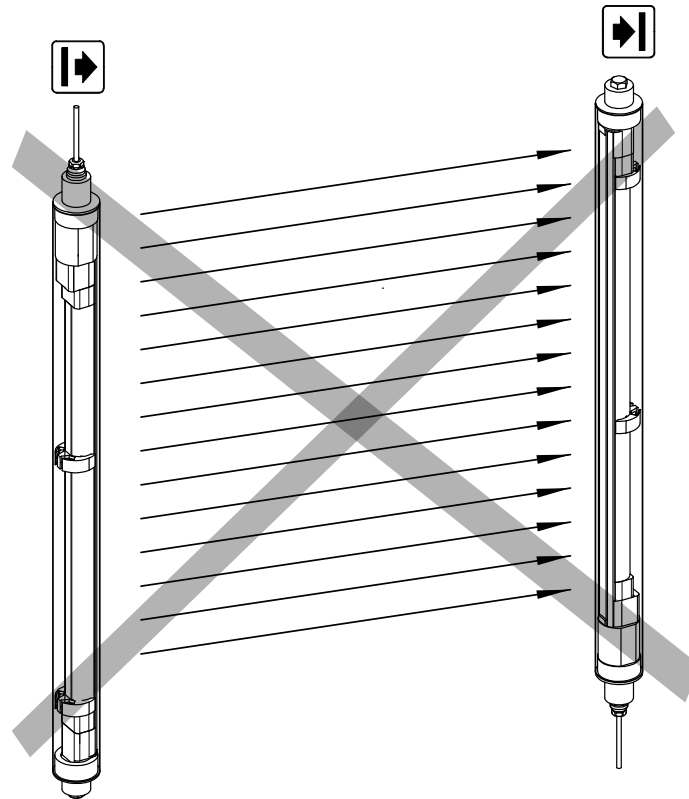

Figure 19: Sender and receiver must not be installed at 180° rotated relative to each other

- ▶ Mount the sender and receiver on a level surface.
- ▶ Mount the sender and receiver such that a right-angled protective field is established, i.e., when mounted vertically at the same height.
- ▶ If possible, select the mounting height of the top bracket such that the bracket rests as close to the 90° bend of the protective housing end cap as possible.
- ▶ In the event of vibratory/impact loads, mount additional stainless steel supporting brackets at regular intervals on the device.
- ▶ Tighten the screws used to mount the bracket to a torque of 5 Nm to 6 Nm. Tighten the screws used to secure the safety light curtain in the bracket to a torque of 4 Nm to 5 Nm. Higher torques can damage the bracket, while lower torques do not provide adequate fixation to prevent the safety light curtain from moving.
- ▶ When mounting, make sure that sender and receiver are aligned correctly. The optical lens systems of sender and receiver must be located opposite one another.
- ▶ If necessary, use a water level to check the components are parallel.

### 5.3.1 Mounting the reinforced stainless steel bracket

#### Overview

With the reinforced stainless steel bracket, the sender and receiver can be precisely aligned with the device axis even after mounting.

The sender and receiver are mounted with two reinforced stainless steel brackets each.

The reinforced stainless steel bracket consists of two parts, which are placed onto each other. The two parts are connected and the safety light curtain secured with two M5 screws.

An M8 screw with washer is used to mount the reinforced stainless steel bracket on a machine or profile frame.

**Important information****NOTE**

The following should be considered when mounting the reinforced stainless steel bracket:

- Select an appropriate screw length to prevent any risk of injury from an overrun
- Take the reinforced stainless steel bracket and the machine or profile frame into account when selecting the screw length, [see figure 27, page 61](#)

**Mounting the reinforced stainless steel bracket on a machine or profile frame**

Table 2: Mounting the reinforced stainless steel bracket on the side and back

Mounting method	Description
On the side	With the M8 screw through the reinforced stainless steel bracket to the machine or profile frame. A screw nut or threaded hole is required on the machine or profile frame.
	With the M8 screw through the machine or profile frame to the reinforced stainless steel bracket. A screw nut is required for each reinforced stainless steel bracket.
On the back	With the M8 screw through the reinforced stainless steel bracket to the machine or profile frame. A screw nut or threaded hole is required on the machine or profile frame.

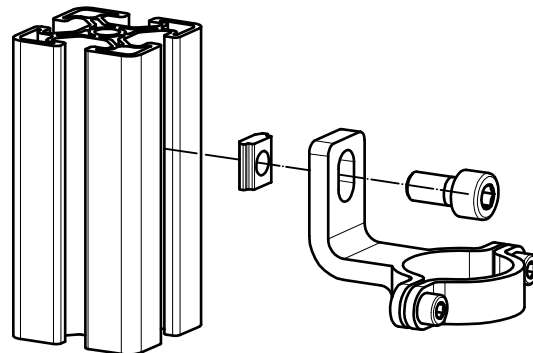

Figure 20: Mounting the reinforced stainless steel bracket on a profile frame

**Approach**

1. After mounting the reinforced stainless steel bracket, guide the sender/receiver into it.
2. Use the two M5 screws to fix the position of the sender/receiver in the reinforced stainless steel bracket.

**5.3.2 Mounting the stainless steel bracket****Overview**

With the stainless steel bracket, the sender and receiver can be rotated around their longitudinal axis.

The sender and receiver are mounted with two stainless steel brackets each.

The stainless steel bracket consists of two parts, which are pushed into each other. The two parts are connected and the safety light curtain secured with one M5 screw.

An M8 screw with washer is used to mount the stainless steel bracket on a machine or profile frame.

### Important information



#### NOTE

When mounting the stainless steel bracket, the M8 screw can present a risk of injury if it is too long. Select an appropriate screw length to prevent any risk of injury from an overrun.

### Mounting the stainless steel bracket on a machine or profile frame

Table 3: Mounting the stainless steel bracket on the side and back

Mounting method	Description
On the side	With the M8 screw through the stainless steel bracket to the machine or profile frame. A screw nut or threaded hole is required on the machine or profile frame.
On the back	With the M8 screw through the stainless steel bracket to the machine or profile frame. A screw nut or threaded hole is required on the machine or profile frame.

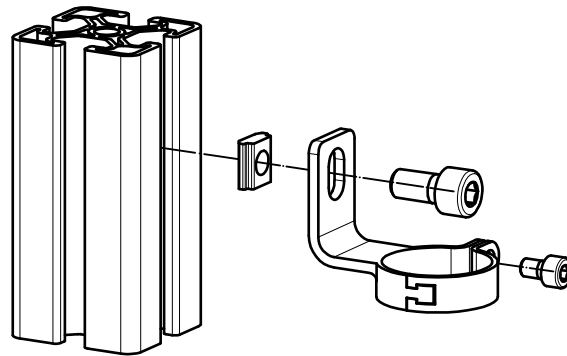

Figure 21: Mounting the stainless steel bracket on a profile frame

#### Approach

1. After mounting the stainless steel bracket, guide the sender/receiver into it.
2. Use the M5 screw to fix the position of the sender/receiver in the stainless steel bracket.

### 5.3.3 Mounting the stainless steel supporting bracket

#### Overview

In the event of vibratory/impact loads according to IEC 61496, devices must be fitted with additional stainless steel supporting brackets at a protective field height of 600 mm or above.

The stainless steel supporting bracket consists of two parts, which are placed onto each other. The two parts are connected and the device secured with one M5 screw.

#### Mounting instructions

The following should be considered when mounting the stainless steel supporting brackets:

- The stainless steel supporting brackets may only be used in conjunction with the reinforced stainless steel brackets
- They are mounted on the device at intervals of 300 mm to 350 mm at a protective field height of 600 mm or above

- The fixing hole for the stainless steel supporting bracket has a lateral deviation of 17.5 mm from the fixing hole for the reinforced stainless steel bracket
- The stainless steel supporting brackets and the reinforced stainless steel brackets are mounted on a machine or profile frame using M8 screws. Guide the device into the brackets and tighten the M5 screws for the reinforced stainless steel brackets first, followed by the M5 screws for the stainless steel supporting brackets. Finally, tighten the M8 screws.



### NOTE

To ensure the protective housing of the device does not become warped during mounting, only fully tighten the M8 screws right at the end of the mounting process.

---

## 6 Electrical installation

### 6.1 Safety

Information on the requirements that must be met for safe integration of the safety light curtain into the control and electronics of the machine: see ["Integrating into the electrical control"](#), page 23.

Mounting should be completed before electrical installation.



#### DANGER

Hazard due to electrical voltage

Hazard due to unexpected starting of the machine

- ▶ Make sure that the machine is (and remains) disconnected from the voltage supply during the electrical installation.
- ▶ Make sure that the dangerous state of the machine is (and remains) switched off during electrical installation.
- ▶ Make sure that the outputs of the safety light curtain have no effect on the machine during the electrical installation work.
- ▶ Use an appropriate voltage supply, see ["Technical data"](#), page 53.



#### DANGER

Hazard due to lack of effectiveness of the protective device

The dangerous state may not be stopped in the event of non-compliance.

- ▶ Always connect the two OSSDs separately. The two OSSDs must not be connected to each other.
- ▶ Connect the OSSDs such that the machine controller processes both signals separately.

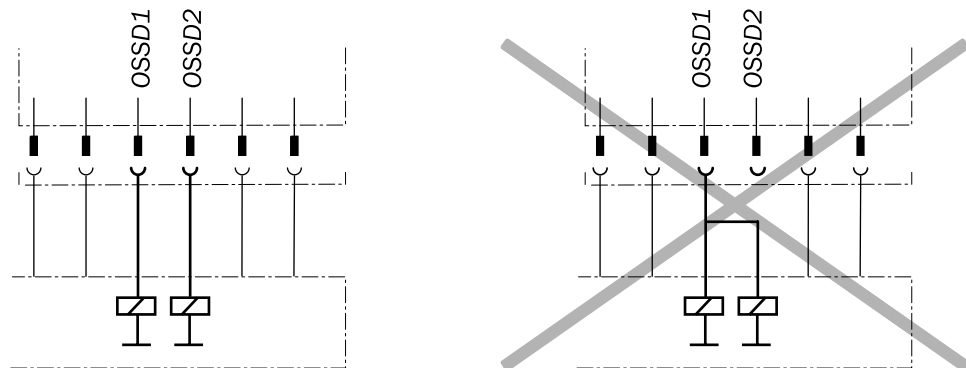

Figure 22: Dual-channel and isolated connection of OSSD1 and OSSD2



#### DANGER

Hazard due to lack of effectiveness of the protective device

The dangerous state may not be stopped in the event of non-compliance.

- ▶ Prevent the formation of a potential difference between the load and the protective device.

- If you connect loads to the OSSDs (safety outputs) that then also switch if controlled with negative voltage (e.g., electro-mechanical contactor without reverse polarity protection diode), you must connect the 0 V connections of these loads and those of the corresponding protective device individually and directly to the same 0 V terminal strip. In the event of a fault, this is the only way to ensure that there can be no potential difference between the 0 V connections of the loads and those of the corresponding protective device.

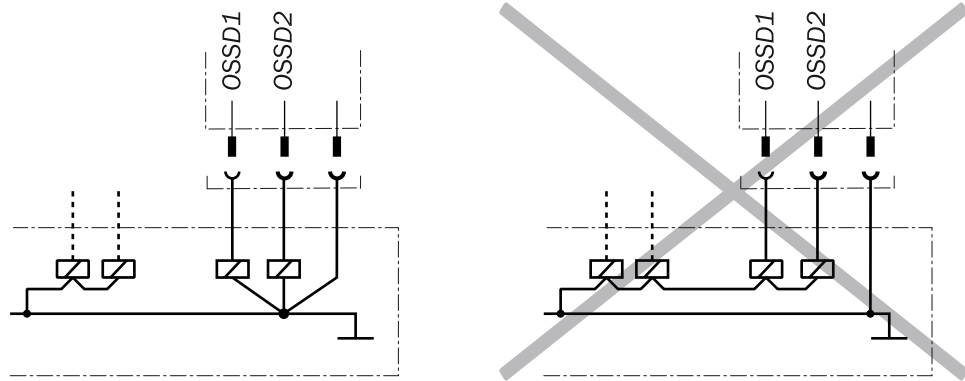

Figure 23: No potential difference between load and protective device

## 6.2 System connection (flying leads, 5-pin)

Table 4: System connection (flying leads, 5-pin)

Wire color	Sender	Receiver
Brown	+24 V DC (voltage supply input)	+24 V DC (voltage supply input)
White	Reserved	OSSD1 (output signal switching device 1)
Blue	0 V DC (voltage supply input)	0 V DC (voltage supply input)
Black	Reserved	OSSD2 (output signal switching device 2)
Gray	Not connected	Not connected

### Further topics

- ["Integrating into the electrical control", page 23](#)

## 7 Commissioning

### 7.1 Security



#### **DANGER**

Hazard due to lack of effectiveness of the protective device

When changes are made to the machine, the effectiveness of the protective device may be affected unintentionally.

- ▶ After every change to the machine and changes to the integration or operational and secondary conditions of the safety light curtain, check the protective device for effectiveness and recommission as specified in this chapter.



#### **DANGER**

Dangerous state of the machine

- ▶ Make sure that the dangerous state of the machine is (and remains) switched off during mounting, electrical installation, and commissioning.
- ▶ Make sure that the outputs of the safety light curtain do not affect the machine during mounting, electrical installation, and commissioning.



#### **DANGER**

Hazard due to lack of effectiveness of the protective device

- ▶ Before commissioning the machine, make sure that the machine is first checked and released by qualified safety personnel.
- ▶ Only operate the machine with a perfectly functioning protective device.



#### **DANGER**

Hazard due to lack of effectiveness of the protective device

Persons and parts of the body to be protected may not be recognized in case of non-observance.

1. Make sure that the optical properties of the protective housing of the sender and receiver are not changed during operation, e.g., by:
  - Beading water, mist, frost, or ice formation on the protective housing. Remove condensation of this kind or other types of contamination, then restart the receiver.
  - Scratches or damage to the protective housing. Replace the protective housing of the respective sender or receiver if its protective housing is scratched or damaged.
2. Make sure that all reflective surfaces and objects maintain a minimum distance from the protective field.
3. Make sure that no dispersive media (e.g., dust, fog, or smoke) are within the calculated minimum distance from the protective field.

#### **Further topics**

- ["Minimum distance to reflective surfaces", page 22](#)

### 7.2 Overview

The mounting and electrical installation work must be completed before commissioning as described in the following chapters:

- ["Design", page 18](#)
- ["Integrating into the electrical control", page 23](#)
- ["Mounting", page 31](#)
- ["Electrical installation", page 37](#)

### 7.3 Switching on

After switching on, the sender and receiver initialize. All light emitting diodes of the sender and receiver briefly light up. After initialization, the receiver displays the alignment quality using four blue light emitting diodes. Once the safety light beam curtain is aligned (OSSD LED: green), the alignment display switches off after a certain period of time, and only the PWR LED of the sender and the OSSD LED of the receiver continue to light up.

In the event of a fault, the red fault light emitting diode flashes on the respective device. The red fault light emitting diode in combination with the blue light emitting diodes show the cause of the fault on the side of the receiver, see ["Troubleshooting", page 49](#).

### 7.4 Sender and receiver alignment

#### Overview

After mounting and the electrical installation, the sender and receiver must be aligned with each other.



#### DANGER

Dangerous state of the machine

- ▶ Make sure that the dangerous state of the machine is (and remains) switched off during the alignment process.
  - ▶ Make sure that the outputs of the safety light curtain do not affect the machine during the alignment process.
- 

#### Further topics

- ["Mounting the reinforced stainless steel bracket", page 33](#)
- ["Mounting the stainless steel bracket", page 34](#)
- ["Indication of the alignment quality", page 43](#)

#### 7.4.1 Aligning the sender and receiver

##### Important information

---



#### DANGER

Dangerous state of the machine

- ▶ Make sure that the dangerous state of the machine is (and remains) switched off during the alignment process.
  - ▶ Make sure that the outputs of the safety light curtain do not affect the machine during the alignment process.
- 

#### Approach

1. Make sure that the sender and receiver are mounted correctly.
2. Switch on the voltage supply to the safety light curtain.
3. Roughly align the sender to the receiver by rotating the sender.
4. Rotate the receiver to align it to the sender so that as many blue alignment quality light emitting diodes as possible light up on the receiver.



5. If required, align the sender more precisely to the receiver so that as many alignment quality light emitting diodes as possible light up on the receiver.
6. If required, align the receiver more precisely to the sender so that as many alignment quality light emitting diodes as possible light up on the receiver.
7. When at least three (preferably four) alignment quality light emitting diodes light up on the receiver, fasten the components in the brackets. Torque: 4 Nm to 5 Nm.
8. Switch the voltage supply off and then on again.
9. Check the alignment quality light emitting diodes to make sure that the components are still correctly aligned with each other.

**NOTE**

Once three blue alignment quality light emitting diodes light up, alignment is good and availability is stable.

Please note that parts of the body or objects in the protective field (e.g., hand, tool) will impair the function of the alignment quality light emitting diodes. Remove all objects from the protective field to allow the alignment quality to be assessed.

**Further topics**

- ["Mounting", page 31](#)

## 7.4.2 Alignment with the reinforced stainless steel bracket

**Prerequisites**

- The sender and receiver have been mounted with a reinforced stainless steel bracket

**Alignment with the reinforced stainless steel bracket**

You can align the sender and receiver to each other as follows if the reinforced stainless steel bracket is used:

- Rotate

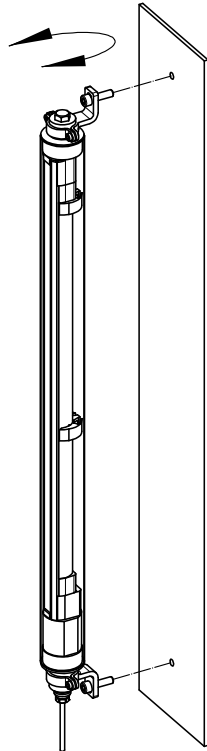

Figure 24: Rotating the sender or receiver in the reinforced stainless steel bracket

### 7.4.3 Alignment with the stainless steel bracket

#### Prerequisites

- The sender and receiver have been mounted with a stainless steel bracket

#### Alignment with the stainless steel bracket

You can align the sender and receiver to each other as follows if the stainless steel bracket is used:

- Rotate

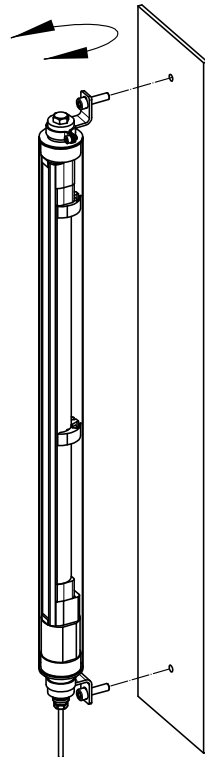

Figure 25: Rotating the sender or receiver in the stainless steel bracket

#### 7.4.4 Indication of the alignment quality

##### Important information



##### NOTE

Once three blue alignment quality light emitting diodes light up, alignment is good and availability is stable.

Please note that parts of the body or objects in the protective field (e.g., hand, tool) will impair the function of the alignment quality light emitting diodes. Remove all objects from the protective field to allow the alignment quality to be assessed.

##### Indication of the alignment quality

Table 5: Indication of the alignment quality

Indication		Meaning
Blue light emitting diodes	OSSD light emitting diode	
No light emitting diode lights up	● Red	Alignment is insufficient or the protective field is interrupted at least partially. The receiver cannot synchronize with the sender.
1 light emitting diode lights up	● Red	Alignment is insufficient or the protective field is interrupted at least partially.
2 light emitting diodes light up	● Red	Alignment is poor or the protective field is interrupted at least partially.
2 light emitting diodes light up	● Green	Alignment is not yet sufficient for stable availability.
3 light emitting diodes light up	● Green	Alignment is good, stable availability. <sup>1)</sup>

Indication		Meaning
Blue light emitting diodes	OSSD light emitting diode	
4 light emitting diodes light up	● Green	Alignment is very good.

<sup>1)</sup> If the protective fields are very wide, there is a possibility that all four alignment quality light emitting diodes will not light up even when alignment is excellent.

### 7.5 Check during commissioning and modifications

The check must detect if it is possible to enter the hazardous area without being detected.

- ▶ Carry out the checks according to the instructions from the manufacturer of the machine and from the operating entity.

## 8 Operation

### 8.1 Safety

**DANGER**

Hazard due to lack of effectiveness of the protective device

Persons and parts of the body to be protected may not be recognized in case of non-observance.

- ▶ Maintenance work, alignment work, fault diagnoses, and any changes to the integration of the protective device in the machine must only be carried out by qualified personnel.
- ▶ The effectiveness of the protective device must be checked following such work.

**DANGER**

Hazard due to lack of effectiveness of the protective device

Persons and parts of the body to be protected may not be recognized in case of non-observance.

1. Make sure that the optical properties of the protective housing of the sender and receiver are not changed during operation, e.g., by:
  - Beading water, mist, frost, or ice formation on the protective housing. Remove condensation of this kind or other types of contamination, then restart the receiver.
  - Scratches or damage to the protective housing. Replace the protective housing of the respective sender or receiver if its protective housing is scratched or damaged.
2. Make sure that all reflective surfaces and objects maintain a minimum distance from the protective field.
3. Make sure that no dispersive media (e.g., dust, fog, or smoke) are within the calculated minimum distance from the protective field.

**NOTE**

This document does not provide information on operating the machine in which the safety light curtain is integrated.

### 8.2 Regular thorough check

The check must detect if it is possible to enter the hazardous area without being detected. Such possibilities may exist due to modifications, manipulations or external influences.

- ▶ Carry out the checks according to the instructions from the manufacturer of the machine and from the operating entity.

### 9 Maintenance

The safety light curtain is maintenance-free. Depending on the ambient conditions, regular cleaning is required.

#### 9.1 Safety

---



##### **DANGER**

Hazard due to lack of effectiveness of the protective device

Persons and parts of the body to be protected may not be recognized in case of non-observance.

- ▶ Do not do repair work on device components.
  - ▶ Do not make changes to or manipulate device components.
  - ▶ Apart from the procedures described in this document, the device components must not be opened.
- 

#### 9.2 Regular cleaning

##### **Overview**

Depending on the ambient conditions of the safety light curtain, the protective housing must be cleaned regularly and in the event of contamination. Static charges can cause dust particles to be attracted to the protective housing. The deflector mirrors also must be cleaned regularly and in the event of contamination.

##### **Important information**

---



##### **DANGER**

Hazard due to lack of effectiveness of the protective device

Persons and parts of the body to be protected may not be recognized in case of non-observance.

- ▶ Regularly check the degree of contamination on all components based on the application conditions.
  - ▶ Observe the information concerning test rod testing.
- 



##### **DANGER**

Hazard due to lack of effectiveness of the protective device

Persons and parts of the body to be protected may not be recognized in case of non-observance.

1. Make sure that the optical properties of the protective housing of the sender and receiver are not changed during operation, e.g., by:
    - Beading water, mist, frost, or ice formation on the protective housing. Remove condensation of this kind or other types of contamination, then restart the receiver.
    - Scratches or damage to the protective housing. Replace the protective housing of the respective sender or receiver if its protective housing is scratched or damaged.
  2. Make sure that all reflective surfaces and objects maintain a minimum distance from the protective field.
  3. Make sure that no dispersive media (e.g., dust, fog, or smoke) are within the calculated minimum distance from the protective field.
-

**DANGER**

Hazard due to unexpected starting of the machine

- ▶ Make sure that the dangerous state of the machine is and remains switched off during the cleaning.
- ▶ Make sure that the outputs of the safety light curtain do not affect the machine during the cleaning process.

**NOTICE**

- ▶ Do not use any aggressive cleaning agents.
- ▶ Do not use any abrasive cleaning agents.
- ▶ We recommend anti-static cleaning agents.
- ▶ We recommend the use of anti-static plastic cleaner (SICK part number 5600006) and the SICK lens cloth (SICK part number 4003353).

**Approach**

1. Remove any contamination from the protective housing with plenty of water.
2. Wipe the protective housing with a clean, slightly damp cloth.
3. Then dry the protective housing with a clean cloth.
4. Check the position of the sender and receiver after cleaning.
5. Check the effectiveness of the protective device.

**Further topics**

- ["Operation", page 45](#)

## 9.3 Replacing the protective housing

**Overview**

If the protective housing is scratched or damaged, the protective housing must be replaced.

**Important information****NOTICE**

- ▶ The protective housing may only be replaced by qualified safety personnel.
- ▶ Replace the protective housing in an environment free of dust and dirt.
- ▶ Avoid soiling the inside of the protective housing.
- ▶ Do not use an additional sealant, such as silicone, for sealing the protective housing. Any vapors that are created may damage the optical components.
- ▶ Mount the protective housing according to the following instructions, to ensure IP 69K leak tightness of the housing.
- ▶ Only use a new protective housing as a replacement.

**NOTICE**

Enclosure rating IP 69K only applies if the protective housing and the cable gland are closed.

**Required tools**

- Screwdriver for the M5 and M8 mounting screws of the stainless steel brackets

### Approach

1. Make sure that the environment is clean and clear of fog, moisture, and dust.
2. Detach the bracket at the end furthest away from the cable.
3. Remove the defective protective housing and end cap at the end furthest away from the cable by rotating it gently.
4. Completely remove the protective film from the new protective housing.
5. Push the new protective housing on firmly as far as it will go.
6. Remount the device in the bracket.
7. Realign and check the device.

### Further topics

- ["Spare parts", page 60](#)
- ["Commissioning", page 39](#)

## 9.4 Regular thorough check

The check must detect if it is possible to enter the hazardous area without being detected. Such possibilities may exist due to modifications, manipulations or external influences.

- ▶ Carry out the checks according to the instructions from the manufacturer of the machine and from the operating entity.



## 10 Troubleshooting

This chapter describes how you identify and remedy faults that interrupt the function of the safety light curtain.

### 10.1 Safety



#### **DANGER**

Hazard due to lack of effectiveness of the protective device

Persons and parts of the body to be protected may not be recognized in case of non-observance.

- ▶ Immediately shut the machine down if the behavior of the machine cannot be clearly identified.
- ▶ Immediately put the machine out of operation if you cannot clearly identify or allocate the fault and if you cannot safely remedy the fault.
- ▶ Secure the machine so that it cannot switch on unintentionally.



#### **DANGER**

Hazard due to unexpected starting of the machine

- ▶ When any work is taking place, use the protective device to secure the machine or to ensure that the machine is not switched on unintentionally.



#### **DANGER**

Hazard due to lack of effectiveness of the protective device

Persons and parts of the body to be protected may not be recognized in case of non-observance.

- ▶ Do not do repair work on device components.
- ▶ Do not make changes to or manipulate device components.
- ▶ Apart from the procedures described in this document, the device components must not be opened.



#### **NOTE**

If you cannot remedy the fault with the help of the information provided in this chapter, please contact your respective SICK subsidiary.

### 10.2 Fault indicators

In the event of a fault, the type of fault is indicated by the LED display on the sender or receiver.

**Sender**

Table 6: Fault indicator on the sender

PWR LED (yellow)	ERR LED (red)	Possible cause	Rectification
○	○	No operating voltage or operating voltage is too low or internal fault	Check the voltage supply, see "Technical data", page 53. Switch off the power supply and on again. If the fault persists, replace the sender, see "Ordering information", page 59.
○	☀	The voltage was too high when operating the sender.	Check the voltage supply, see "Technical data", page 53. Replace the sender, see "Ordering information", page 59.
●	☀	Fault in the supply voltage	Check the voltage supply and power supply unit, see "Technical data", page 53. Switch off the power supply and on again. If the fault persists, replace the defective components, see "Ordering information", page 59.
☀	☀	The sender identified an internal fault.	Switch off the power supply and on again. If the fault persists, replace the sender, see "Ordering information", page 59.

**Receiver**

Table 7: Fault indicator on the receiver

OSSD LED (red)	ERR LED (red)	LED 1 2 3 4 (blue)	Possible cause	Rectification
●	☀	☀○○○	An internal fault has occurred.	Switch the voltage supply off and then on again. If the fault persists, replace the receiver, see "Ordering information", page 59.
●	☀	○☀○○	Fault in the supply voltage	Check the voltage supply and power supply unit, see "Technical data", page 53. Switch off the power supply and on again. If the fault persists, replace the defective components, see "Ordering information", page 59.

OSSD LED (red)	ERR LED (red)	LED 1 2 3 4 (blue)	Possible cause	Rectification
●	●	○○●○	The receiver has recognized beams from several senders.	Check the distance to senders of the same type. Make sure that light beams from another sender cannot hit the receiver, see <a href="#">"Protection against interference from systems in close proximity to each other"</a> , page 23. Switch the voltage supply off and on again.
●	●	○○○●	A fault or unexpected state was identified on the OSSDs of the system connection (e. g. over voltage, short-circuit to HIGH or short-circuit to LOW, cross-circuit, permissible load capacity exceeded)	Check the system wiring for a fault. Make sure that the OSSDs have been wired correctly, see <a href="#">"Integrating into the electrical control"</a> , page 23. Switch the voltage supply off and on again. If the fault persists, replace the defective components, see <a href="#">"Ordering information"</a> , page 59.

### 11 Decommissioning

#### 11.1 Protection of the environment

The safety light curtain has been designed to minimize its impact on the environment. It uses only minimum of power and natural resources.

- ▶ Always act in an environmentally responsible manner at work. Please note the following information regarding disposal.

#### 11.2 Disposal

Always dispose of serviceableness devices in compliance with local/national rules and regulations with respect to waste disposal.



#### NOTE

We will be glad to help you dispose of these devices on request.

---

## 12 Technical data

### 12.1 Data sheet

#### General system data

Table 8: General system data

	Minimum	Typical	Maximum
Protective field height, depending on type	300 mm ... 1,800 mm, 150-mm steps		
Resolution (detection capability), depending on the type	30 mm		
Protective field range <sup>1)</sup> Resolution 30 mm	0 m ... 10 m	0 m ... 12.5 m	
Protection class <sup>2)</sup>	III (IEC 61140)		
Enclosure rating	IP 65 (IEC 60529) IP 66 (IEC 60529) IP 67 (IEC 60529) IP 69K (ISO 20653)		
Supply voltage $V_s$ on the device <sup>3) 4)</sup>	19.2 V	24 V	28.8 V
Residual ripple <sup>5)</sup>			± 10%
Synchronization	Optical		
Type	Type 2 (IEC 614961)		
Category	Category 2 (ISO 13849-1)		
Test rate	31 s <sup>-1</sup>		
Performance level <sup>6)</sup>	PL c (ISO 13849-1)		
Safety Integrity Level <sup>6)</sup>	SIL1 (IEC 61508)		
SIL claim limit <sup>6)</sup>	SILCL1 (IEC 62061)		
PFHd (mean probability of a dangerous failure per hour)	3.1 × 10 <sup>-8</sup>		
T <sub>M</sub> (Mission Time)	20 years (ISO 13849-1)		
Safe state when a fault occurs	At least one OSSD is in the OFF state.		
Power-up delay of sender and receiver before ready			2 s

- 1) If the protective fields are very wide, there is a possibility that all four alignment quality LEDs will not light up even when alignment is good.
- 2) Safety extra-low voltage SELV/PELV
- 3) The external voltage supply must be capable of buffering brief power failures of 20 ms as specified in EN 60204-1. Suitable power supplies are available as accessories from SICK.
- 4) A fuse rated maximum 2 A shall be installed in the isolated 24 V DC power supply circuit to the device in order to limit the available current.
- 5) Within the limits of  $U_v$
- 6) For more detailed information on the exact configuration of your machine, please consult your respective SICK subsidiary.

**Type of material**

Table 9: Type of material

	Type of material
Protective housing	Acrylic glass (PMMA)
End caps	Stainless steel 1.4404
Cable gland	Stainless steel 1.4404 including silicone seal
Pressure equalizing element (aeration and ventilation membrane)	PA 6

**Sender**

Table 10: Technical specifications, sender

	Minimum	Typical	Maximum
Wavelength of sender		Near-infrared (NIR) - invisible	
Weight	Depending on the protective field height, see "Table of weights", page 57		

**Receiver**

Table 11: Technical specifications, receiver

	Minimum	Typical	Maximum
<b>Output signal switching devices (OSSDs)</b>	2 PNP semiconductors, short-circuit protected <sup>1)</sup> , cross-circuit monitored		
Response time	see "Response time", page 56		
Duration of OFF state	100 ms		
Switch-on delay		3 × response time	
ON state, switching voltage <sup>2)</sup> HIGH ( $U_{rms}$ )	$U_V - 2.25 V$	24 V	$U_V$
OFF state, switching voltage LOW <sup>2) 3)</sup>	0 V	0 V	2.0 V
Current-carrying capacity of the OSSDs			300 mA ea.
Leakage current of the OSSDs			2 mA at each
Load capacity			2.2 μF
Load inductance			2.2 h
<b>Test pulse data <sup>4)</sup></b>			
Test pulse range		150 μs	300 μs
Test pulse rate	3 s <sup>-1</sup>	5 s <sup>-1</sup>	10 s <sup>-1</sup>
<b>Permissible conductor resistance</b>			
between device and load <sup>5)</sup>			2.5 Ω

	Minimum	Typical	Maximum
Supply cable <sup>6)</sup>			1 Ω

- 1) Applies to the voltage range between -30 V and +30 V.
- 2) According to IEC 61131-2
- 3) The specified values are the switching voltage passed to the safety light curtain. If higher voltages are impressed from the outside, the maximum value of 2.0 V can be exceeded.
- 4) Applies to devices marked "(Rev. 1)" on the "Ident No." type label entry. For devices not marked "(Rev. 1)", the following applies: Load capacity (maximum) = 30 nF.
- 5) When active, the outputs are tested cyclically (brief LOW). When selecting the downstream controllers, make sure that the test signals do not result in deactivation when using the above parameters.
- 6) Applies to devices marked "(Rev. 1)" on the "Ident No." type label entry. For devices not marked "(Rev. 1)", the following applies: Test pulse width (typical) = 300 μs; test pulse width (maximum) = 350 μs.
- 7) Make sure to limit the individual conductor resistance to the downstream controller to this value to ensure that a cross-circuit between the outputs is reliably detected. (Also observe IEC 60204-1.)
- 8) The supply cable must not be used to connect other loads with the exception of the sender.

**Operating data**

Table 12: Operating data

	Minimum	Typical	Maximum
Connection	Flying leads, 5-pin, 15 m preassembled		
Ambient operating temperature <sup>2) 3)</sup>	-30 °C		+55 °C
Air humidity (non-condensing)	15 %		95 %
Storage temperature	-30 °C		+70 °C
Housing cross section	ø 50 mm		
Vibration resistance <sup>4)</sup>	5 g, 10 Hz ... 55 Hz (IEC 60068-2-6)		
Shock resistance <sup>5)</sup>	10 g, 16 ms (IEC 60068-2-27)		

- 1) Maximum permissible conductor resistances must be observed.
- 2) The temperature difference between sender and receiver must not exceed 25 K.
- 3) The cable belonging to the device incl. the associated connection plug must not be flexibly mounted under -25 °C.
- 4) Test conditions per axis: 1 octave/minute, amplitude: 0.35 mm, 20 sweeps
- 5) Test conditions per axis: 500 shocks

**12.2 Response time**

The response time depends on the resolution and protective field height of the system. The safety light curtain is available with the resolution of 30 mm.

Table 13: Response time dependent on the protective field height

Protective field height in mm	Response time in ms
300	10
450	10
600	10
750	11
900	11
1050	11
1200	12
1350	12
1500	13
1650	13
1800	13

**12.3 power consumption**

Table 14: Power consumption, sender and receiver

Protective field height in mm	Typical power consumption of sender in W	Typical power consumption of receiver in W <sup>1)</sup>
300	0.82	1.63
450	0.86	1.73
600	0.91	1.82
750	0.96	1.92
900	1.01	2.02
1050	1.06	2.11
1200	1.10	2.21



Protective field height in mm	Typical power consumption of sender in W	Typical power consumption of receiver in W <sup>1)</sup>
1350	1.15	2.30
1500	1.20	2.40
1650	1.25	2.50
1800	1.30	2.59

<sup>1)</sup> Power discharged again via the OSSDs depending on the connected OSSD load must be added to the table values.

## 12.4 Table of weights

Table 15: Weight of sender and receiver

Protective field height in mm	Weight with cable in g <sup>1)</sup>		Weight without cable in g <sup>1)</sup>	
	➔ Sender	➔ Receiver	➔ Sender	➔ Receiver
300	1480	1490	940	950
450	1640	1650	1100	1100
600	1810	1820	1270	1280
750	1970	1980	1430	1440
900	2130	2140	1590	1600
1050	2290	2300	1750	1760
1200	2450	2460	1910	1920
1350	2620	2630	2070	2080
1500	2770	2780	2230	2240
1650	2930	2940	2390	2400
1800	3090	3100	2550	2560

<sup>1)</sup> Tolerance: ± 50 g

12.5 Dimensional drawings

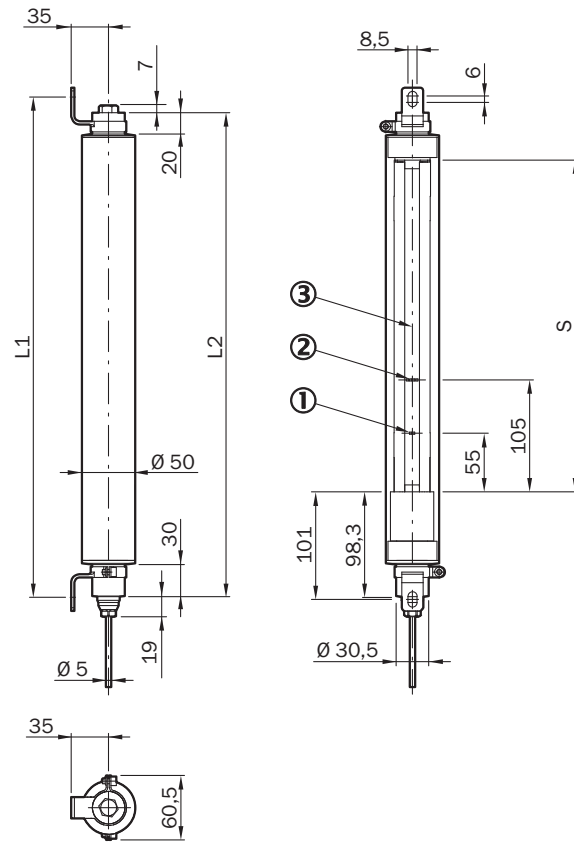

Figure 26: Dimensional drawing, sender and receiver

- 1 Status indicator
- 2 Alignment indicator
- 3 Optical axis

Table 16: Dimensions based on the protective field height, sender and receiver

Protective field height, nominal in mm	Protective field height, effective = dimension S in mm	L1 in mm	L2 in mm
300	311	470	455
450	461	620	605
600	611	771	756
750	761	921	906
900	911	1071	1056
1050	1061	1222	1207
1200	1211	1372	1357
1350	1360	1522	1507
1500	1510	1672	1657
1650	1660	1823	1808
1800	1810	1973	1958

## 13 Ordering information

### 13.1 Scope of delivery

#### Items supplied, sender

- Sender, mounted in protective housing, with 15 m connecting cable

#### Items supplied, receiver

- Receiver, mounted in protective housing, with 15 m connecting cable
- Test rod with diameter corresponding to the resolution of the safety light curtain
- Safety note
- Mounting Instructions
- Betriebsanleitung zum Download: [www.sick.com](http://www.sick.com)

### 13.2 Ordering information deTec2 Core IP69K

Table 17: Ordering information for deTec2 Core IP69K, resolution 30 mm

Protective field height in mm	☑ Sender		☑ Receiver	
	Part number	Type code	Part number	Type code
300	1219509	C2C-SB03030A10000	1219510	C2C-EB03030A10000
450	1219511	C2C-SB04530A10000	1219512	C2C-EB04530A10000
600	1219513	C2C-SB06030A10000	1219514	C2C-EB06030A10000
750	1219515	C2C-SB07530A10000	1219516	C2C-EB07530A10000
900	1219517	C2C-SB09030A10000	1219518	C2C-EB09030A10000
1050	1219519	C2C-SB10530A10000	1219520	C2C-EB10530A10000
1200	1219521	C2C-SB12030A10000	1219522	C2C-EB12030A10000
1350	1219523	C2C-SB13530A10000	1219524	C2C-EB13530A10000
1500	1219525	C2C-SB15030A10000	1219526	C2C-EB15030A10000
1650	1219527	C2C-SB16530A10000	1219528	C2C-EB16530A10000
1800	1219529	C2C-SB18030A10000	1219530	C2C-EB18030A10000

## 14 Spare parts

### 14.1 Protective housing

Table 18: Ordering information for protective housing

Designation	Protective field height in mm	Part number
Protective housing spare part, deTec IP69K	300	2096384
	450	2096385
	600	2096386
	750	2096387
	900	2096388
	1050	2096389
	1200	2096390
	1350	2096391
	1500	2096392
	1650	2096393
	1800	2096394

## 15 Accessories

### 15.1 Brackets

Part	Type code	Part number
Reinforced stainless steel bracket, rotatable	BEF-2SMMVAES4	2026850
Stainless steel bracket, rotatable	BEF-2SMMEAES4	2023708
Stainless steel supporting bracket	BEF-2AAAADES2	2026849

#### Reinforced stainless steel bracket, rotatable

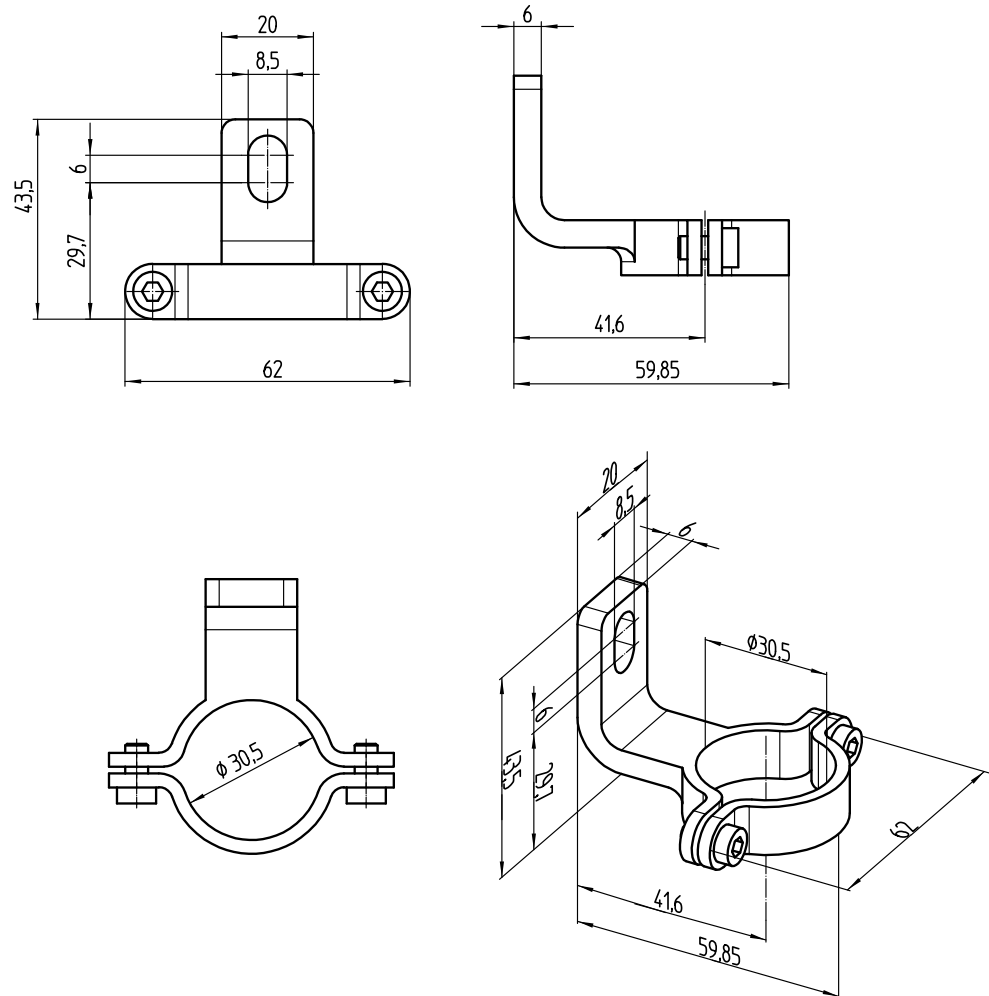

Figure 27: Dimensional drawing of the reinforced stainless steel bracket, rotatable (2026850)

Stainless steel bracket, rotatable

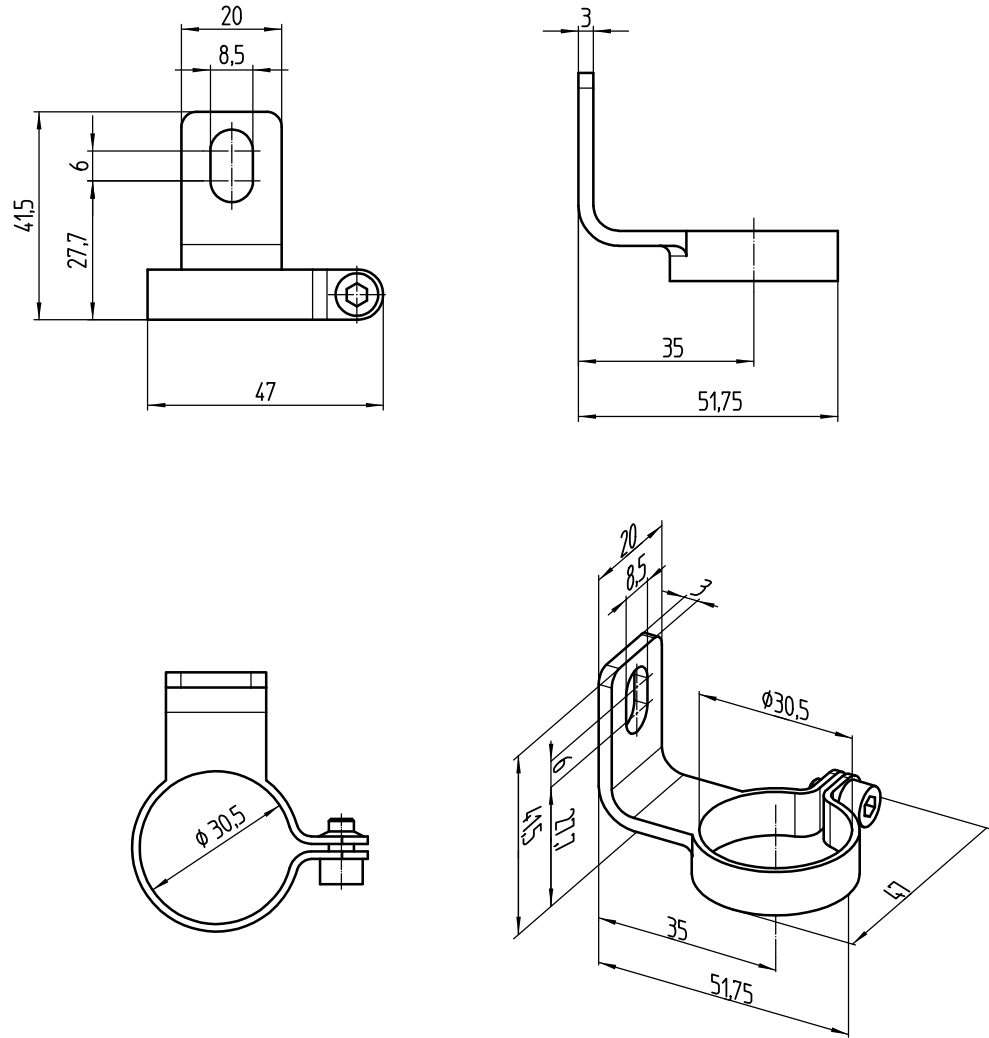

Figure 28: Dimensional drawing of the stainless steel bracket, rotatable (2023708)

## Stainless steel supporting bracket

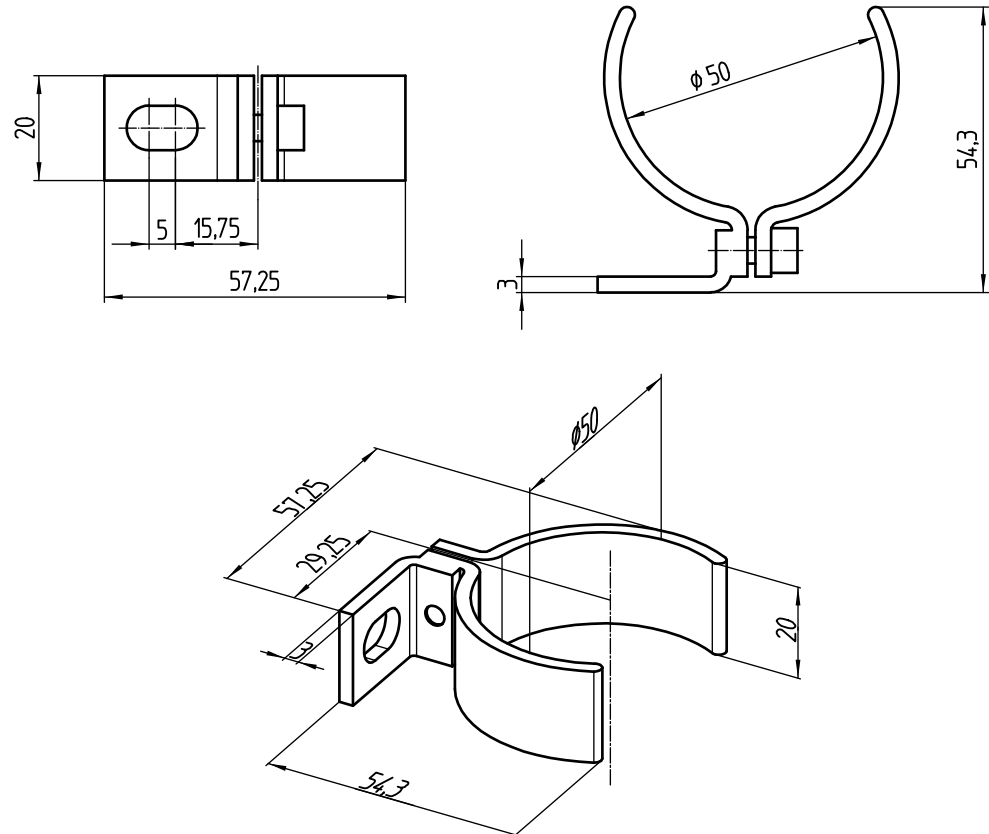

Figure 29: Dimensional drawing of the stainless steel supporting bracket (2026849)

## 15.2 Connectivity

### Power supply units

Table 19: Ordering information for power supply units

Part	Type code	Part number
Output 24 V DC, 50 W (2.1 A), voltage supply NEC Class 2, SELV, PELV, input 120 V AC ... 240 V AC	PS50WE24V	7028789
Output 24 V DC, 95 W (3.9 A), voltage supply NEC Class 2, SELV, PELV, input 100 V AC ... 120 V AC/220 V AC ... 240 V AC	PS95WE24V	7028790

## 15.3 Deflector mirrors

### Function and use

Deflector mirrors can be used to shape the protective field to secure hazardous points from multiple sides using a single safety light curtain.



**DANGER**

Hazard due to lack of effectiveness of the protective device

Persons and parts of the body to be protected may not be recognized in case of non-observance.

- ▶ Only mount deflector mirrors to solid walls or machine components. The position of the deflector mirrors must not change after alignment.
- ▶ Do not use deflector mirrors if contamination, beading water, condensation, or frost on the deflector mirrors is to be expected.
- ▶ Make sure that the deflector mirrors are intact and free of scratches, contamination, beading water, condensation, frost, etc. at all times.

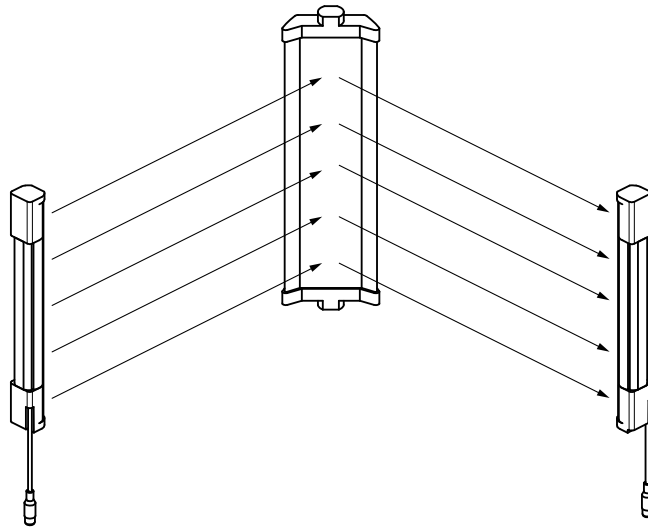

Figure 30: Example of use of deflector mirrors

Also pay attention to the mirror columns, see "Mirror columns", page 65.

**15.3.1 Mounting**

To mount the deflector mirrors, use the included swivel mount brackets.

**15.3.2 Change in scanning range using deflector mirrors**



**NOTE**

The use of deflector mirrors reduces the scanning range depending on the number of deflector mirrors in the protective field.

The information relates to 90° beam deflection per mirror and a protective field height of 900 mm.

Table 20: Scanning range with and without 1 or 2 deflector mirrors

Type	Resolution	Scanning range, typical <sup>1)</sup>	Scanning range with 1 deflector mirror, typical <sup>1)</sup>	Scanning range with 2 deflector mirrors, typical <sup>1)</sup>
PNS75, PNS125	30 mm	12.5 m	11.3 m	10.1 m

<sup>1)</sup> At a typical scanning range, there is a possibility that all four light emitting diodes to indicate alignment quality will not light up even when alignment is excellent.



### 15.3.3 Deflector mirror PNS75 - ordering information

Table 21: Ordering information, deflector mirror PNS75

Mirror length in mm	Max. protective field height in mm	Type code	Part number
340	300	PNS75-034	1019414
490	450	PNS75-049	1019415
640	600	PNS75-064	1019416
790	750	PNS75-079	1019417
940	900	PNS75-094	1019418
1090	1050	PNS75-109	1019419
1240	1200	PNS75-124	1019420
1390	1350	PNS75-139	1019421
1540	1500	PNS75-154	1019422
1690	1650	PNS75-169	1019423
1840	1800	PNS75-184	1019424

### 15.3.4 Deflector mirror PSN125 - ordering information

Table 22: Ordering information, deflector mirror PSN125

Mirror length in mm	Max. protective field height in mm	Type code	Part number
340	300	PNS125-034	1019425
490	450	PNS125-049	1019426
640	600	PNS125-064	1019427
790	750	PNS125-079	1019428
940	900	PNS125-094	1019429
1090	1050	PNS125-109	1019430
1240	1200	PNS125-124	1019431
1390	1350	PNS125-139	1019432
1540	1500	PNS125-154	1019433
1690	1650	PNS125-169	1019434
1840	1800	PNS125-184	1019435

## 15.4 Mirror columns and device columns

### 15.4.1 Mirror columns

Observe the information on deflector mirrors, particularly on changing the scanning range, see ["Deflector mirrors"](#), page 63.

Table 23: Ordering information for mirror columns

Column height	Mirror length	Type code	Part number
1281.5 mm	1082 mm	PM3C13-00030000	1043453
1569 mm	1382 mm	PM3C15-00030000	1077525
1716.5 mm	1532 mm	PM3C17-00030000	1043454
2016.5 mm	1682 mm	PM3C19-00030000	1043455
2216.5 mm	1832 mm	PM3C20-00030000	1043456

15.4.2 Device columns

Table 24: Ordering information for device columns

Column height	Max. installation length	Type code	Part number
985 mm	965 mm	PU3H96-00000000	2045490
1185 mm	1165 mm	PU3H11-00000000	2045641
1285 mm	1265 mm	PU3H13-00000000	2045642
1570 mm	1550 mm	PU3H15-00000000	2068813
1740 mm	1720 mm	PU3H17-00000000	2045643
2040 mm	2020 mm	PU3H21-00000000	2045644
2270 mm	2250 mm	PU3H22-00000000	2045645
2420 mm	2400 mm	PU3H24-00000000	2045646

15.5 Cleaning agent

Table 25: Cleaning agent ordering information

Part	Part number
Anti-static plastic cleaner	5600006
Lens cloth	4003353

15.6 Test rods

Table 26: Ordering information, test rods

Part	Part number
Test rod 30 mm	2022602
Test rod holder	2052249

## 16 Annex

### 16.1 Compliance with EU directives

#### EU declaration of conformity (excerpt)

The undersigned, who represents the manufacturer below, hereby declares that the product complies with the regulations of the EU directive(s) below (including all relevant changes), and that it is based on the relevant standards and/or technical specifications.

#### Complete EU declaration of conformity for download

You can call up the EU declaration of conformity and the current operating instructions for the protective device by entering the part number in the search field at [www.sick.com](http://www.sick.com) (part number: see the type label entry in the "Ident. no." field).

## 16.2 Checklist for initial commissioning and commissioning

### Checklist for manufacturers or installers for installing electro-sensitive protective device (ESPE)

The details relating to the items listed below must be available no later than when the system is commissioned for the first time. However, these depend on the specific application (the requirements of which must be reviewed by the manufacturer or installer).

This checklist should be retained and kept with the machine documentation to serve as reference during recurring tests.

This checklist does not replace the initial commissioning, nor the regular inspection by qualified safety personnel.

Have the safety rules and regulations been observed in compliance with the directives and standards applicable to the machine?	Yes <input type="checkbox"/> No <input type="checkbox"/>
Are the applied directives and standards listed in the declaration of conformity?	Yes <input type="checkbox"/> No <input type="checkbox"/>
Does the protective device comply with the required PL/SIL claim limit and PFHd in accordance with EN ISO 13849-1/EN 62061 and the required type in accordance with EN 61496-1?	Yes <input type="checkbox"/> No <input type="checkbox"/>
Is access to the hazardous area or hazardous point only possible through the protective field of the ESPE?	Yes <input type="checkbox"/> No <input type="checkbox"/>
Have appropriate measures been taken to protect (mechanical protection) or monitor (protective devices) any persons or objects in the hazardous area when protecting a hazardous area or hazardous point, and have these devices been secured or locked to prevent their removal?	Yes <input type="checkbox"/> No <input type="checkbox"/>
Are additional mechanical protective measures fitted and secured against manipulation which prevent reaching below, above or around the ESPE?	Yes <input type="checkbox"/> No <input type="checkbox"/>
Has the maximum shutdown and/or stopping time of the machine been measured, specified and documented (at the machine and/or in the machine documentation)?	Yes <input type="checkbox"/> No <input type="checkbox"/>
Has the ESPE been mounted such that the required minimum distance from the nearest hazardous point has been achieved?	Yes <input type="checkbox"/> No <input type="checkbox"/>
Are the ESPE devices properly mounted and secured against manipulation after adjustment?	Yes <input type="checkbox"/> No <input type="checkbox"/>
Are the required protective measures against electric shock in effect (protection class)?	Yes <input type="checkbox"/> No <input type="checkbox"/>
Is the control switch for resetting the protective devices (ESPE) or restarting the machine present and correctly installed?	Yes <input type="checkbox"/> No <input type="checkbox"/>
Are the outputs of the ESPE (OSSDs or safety outputs via the network) integrated according to the required PL/SILCL in accordance with EN ISO 13849-1/EN 62061 and does the integration correspond to the circuit diagrams?	Yes <input type="checkbox"/> No <input type="checkbox"/>
Has the protective function been checked in compliance with the test notes of this documentation?	Yes <input type="checkbox"/> No <input type="checkbox"/>
Are the specified protective functions effective at every operating mode that can be set?	Yes <input type="checkbox"/> No <input type="checkbox"/>
Are the switching elements activated by the ESPE, e.g. contactors, valves, monitored?	Yes <input type="checkbox"/> No <input type="checkbox"/>
Is the ESPE effective over the entire period of the dangerous state?	Yes <input type="checkbox"/> No <input type="checkbox"/>
Once initiated, will a dangerous state be stopped when switching the ESPE on or off and when changing the operating mode, or when switching to another protective device?	Yes <input type="checkbox"/> No <input type="checkbox"/>

### 16.3 Note on specified standards

Standards are specified in this document. The table shows regional standards with similar or identical contents.

Table 27: Note on specified standards

Standard	Standard (regional)
	China
IEC 60068-2-6	GB/T 2423.10
IEC 60068-2-27	GB/T 2423.5
IEC 60204-1	GB 5226.1
IEC 60529	GB 4208
IEC 60825	GB 7247.1
IEC 61131-2	GB/T 15969.1
IEC 61140	GB/T 17045
IEC 61496-1	GB/T 19436.1
IEC 61496-3	GB/T 19436.3
IEC 61508	GB/T 20438
IEC 62061	GB 28526
ISO 13849-1	GB/T 16855.1
ISO 13855	GB/T 19876

17 List of figures

1. Sender and receiver..... 11

2. Sender indicators..... 14

3. Receiver indicators..... 15

4. Hazardous point protection..... 16

5. Access protection..... 16

6. Hazardous area protection..... 17

7. Minimum distance to hazardous point for orthogonal (right-angled) approach to protective field..... 20

8. Representation of the accessibility of electro-sensitive protective device by reaching over. Left: Protective field that cannot be reached over. Right: Protective field that can be reached over..... 21

9. Minimum distance to reflective surfaces..... 22

10. Graph, minimum distance from reflective surfaces..... 22

11. Preventing mutual interference from system ① and system ②..... 23

12. Trouble-free operation due to reversed direction of transmission of system ① and system ②..... 23

13. Dual-channel and isolated connection of OSSD1 and OSSD2..... 24

14. No potential difference between load and protective device..... 25

15. Schematic representation of operation with restart interlock..... 26

16. Connection diagram for UE48-20S with restart interlock and external device monitoring..... 27

17. Test rod check: Step 1..... 29

18. Test rod check: Step 2..... 30

19. Sender and receiver must not be installed at 180° rotated relative to each other ..... 33

20. Mounting the reinforced stainless steel bracket on a profile frame..... 34

21. Mounting the stainless steel bracket on a profile frame..... 35

22. Dual-channel and isolated connection of OSSD1 and OSSD2..... 37

23. No potential difference between load and protective device..... 38

24. Rotating the sender or receiver in the reinforced stainless steel bracket..... 42

25. Rotating the sender or receiver in the stainless steel bracket..... 43

26. Dimensional drawing, sender and receiver..... 58

27. Dimensional drawing of the reinforced stainless steel bracket, rotatable (2026850)..... 61

28. Dimensional drawing of the stainless steel bracket, rotatable (2023708)..... 62

29. Dimensional drawing of the stainless steel supporting bracket (2026849)..... 63

30. Example of use of deflector mirrors..... 64

## 18 List of tables

1.	Formula for calculating the minimum distance for reflective surfaces.....	23
2.	Mounting the reinforced stainless steel bracket on the side and back.....	34
3.	Mounting the stainless steel bracket on the side and back.....	35
4.	System connection (flying leads, 5-pin).....	38
5.	Indication of the alignment quality.....	43
6.	Fault indicator on the sender.....	50
7.	Fault indicator on the receiver.....	50
8.	General system data.....	53
9.	Type of material.....	54
10.	Technical specifications, sender.....	54
11.	Technical specifications, receiver.....	54
12.	Operating data.....	56
13.	Response time dependent on the protective field height.....	56
14.	Power consumption, sender and receiver.....	56
15.	Weight of sender and receiver.....	57
16.	Dimensions based on the protective field height, sender and receiver.....	58
17.	Ordering information for deTec2 Core IP69K, resolution 30 mm.....	59
18.	Ordering information for protective housing.....	60
19.	Ordering information for power supply units.....	63
20.	Scanning range with and without 1 or 2 deflector mirrors.....	64
21.	Ordering information, deflector mirror PNS75.....	65
22.	Ordering information, deflector mirror PSN125.....	65
23.	Ordering information for mirror columns.....	65
24.	Ordering information for device columns.....	66
25.	Cleaning agent ordering information.....	66
26.	Ordering information, test rods.....	66
27.	Note on specified standards.....	69

**Australia**

Phone +61 3 9457 0600  
1800 334 802 - tollfree  
E-Mail sales@sick.com.au

**Austria**

Phone +43 22 36 62 28 8-0  
E-Mail office@sick.at

**Belgium/Luxembourg**

Phone +32 2 466 55 66  
E-Mail info@sick.be

**Brazil**

Phone +55 11 3215-4900  
E-Mail marketing@sick.com.br

**Canada**

Phone +1 905 771 14 44  
E-Mail information@sick.com

**Czech Republic**

Phone +420 2 57 91 18 50  
E-Mail sick@sick.cz

**Chile**

Phone +56 2 2274 7430  
E-Mail info@schadler.com

**China**

Phone +86 20 2882 3600  
E-Mail info.china@sick.net.cn

**Denmark**

Phone +45 45 82 64 00  
E-Mail sick@sick.dk

**Finland**

Phone +358-9-2515 800  
E-Mail sick@sick.fi

**France**

Phone +33 1 64 62 35 00  
E-Mail info@sick.fr

**Germany**

Phone +49 211 5301-301  
E-Mail info@sick.de

**Hong Kong**

Phone +852 2153 6300  
E-Mail ghk@sick.com.hk

**Hungary**

Phone +36 1 371 2680  
E-Mail office@sick.hu

**India**

Phone +91 22 6119 8900  
E-Mail info@sick-india.com

**Israel**

Phone +972 4 6881000  
E-Mail info@sick-sensors.com

**Italy**

Phone +39 02 274341  
E-Mail info@sick.it

**Japan**

Phone +81 3 5309 2112  
E-Mail support@sick.jp

**Malaysia**

Phone +6 03 8080 7425  
E-Mail enquiry.my@sick.com

**Mexico**

Phone +52 (472) 748 9451  
E-Mail mario.garcia@sick.com

**Netherlands**

Phone +31 30 2044 000  
E-Mail info@sick.nl

**New Zealand**

Phone +64 9 415 0459  
0800 222 278 - tollfree  
E-Mail sales@sick.co.nz

**Norway**

Phone +47 67 81 50 00  
E-Mail sick@sick.no

**Poland**

Phone +48 22 539 41 00  
E-Mail info@sick.pl

**Romania**

Phone +40 356 171 120  
E-Mail office@sick.ro

**Russia**

Phone +7 495 775 05 30  
E-Mail info@sick.ru

**Singapore**

Phone +65 6744 3732  
E-Mail sales.gsg@sick.com

**Slovakia**

Phone +421 482 901201  
E-Mail mail@sick-sk.sk

**Slovenia**

Phone +386 591 788 49  
E-Mail office@sick.si

**South Africa**

Phone +27 11 472 3733  
E-Mail info@sickautomation.co.za

**South Korea**

Phone +82 2 786 6321  
E-Mail info@sickkorea.net

**Spain**

Phone +34 93 480 31 00  
E-Mail info@sick.es

**Sweden**

Phone +46 10 110 10 00  
E-Mail info@sick.se

**Switzerland**

Phone +41 41 619 29 39  
E-Mail contact@sick.ch

**Taiwan**

Phone +886 2 2375-6288  
E-Mail sales@sick.com.tw

**Thailand**

Phone +66 2645 0009  
E-Mail Ronnie.Lim@sick.com

**Turkey**

Phone +90 216 528 50 00  
E-Mail info@sick.com.tr

**United Arab Emirates**

Phone +971 4 88 65 878  
E-Mail info@sick.ae

**United Kingdom**

Phone +44 1727 831121  
E-Mail info@sick.co.uk

**USA**

Phone +1 800 325 7425  
E-Mail info@sick.com

**Vietnam**

Phone +84 945452999  
E-Mail Ngo.Duy.Linh@sick.com

Further locations at [www.sick.com](http://www.sick.com)

