

# GRTB18(S)V

Cylindrical photoelectric sensors

en, de, fr, pt, it, es, zh, ja, ru

**SICK**  
Sensor Intelligence.



# GRTB18(S)V

Cylindrical photoelectric sensors

**SICK**  
Sensor Intelligence.



de  
en  
es  
fr  
it  
ja  
pt  
ru  
zh

---

**Described product**

GR18 Inox  
GRTB18(S)V

**Manufacturer**

SICK AG  
Erwin-Sick-Str. 1  
79183 Waldkirch  
Germany

**Production location**

SICK, Malaysia

**Legal information**

This work is protected by copyright. Any rights derived from the copyright shall be reserved for SICK AG. Reproduction of this document or parts of this document is only permissible within the limits of the legal determination of Copyright Law. Any modification, abridgment or translation of this document is prohibited without the express written permission of SICK AG.

The trademarks stated in this document are the property of their respective owner.

© SICK AG. All rights reserved.

**Original document**

This document is an original document of SICK AG.



## Contents

<b>1</b>	<b>Safety notes.....</b>	<b>5</b>
<b>2</b>	<b>Intended use.....</b>	<b>5</b>
<b>3</b>	<b>Operating and status indicators.....</b>	<b>5</b>
<b>4</b>	<b>Mounting.....</b>	<b>6</b>
<b>5</b>	<b>Electrical installation.....</b>	<b>7</b>
<b>6</b>	<b>Commissioning.....</b>	<b>8</b>
<b>7</b>	<b>Troubleshooting.....</b>	<b>10</b>
	7.1 Troubleshooting table.....	10
<b>8</b>	<b>Disassembly and disposal.....</b>	<b>11</b>
<b>9</b>	<b>Maintenance.....</b>	<b>11</b>
<b>10</b>	<b>Technical specifications.....</b>	<b>12</b>

## 1 Safety notes

- Read the operating instructions before commissioning.
-  Connection, mounting, and setting may only be performed by skilled person.
- Not a safety component in accordance with the EU Machinery Directive.
- Power supply: Class 2  
Enclosure type 1
- When commissioning, protect the device from moisture and contamination.
- These operating instructions contain information required during the life cycle of the sensor.

## 2 Intended use

The GRTB18(S)V is an opto-electronic photoelectric proximity sensor (referred to as “sensor” in the following) for the optical, non-contact detection of objects, animals, and persons. If the product is used for any other purpose or modified in any way, any warranty claim against SICK AG shall become void.

## 3 Operating and status indicators

Photoelectric proximity sensor with background suppression.

Table 1: Dimensional drawings

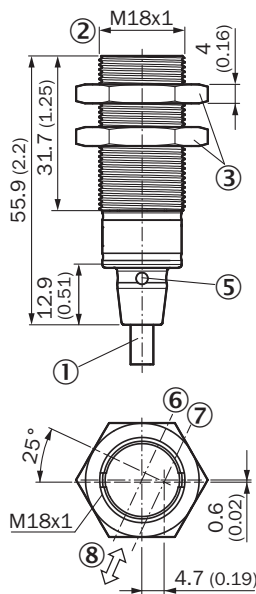

Figure 1: Short variant, connecting cable

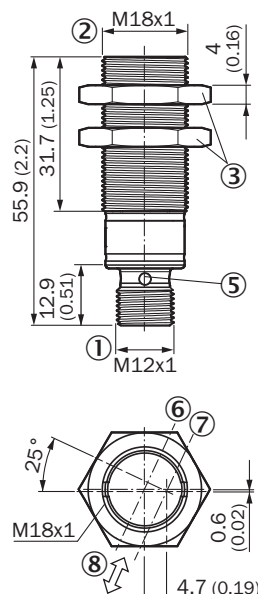

Figure 2: Short variant, M12 male connector

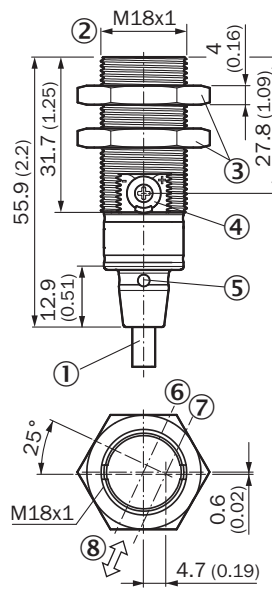

Figure 3: Short variant, potentiometer, connecting cable

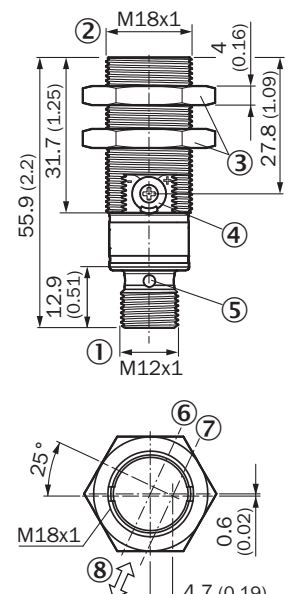

Figure 4: Short variant, potentiometer, M12 male connector

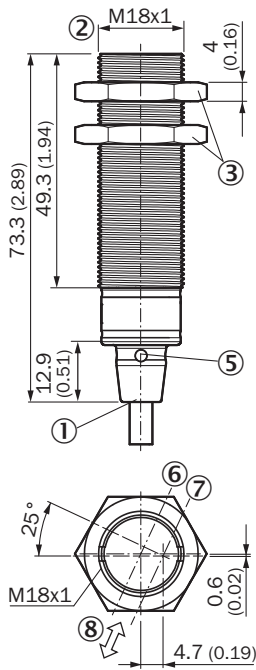

Figure 5: Long variant, connecting cable

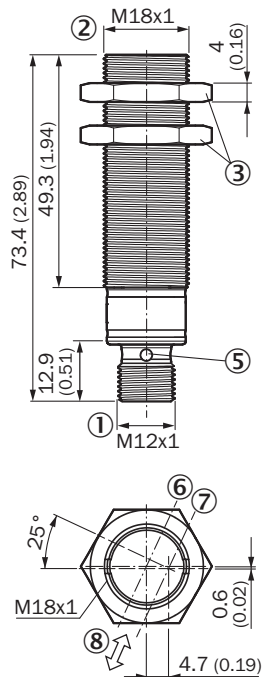

Figure 6: Long variant, M12 male connector

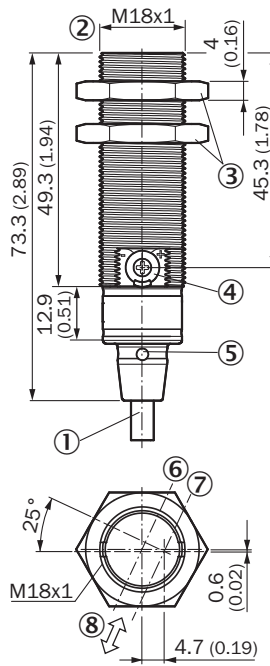

Figure 7: Long variant, potentiometer, connecting cable

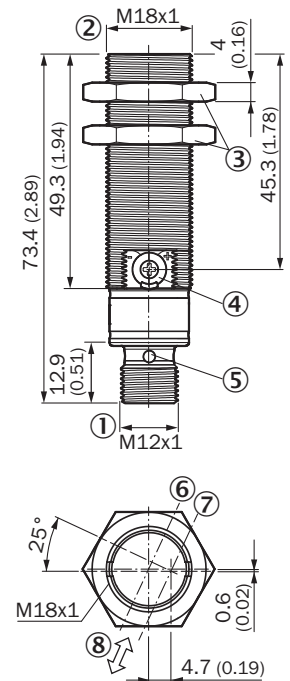

Figure 8: Long variant, potentiometer, M12 male connector

- ① Connection
- ② Mounting bracket M18 x 1
- ③ Fastening nuts (2 x); WS24, stainless steel
- ④ Potentiometer, 270°
- ⑤ LED indicator (4 x)
- ⑥ Optical axis, receiver
- ⑦ Optical axis, sender
- ⑧ Standard direction

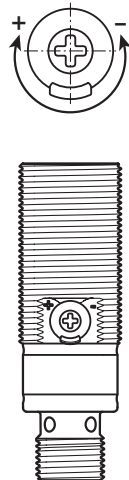
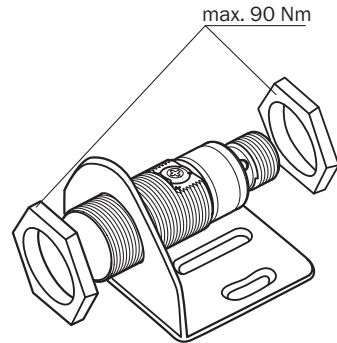

Figure 9: Operating element: Sensing range

## 4 Mounting

Mount the sensor using a suitable mounting bracket (see the SICK range of accessories).



Note the sensor's maximum permissible tightening torque of 90 Nm.

Note the preferred direction of the object relative to the sensor, cf. [table 1](#).

## 5 Electrical installation

The sensors must be connected in a voltage-free state ( $U_V = 0\text{ V}$ ). The following information must be observed, depending on the connection type:

- Male connector connection: pin assignment
- Cable: wire color

Only apply voltage/switch on the voltage supply ( $U_V > 0\text{ V}$ ) once all electrical connections have been established. The green LED indicator lights up on the sensor.

Explanations of the connection diagram (Tables 2 and 3):

$Q / \bar{Q}$  = switching outputs

n. c. = not connected

**DC: 10... 30 V DC, see „Technical specifications“, page 12**

Table 2: DC

GRTB18(S)V	x11xxx	x13xxx	x24xxx	x23xxx
1	+ (L+)	+ (L+)	+ (L+)	+ (L+)
2	$\bar{Q}$	n. c.	$\bar{Q}$	n. c.
3	- (M)	- (M)	- (M)	- (M)
4	Q	Q	Q	Q
	<p>1 = brn 2 = wht 3 = blu 4 = blk 0.14 mm<sup>2</sup> AWG26</p>	<p>1 = brn - 3 = blu 4 = blk 0.14 mm<sup>2</sup> AWG26</p>		

Table 3: DC

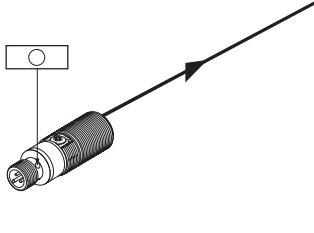
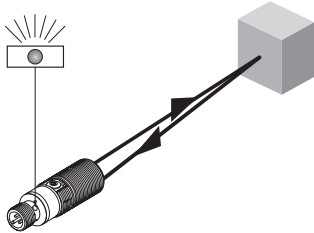
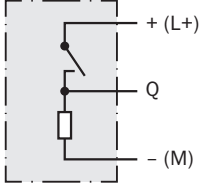
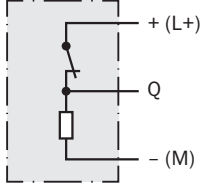
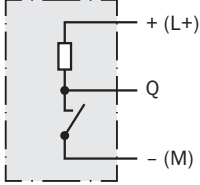
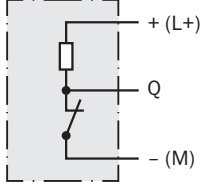
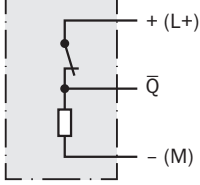
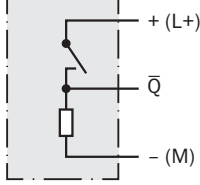
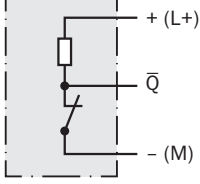
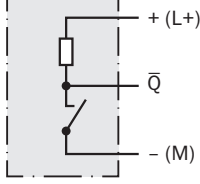
		
PNP: Q ( $\leq 100$ mA)		
NPN: Q ( $\leq 100$ mA)		
PNP: $\bar{Q}$ ( $\leq 100$ mA)		
NPN: $\bar{Q}$ ( $\leq 100$ mA)		

## 6 Commissioning

### 1 Alignment

Align the sensor with the object. Select the position so that the red emitted light beam hits the center of the object. You must ensure that the optical opening (front screen) of the sensor is completely clear [see figure].

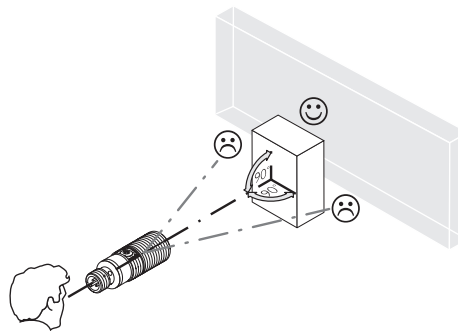

Figure: Alignment

### 2 Sensing range



Check the application conditions: Adjust the sensing range and distance to the object or background and the remission capability of the object according to the corresponding diagram [see figure 10] (x = sensing range, y = monitored area between the set sensing range and background suppression as a % of the sensing range (object remission/background remission)). Remission: 6% = black ①, 18% = gray ②, 90% = white ③ (referring to standard white as per DIN 5033). We recommend making the adjustments using an object with a low remission.

The minimum distance (= y) for background suppression can be determined from diagram [see figure 10 ①] as follows:

Example: x = 150 mm, y = 20 => 20% of 150 mm = 30 mm. That is, the background is suppressed at a distance of > 180 mm from the sensor.

Minimum distance between set sensing range and background (white, 90%) in % of sensing range

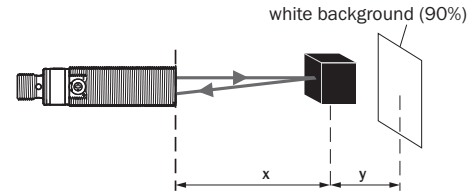
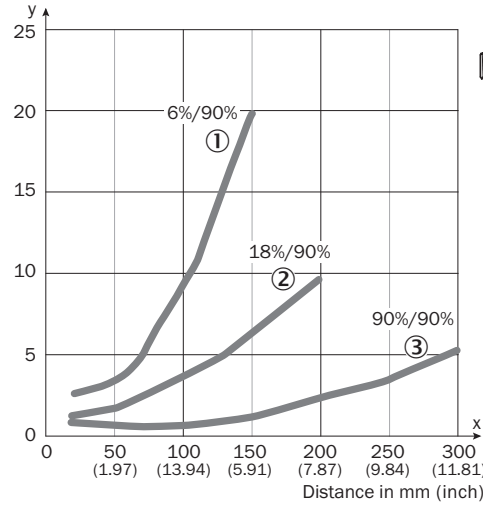

Example:  
Sensing range on black, 6%  
x = 100 mm, y = (10% of 100 mm) = 10 mm

- ① Sensing range on black, 6 % remission
- ② Sensing range on gray, 18 % remission
- ③ Sensing range on white, 90 % remission

Figure 10: Sensing range of up to 300 mm

Use figure 11 and Table 3 to check the function. If the switching output fails to behave in accordance with Table 3, check the application conditions. See section Fault diagnosis.

### 3 Sensing range setting

Sensor which it is not possible to set: The sensor is adjusted and ready for operation. The sensing range is adjusted with the potentiometer (type: 270°). Clockwise rotation: sensing range increased; counterclockwise rotation: sensing range reduced. We recommend placing the object within the sensing range, e.g. see table 4. Once the sensing range has been adjusted, the object is removed from the path of the beam, which causes the background to be suppressed and the switching output to change [see table 3].

Table 4: Sensing range setting

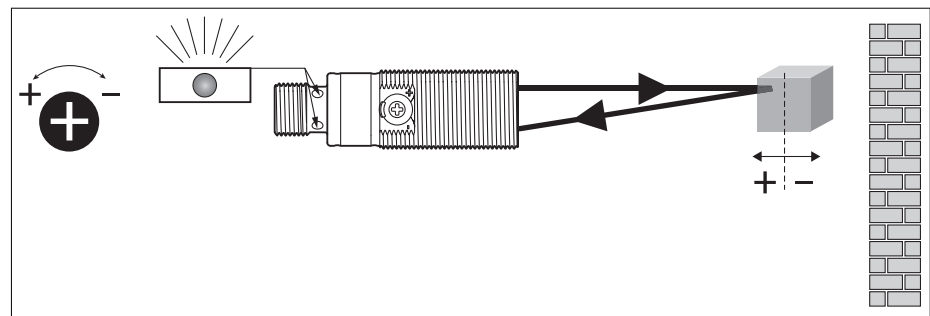

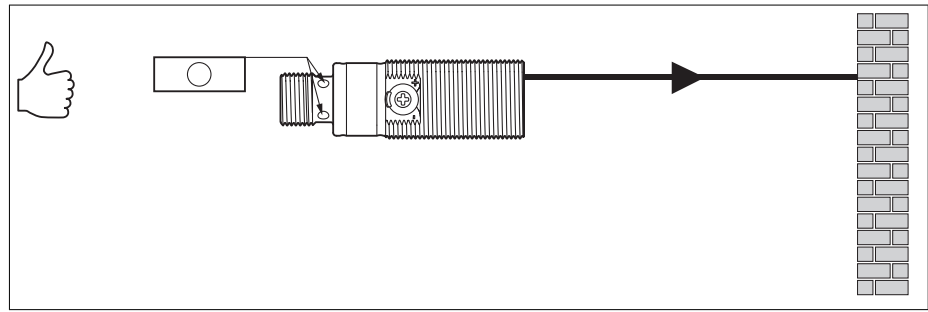

The sensor is adjusted and ready for operation.

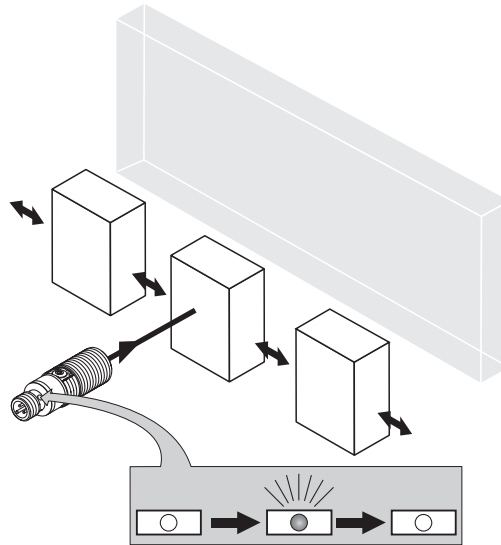

Figure 11: Detection

## 7 Troubleshooting

The Troubleshooting table indicates which measures are to be taken if the sensor stops working.

### 7.1 Troubleshooting table

Table 5: Troubleshooting

LED indicator/fault pattern	Cause	Measures
Green LED does not light up	No voltage or voltage below the limit values	Check the power supply, check all electrical connections (cables and plug connections)
Green LED does not light up	Voltage interruptions	Ensure there is a stable power supply without interruptions
Green LED does not light up	Sensor is faulty	If the power supply is OK, replace the sensor
Yellow LED flashes	Sensor is still ready for operation, but the operating conditions are not ideal	Check the operating conditions: Fully align the beam of light (light spot) with the object / Clean the optical surfaces / Readjust the sensitivity (potentiometer) / Check

LED indicator/fault pattern	Cause	Measures
		sensing range and adjust if necessary, <a href="#">see figure 10, page 9</a>
Yellow LED lights up, no object in the path of the beam	Distance between the sensor and the background is too short	Reduce the sensing range, <a href="#">see figure 10</a>
Object is in the path of the beam, yellow LED does not light up	Distance between the sensor and the object is too long or sensing range is set too short	increase the sensing range, take note of the distance between the sensor and the background, <a href="#">see figure 10</a>

## 8 Disassembly and disposal

The sensor must be disposed of according to the applicable country-specific regulations. Efforts should be made during the disposal process to recycle the constituent materials (particularly precious metals).

## 9 Maintenance

SICK sensors are maintenance-free.

We recommend doing the following regularly:

- Clean the external lens surfaces
- Check the screw connections and plug-in connections

No modifications may be made to devices.

Subject to change without notice. Specified product properties and technical data are not written guarantees.

## 10 Technical specifications

	GRTB18(S)-xxx1xV	GRTB18(S)-xxx3xV	GRTB18(S)-xxx2xV
Sensing range	3 ... 300 mm	3 ... 100 mm	3 ... 200 mm
Sensing range max.	3 ... 300 mm <sup>1</sup>	3 ... 100 mm <sup>1</sup>	3 ... 200 mm <sup>1</sup>
Possibility of setting	Potentiometer	No possibility of setting	No possibility of setting
Light spot diameter/distance	7 mm / 100 mm	7 mm / 100 mm	7 mm / 100 mm
Supply voltage V <sub>S</sub>	DC 10 ... 30 V <sup>2</sup>	DC 10 ... 30 V <sup>2</sup>	DC 10 ... 30 V <sup>2</sup>
Output current I <sub>max.</sub>	100 mA	100 mA	100 mA
Max. switching frequency	1,000 Hz <sup>5</sup>	1,000 Hz <sup>5</sup>	1,000 Hz <sup>5</sup>
Max. response time	< 0.5 ms <sup>6</sup>	< 0.5 ms <sup>6</sup>	< 0.5 ms <sup>6</sup>
Enclosure rating	IP67,IP68,IP69K <sup>11</sup>	IP67,IP68,IP69K <sup>11</sup>	IP67,IP68,IP69K <sup>11</sup>
Protection class	III <sup>8</sup>	III <sup>8</sup>	III <sup>8</sup>
Circuit protection	A,B,D <sup>10</sup>	A,B,D <sup>10</sup>	A,B,D <sup>10</sup>
Ambient operating temperature	-25 °C ... +55 °C	-25 °C ... +55 °C	-25 °C ... +55 °C

- 1 Tastgut mit 90 % Remission (bezogen auf Standard-Weiß DIN 5033)
- 2 Grenzwerte; Betrieb im kurzschlussgeschützten Netz max. 8 A; Restwelligkeit max. 5 V<sub>ss</sub>
- 4 Gebrauchskategorie: AC-15, DC-13 (EN 60947-1)
- 5 Mit Hell- / Dunkelverhältnis 1:1
- 6 Signallaufzeit bei ohmscher Last
- 7 gültig für Q\ auf Pin2, wenn per Software konfiguriert
- 8 Bemessungsspannung DC 50 V
- 10 A = U<sub>V</sub>-Anschlüsse verpolsicher  
 B = Ein- und Ausgänge verpolsicher  
 D = Ausgänge überstrom- und kurzschlussfest
- 11 IP68: according to EN 60529 (water depth of 10 m / 24 h).  
 IP69K: according to ISO 20653:2013-03.

# GRTB18(S)V

Rundlichtschranken

**SICK**  
Sensor Intelligence.

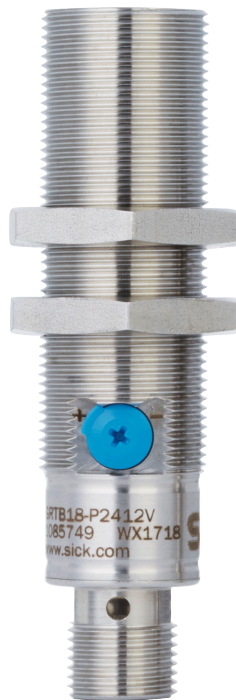

de  
en  
es  
fr  
it  
ja  
pt  
ru  
zh

### Beschriebenes Produkt

GR18 Inox  
GRTB18(S)V

### Hersteller

SICK AG  
Erwin-Sick-Str. 1  
79183 Waldkirch  
Deutschland

### Fertigungsstandort

SICK, Malaysia

### Rechtliche Hinweise

Dieses Werk ist urheberrechtlich geschützt. Die dadurch begründeten Rechte bleiben bei der Firma SICK AG. Die Vervielfältigung des Werks oder von Teilen dieses Werks ist nur in den Grenzen der gesetzlichen Bestimmungen des Urheberrechtsgesetzes zulässig. Jede Änderung, Kürzung oder Übersetzung des Werks ohne ausdrückliche schriftliche Zustimmung der Firma SICK AG ist untersagt.

Die in diesem Dokument genannten Marken sind Eigentum ihrer jeweiligen Inhaber.

© SICK AG. Alle Rechte vorbehalten.

### Originaldokument

Dieses Dokument ist ein Originaldokument der SICK AG.



## Inhalt

<b>11</b>	<b>Sicherheitshinweise.....</b>	<b>16</b>
<b>12</b>	<b>Bestimmungsgemäße Verwendung.....</b>	<b>16</b>
<b>13</b>	<b>Bedien- und Anzeigeelemente.....</b>	<b>16</b>
<b>14</b>	<b>Montage.....</b>	<b>17</b>
<b>15</b>	<b>Elektronische Installation.....</b>	<b>18</b>
<b>16</b>	<b>Inbetriebnahme.....</b>	<b>19</b>
<b>17</b>	<b>Störungsbehebung.....</b>	<b>21</b>
	17.1 Tabelle Störungsbehebung.....	21
<b>18</b>	<b>Demontage und Entsorgung.....</b>	<b>22</b>
<b>19</b>	<b>Wartung.....</b>	<b>22</b>
<b>20</b>	<b>Technische Daten.....</b>	<b>23</b>

## 11 Sicherheitshinweise

- Vor der Inbetriebnahme die Betriebsanleitung lesen.
-  Anschluss, Montage und Einstellung nur durch Fachpersonal.
- Kein Sicherheitsbauteil gemäß EU-Maschinenrichtlinie.
- Power supply: Class 2  
Enclosure type 1
- Gerät bei Inbetriebnahme vor Feuchte und Verunreinigung schützen.
- Diese Betriebsanleitung enthält Informationen, die während des Lebenszyklus des Sensors notwendig sind.

## 12 Bestimmungsgemäße Verwendung

Die GRTB18(S)V ist ein optoelektronischer Reflexions-Lichttaster (im Folgenden Sensor genannt) und wird zum optischen, berührungslosen Erfassen von Sachen, Tieren und Personen eingesetzt. Bei jeder anderen Verwendung und bei Veränderungen am Produkt verfällt jeglicher Gewährleistungsanspruch gegenüber der SICK AG.

## 13 Bedien- und Anzeigeelemente

Reflexionslichttaster mit Hintergrundausblendung.

Tabelle 6: Maßzeichnungen



Abbildung 12: Kurzbauform, Anschlussleitung



Abbildung 13: Kurzbauform, Stecker M12

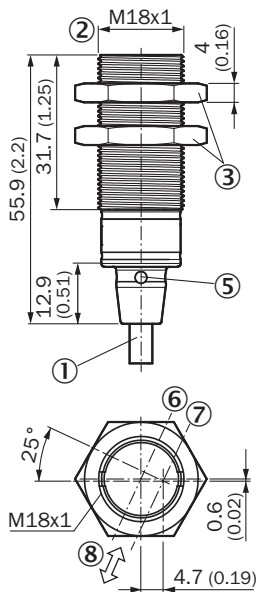

Abbildung 14: Kurzbauform, Poti, Anschlussleitung

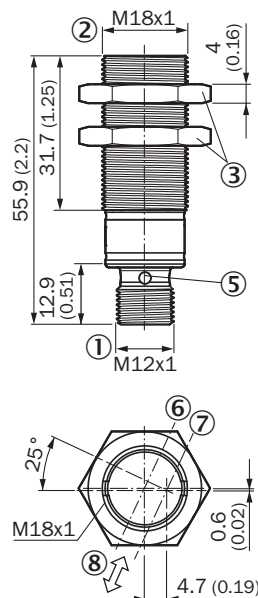

Abbildung 15: Kurzbauform, Poti, Stecker M12



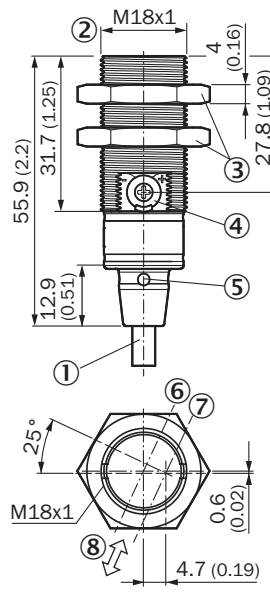

Abbildung 16: Langbauform, Anschlussleitung

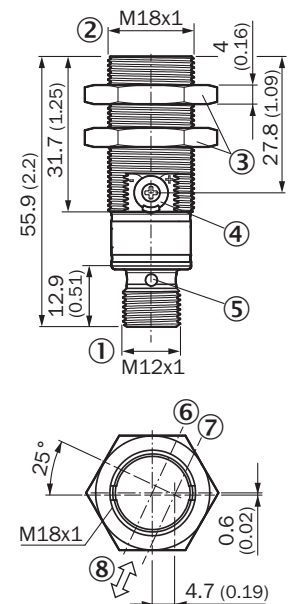

Abbildung 17: Langbauform, Stecker M12

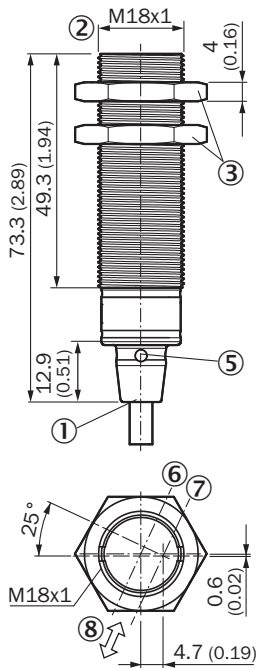

Abbildung 18: Langbauform, Poti, Anschlussleitung

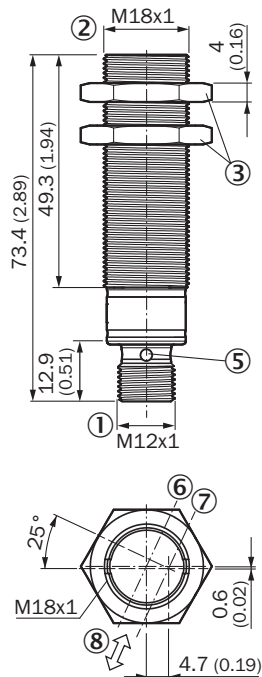

Abbildung 19: Langbauform, Poti, Stecker M12

- ① Anschluss
- ② Befestigungsgewinde M18 x 1
- ③ Befestigungsmutter (2 x); WS24, Edelstahl
- ④ Potentiometer, 270°
- ⑤ Anzeige-LED (4 x)
- ⑥ Optikachse, Empfänger
- ⑦ Optikachse, Sender
- ⑧ Vorzugsrichtung

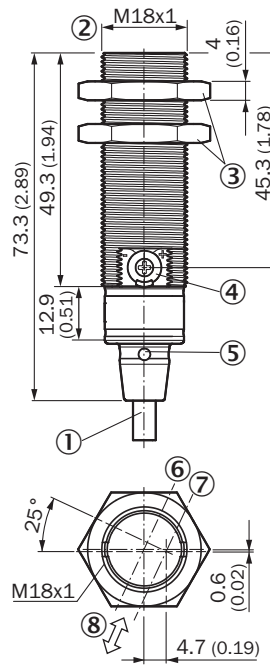

Abbildung 20: Bedienelement: Schaltabstand

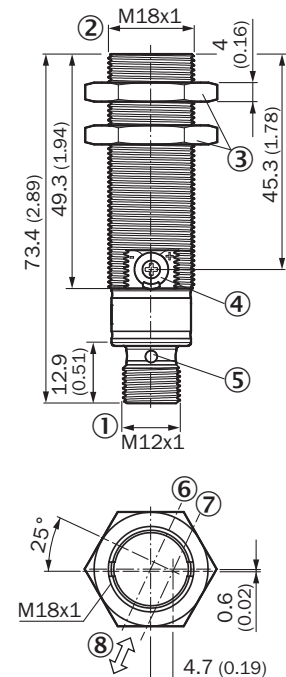
## 14 Montage

Den Sensor an einen geeigneten Befestigungswinkel montieren (siehe SICK-Zubehör-Programm).

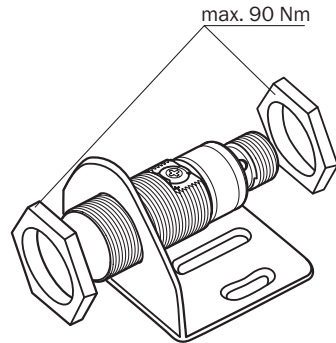

Maximal zulässiges Anzugsdrehmoment des Sensors von 90 Nm beachten.

Vorzugsrichtung des Objektes zum Sensor beachten, vgl. [Tabelle 6](#).

## 15 Elektronische Installation

Anschluss der Sensoren muss spannungsfrei ( $U_V = 0\text{ V}$ ) erfolgen. Je nach Anschlussart sind die folgenden Informationen zu beachten:

- Steckeranschluss: Pinbelegung
- Leitung: Adernfarbe

Erst nach Anschluss aller elektrischen Verbindungen die Spannungsversorgung ( $U_V > 0\text{ V}$ ) anlegen bzw. einschalten. Am Sensor leuchtet die grüne Anzeige-LED.

Erläuterungen zum Anschlussschema (Tabellen 2 und 3):

$Q / \bar{Q}$  = Schaltausgänge

n. c. = nicht angeschlossen

**DC: 10... 30 V DC, siehe „Technische Daten“, Seite 23**

Tabelle 7: DC

GRTB18(S)V	x11xxx	x13xxx	x24xxx	x23xxx
1	+ (L+)	+ (L+)	+ (L+)	+ (L+)
2	$\bar{Q}$	n. c.	$\bar{Q}$	n. c.
3	- (M)	- (M)	- (M)	- (M)
4	Q	Q	Q	Q
	 <p>1 = brn 2 = wht 3 = blu 4 = blk 0.14 mm<sup>2</sup> AWG26</p>	 <p>1 = brn - 3 = blu 4 = blk 0.14 mm<sup>2</sup> AWG26</p>		

Tabelle 8: DC

		
PNP: Q ( $\leq 100$ mA)		
NPN: Q ( $\leq 100$ mA)		
PNP: $\bar{Q}$ ( $\leq 100$ mA)		
NPN: $\bar{Q}$ ( $\leq 100$ mA)		

## 16 Inbetriebnahme

### 1 Ausrichtung

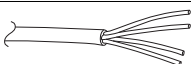
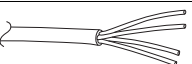
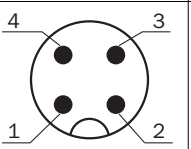
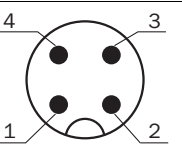
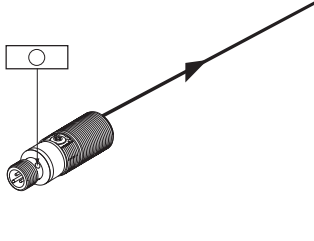
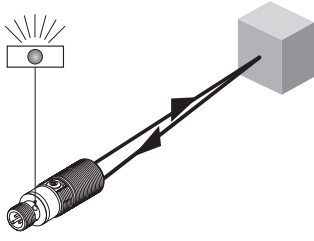
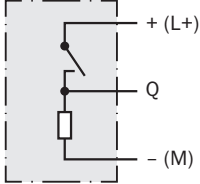
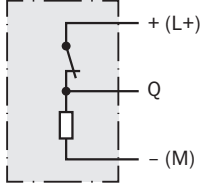
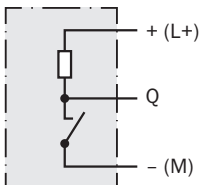
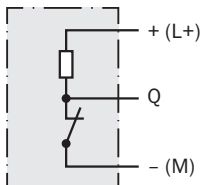
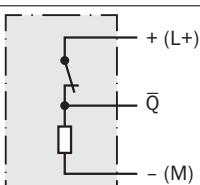
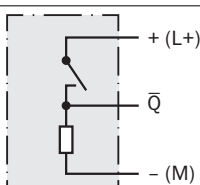
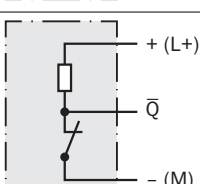
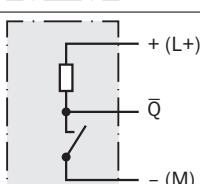
Sensor auf Objekt ausrichten. Positionierung so wählen, dass der rote Sendelichtstrahl in der Mitte des Objekts auftrifft. Es ist darauf zu achten, dass die optische Öffnung (Frontscheibe) des Sensors vollständig frei ist [siehe Abbildung].



Abbildung: Ausrichtung

### 2 Schaltabstand

Einsatzbedingungen prüfen: Schaltabstand und Distanz zum Objekt bzw. Hintergrund sowie Remissionsvermögen des Objektes mit dem zugehörigen Diagramm [siehe [Abbildung 21](#)] abgleichen ( $x$  = Schaltabstand,  $y$  = Übergangsbereich zwischen eingestelltem Schaltabstand und Ausblendung des Hintergrundes in % des Schaltabstands (Remission Objekt / Remission Hintergrund)). Remission: 6 % = schwarz ①, 18 % = grau ②, 90 % = weiß ③ (bezogen auf Standardweiß nach DIN 5033). Wir empfehlen, die Einstellung mit einem Objekt von niedriger Remission vorzunehmen.

Die minimale Distanz (=  $y$ ) für die Hintergrundausbldung kann aus dem Diagramm [siehe [Abbildung 21](#) ①] wie folgt ermittelt werden:

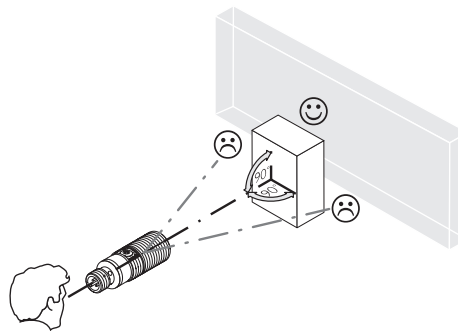
Beispiel:  $x = 150$  mm,  $y = 20 \Rightarrow 20\%$  von 150 mm = 30 mm. D. h. der Hintergrund wird ab einer Distanz von > 180 mm vom Sensor ausgeblendet.

Mindestabstand in mm ( $y$ ) zwischen eingestelltem Schaltabstand und Hintergrund (weiß, 90%) in %-Abhängigkeit des Schaltabstandes

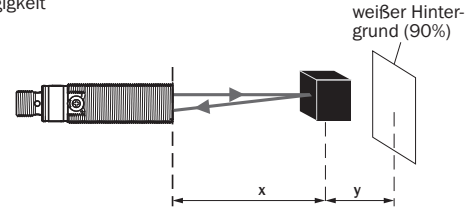
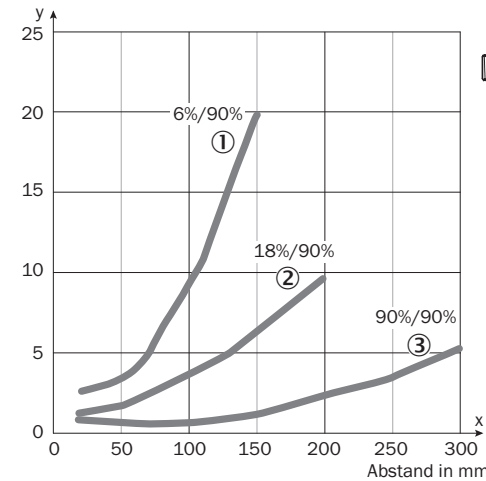

Beispiel:  
Schaltabstand auf Schwarz, 6%,  
 $x = 100$  mm,  $y = (10\%$  von 100 mm) = 10 mm

- ① Schaltabstand auf Schwarz, 6 % Remission
- ② Schaltabstand auf Grau, 18 % Remission
- ③ Schaltabstand auf Weiß, 90 % Remission

Abbildung 21: Schaltabstand bis 300 mm

Zur Überprüfung der Funktion [Abbildung 22](#) und Tabelle 3 heranziehen. Verhält sich der Schaltausgang nicht gemäß Tabelle 3, Einsatzbedingungen prüfen. Siehe Abschnitt Fehlerdiagnose.

### 3 Einstellung Schaltabstand

Sensor ohne Einstellmöglichkeit: Sensor ist eingestellt und betriebsbereit.

Mit dem Potentiometer (Art: 270°) wird der Schaltabstand eingestellt. Drehung nach rechts: Erhöhung des Schaltabstandes, Drehung nach links: Verringerung des Schaltabstandes. Wir empfehlen, den Schaltabstand in das Objekt zu legen, z. B. [siehe Tabelle 9](#). Nachdem der Schaltabstand eingestellt worden ist, das Objekt aus dem Strahlengang entfernen, der Hintergrund wird dabei ausgeblendet und der Schaltausgang ändert sich [[siehe Tabelle 8](#)].

Tabelle 9: Einstellung Schaltabstand

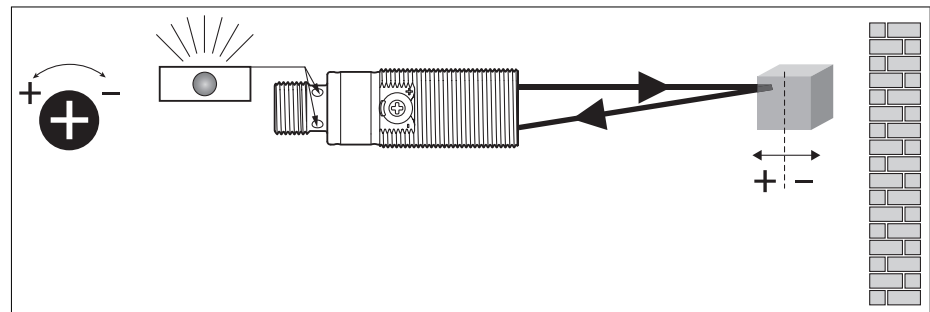

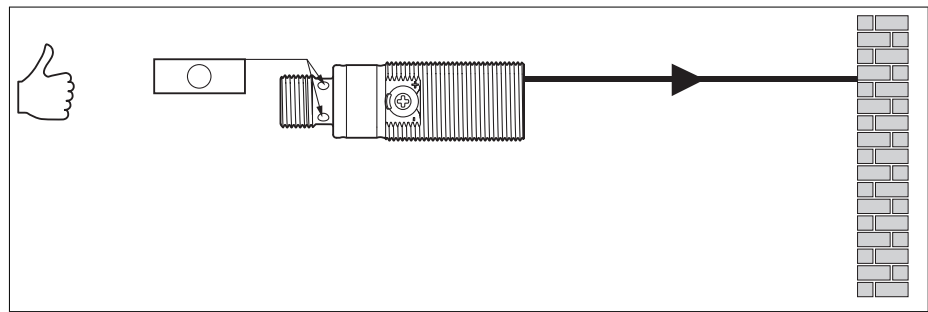

Sensor ist eingestellt und betriebsbereit.



Abbildung 22: Detektion

## 17 Störungsbehebung

Tabelle Störungsbehebung zeigt, welche Maßnahmen durchzuführen sind, wenn die Funktion des Sensors nicht mehr gegeben ist.

### 17.1 Tabelle Störungsbehebung

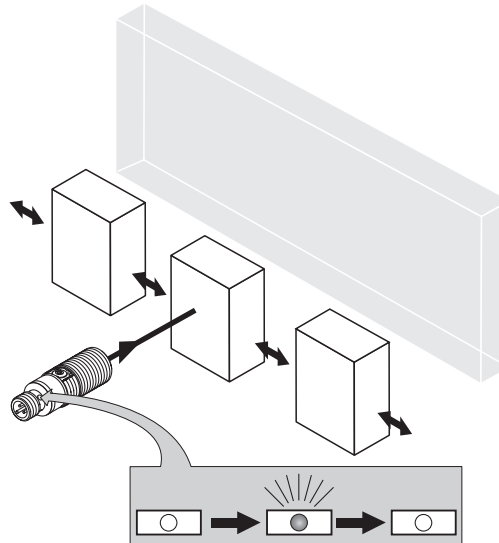
Tabelle 10: Störungsbehebung

Anzeige-LED / Fehlerbild	Ursache	Maßnahme
grüne LED leuchtet nicht	keine Spannung oder Spannung unterhalb der Grenzwerte	Spannungsversorgung prüfen, den gesamten elektrischen Anschluss prüfen (Leitungen und Steckerverbindungen)
grüne LED leuchtet nicht	Spannungsunterbrechungen	Sicherstellen einer stabilen Spannungsversorgung ohne Unterbrechungen
grüne LED leuchtet nicht	Sensor ist defekt	Wenn Spannungsversorgung in Ordnung ist, dann Sensor austauschen
gelbe LED blinkt	Sensor ist noch betriebsbereit, aber die Betriebsbedingungen sind nicht optimal	Betriebsbedingungen prüfen: Lichtstrahl (Lichtfleck) vollständig auf das Objekt ausrichten / Reinigung der optischen Flächen / Empfindlichkeit (Potentiometer) neu ein-

Anzeige-LED / Fehlerbild	Ursache	Maßnahme
		stellen / Schaltabstand überprüfen und ggf. anpassen, <a href="#">siehe Abbildung 21, Seite 20</a>
gelbe LED leuchtet, kein Objekt im Strahlengang	Abstand zwischen Sensor und Hintergrund ist zu gering	Schaltabstand verringern, <a href="#">siehe Abbildung 21</a>
Objekt ist im Strahlengang, gelbe LED leuchtet nicht	Abstand zwischen Sensor und Objekt ist zu groß oder Schaltabstand ist zu gering eingestellt	Schaltabstand vergrößern, Abstand zwischen Sensor und Hintergrund beachten, <a href="#">siehe Abbildung 21</a>

## 18 Demontage und Entsorgung

Die Entsorgung des Sensors hat gemäß den länderspezifisch anwendbaren Vorschriften zu erfolgen. Für die enthaltenen Wertstoffe (insbesondere Edelmetalle) ist im Rahmen der Entsorgung eine Verwertung anzustreben.

## 19 Wartung

SICK-Sensoren sind wartungsfrei.

Wir empfehlen, in regelmäßigen Abständen

- die optischen Grenzflächen zu reinigen
- Verschraubungen und Steckverbindungen zu überprüfen

Veränderungen an Geräten dürfen nicht vorgenommen werden.

Irrtümer und Änderungen vorbehalten. Angegebene Produkteigenschaften und technische Daten stellen keine Garantieerklärung dar.

## 20 Technische Daten

	GRTB18(S)-xxx1xV	GRTB18(S)-xxx3xV	GRTB18(S)-xxx2xV
Schaltabstand	3 ... 300 mm	3 ... 100 mm	3 ... 200 mm
Schaltabstand max.	3 ... 300 mm <sup>1</sup>	3 ... 100 mm <sup>1</sup>	3 ... 200 mm <sup>1</sup>
Einstellmöglichkeit	Potentiometer	keine Einstellmöglichkeit	keine Einstellmöglichkeit
Lichtfleckdurchmesser/Entfernung	7 mm / 100 mm	7 mm / 100 mm	7 mm / 100 mm
Versorgungsspannung $U_V$	DC 10 ... 30 V <sup>2</sup>	DC 10 ... 30 V <sup>2</sup>	DC 10 ... 30 V <sup>2</sup>
Ausgangsstrom $I_{max}$	100 mA	100 mA	100 mA
Schaltfolge max.	1,000 Hz <sup>5</sup>	1,000 Hz <sup>5</sup>	1,000 Hz <sup>5</sup>
Ansprechzeit max.	< 0.5 ms <sup>6</sup>	< 0.5 ms <sup>6</sup>	< 0.5 ms <sup>6</sup>
Schutzart	IP67,IP68,IP69K <sup>11</sup>	IP67,IP68,IP69K <sup>11</sup>	IP67,IP68,IP69K <sup>11</sup>
Schutzklasse	III <sup>8</sup>	III <sup>8</sup>	III <sup>8</sup>
Schutzschaltungen	A,B,D <sup>10</sup>	A,B,D <sup>10</sup>	A,B,D <sup>10</sup>
Betriebsumgebungstemperatur	-25 °C ... +55 °C	-25 °C ... +55 °C	-25 °C ... +55 °C

- 1 Tastgut mit 90 % Remission (bezogen auf Standard-Weiß DIN 5033)
- 2 Grenzwerte; Betrieb im kurzschlussgeschützten Netz max. 8 A; Restwelligkeit max. 5 V<sub>ss</sub>
- 4 Gebrauchskategorie: AC-15, DC-13 (EN 60947-1)
- 5 Mit Hell- / Dunkelverhältnis 1:1
- 6 Signallaufzeit bei ohmscher Last
- 7 gültig für Q\ auf Pin2, wenn per Software konfiguriert
- 8 Bemessungsspannung DC 50 V
- 10 A = U<sub>V</sub>-Anschlüsse verpolsicher  
B = Ein- und Ausgänge verpolsicher  
D = Ausgänge überstrom- und kurzschlussfest
- 11 IP68: Nach EN 60529 (10 m Wassertiefe / 24 h).  
IP69K: Nach ISO 20653:2013-03.

# GRTB18(S)V

Capteurs photoélectriques cylindriques

**SICK**  
Sensor Intelligence.

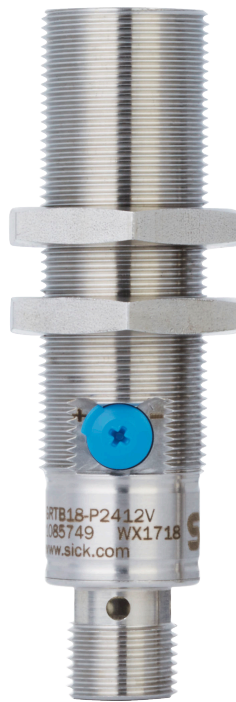

de  
en  
es  
fr  
it  
ja  
pt  
ru  
zh



---

**Produit décrit**

GR18 Inox  
GRTB18(S)V

**Fabricant**

SICK AG  
Erwin-Sick-Straße 1  
79183 Waldkirch  
Allemagne

**Site de fabrication**

SICK, Malaisie

**Remarques juridiques**

Cet ouvrage est protégé par les droits d'auteur. Les droits établis restent dévolus à la société SICK AG. La reproduction de l'ouvrage, même partielle, n'est autorisée que dans le cadre légal prévu par la loi sur les droits d'auteur. Toute modification, tout abrègement ou toute traduction de l'ouvrage est interdit sans l'accord écrit exprès de la société SICK AG.

Les marques citées dans ce document sont la propriété de leurs détenteurs respectifs.

© SICK AG. Tous droits réservés.

**Document original**

Ce document est un document original de SICK AG.



## Contenu

21	Instructions de sécurité.....	27
22	Utilisation conforme.....	27
23	Éléments de commande et d'affichage.....	27
24	Montage.....	28
25	Installation électronique.....	29
26	Mise en service.....	30
27	Élimination des défauts.....	32
	27.1 Tableau Suppression des défaillances.....	32
28	Démontage et mise au rebut.....	33
29	Maintenance.....	33
30	Caractéristiques techniques.....	34

## 21 Instructions de sécurité

- Lire la notice d'instruction avant la mise en service.
-  Confier le raccordement, le montage et le réglage uniquement au personnel qualifié.
- Il ne s'agit pas d'un composant de sécurité au sens de la directive machines CE.
- Power supply: Class 2  
Enclosure type 1
- Protéger l'appareil contre l'humidité et les impuretés lors de la mise en service.
- Cette notice d'instruction contient des informations nécessaires pendant toute le cycle de vie du capteur.

## 22 Utilisation conforme

GRTB18(S)V est un détecteur à réflexion directe optoélectronique (appelé capteur dans ce document) qui permet la détection optique sans contact d'objets, d'animaux et de personnes. Toute autre utilisation ou modification du produit annule la garantie de SICK AG.

## 23 Éléments de commande et d'affichage

Détecteur à réflexion directe avec élimination d'arrière-plan

Tableau 11: Plans cotés

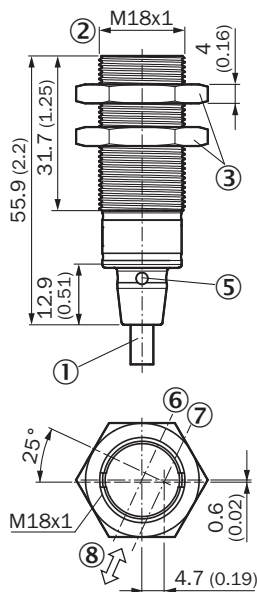

Illustration 23: Forme courte, câble de raccordement

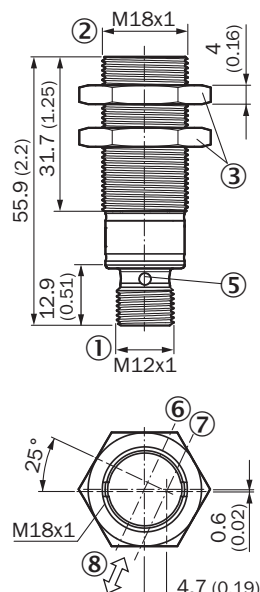

Illustration 24: Forme courte, connecteur mâle M12

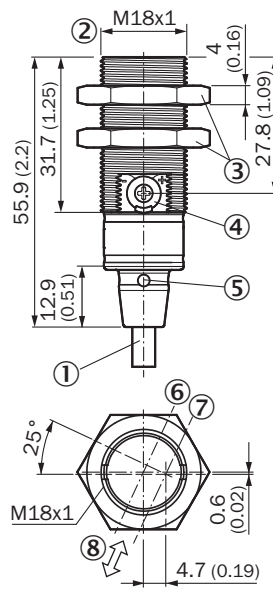

Illustration 25: Forme courte, potentiomètre, câble de raccordement

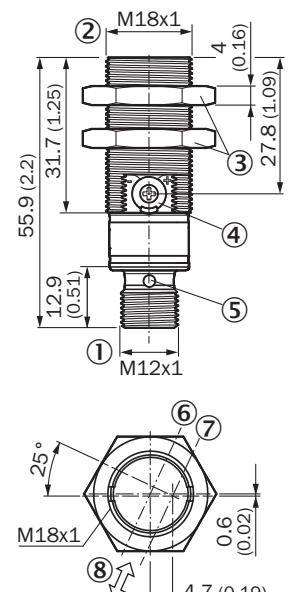

Illustration 26: Forme courte, potentiomètre, connecteur mâle M12

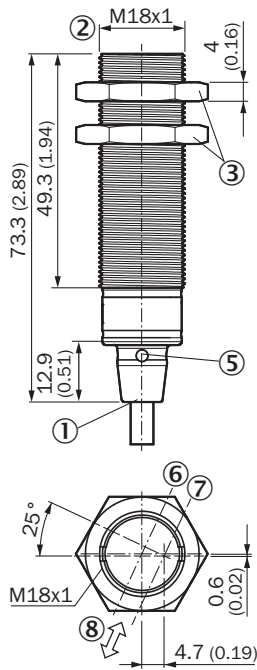

Illustration 27: Forme longue, câble de raccordement

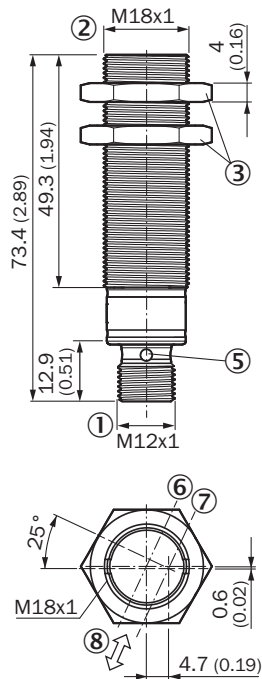

Illustration 28: Forme longue, connecteur mâle M12

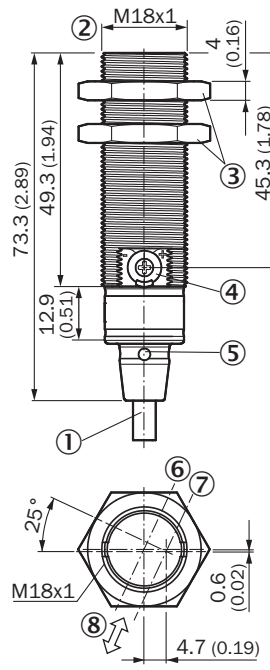

Illustration 29: Forme longue, potentiomètre, câble de raccordement

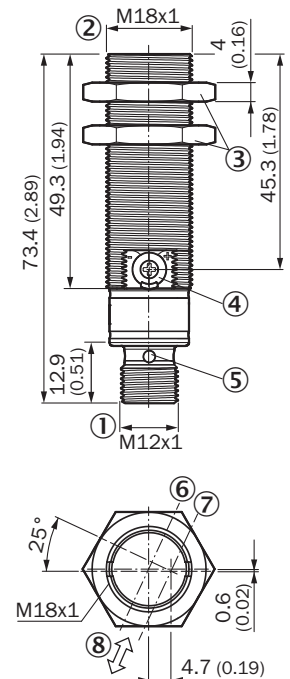

Illustration 30: Forme longue, potentiomètre, connecteur mâle M12

- ① Raccordement
- ② Filetage de fixation M18 x 1
- ③ Écrou de fixation (2 x) ; WS24, acier inoxydable
- ④ Potentiomètre, 270°
- ⑤ LED témoin (4 x)
- ⑥ Axe optique, récepteur
- ⑦ Axe optique, émetteur
- ⑧ Sens recommandé

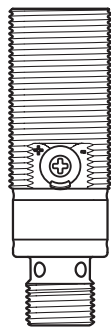
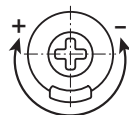
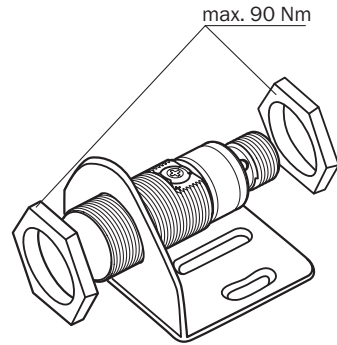

Illustration 31: Éléments de commande : Distance de commutation

## 24 Montage

Montez le capteur sur une équerre de fixation adaptée (voir la gamme d’accessoires SICK).



Respecter le couple de serrage maximum autorisé du capteur de 90 Nm  
 Tenir compte de la direction préférentielle de l'objet par rapport au capteur, voir [tableau 11](#).

## 25 Installation électronique

Le raccordement des capteurs doit s'effectuer hors tension ( $U_v = 0\text{ V}$ ). Selon le mode de raccordement, respecter les informations suivantes :

- Raccordement du connecteur : affectation des broches
- Câble : couleur des fils

Après avoir terminé tous les raccordements électriques, appliquer ou activer l'alimentation électrique ( $U_v > 0\text{ V}$ ). La LED verte s'allume sur le capteur.

Explications du schéma de raccordement (tableaux 2 et 3) :

Q /  $\bar{Q}$  = sorties de commutation

n. c. = non connecté

**CC : 10 ... 30 V CC, voir „Caractéristiques techniques“, page 34**

Tableau 12: CC

GRTB18(S)V	x11xxx	x13xxx	x24xxx	x23xxx
1	+ (L+)	+ (L+)	+ (L+)	+ (L+)
2	$\bar{Q}$	n. c.	$\bar{Q}$	n. c.
3	- (M)	- (M)	- (M)	- (M)
4	Q	Q	Q	Q
	 1 = brn (marron) 2 = wht (blanc) 3 = blu (bleu) 4 = blk (noir) 0,14 mm <sup>2</sup> AWG26	 1 = brn (marron) - 3 = blu (bleu) 4 = blk (noir) 0,14 mm <sup>2</sup> AWG26		

Tableau 13: CC

		
PNP : Q ( $\leq 100$ mA)		
NPN : Q ( $\leq 100$ mA)		
PNP : $\bar{Q}$ ( $\leq 100$ mA)		
NPN : $\bar{Q}$ ( $\leq 100$ mA)		

## 26 Mise en service

### 1 Alignement

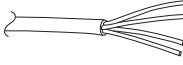
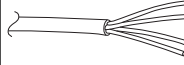
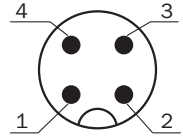
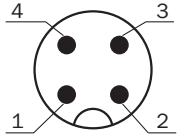
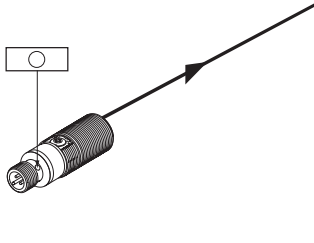
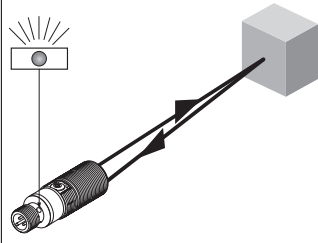
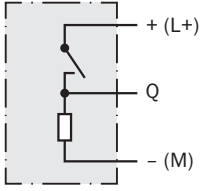
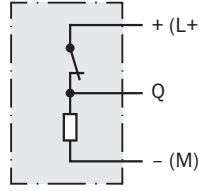
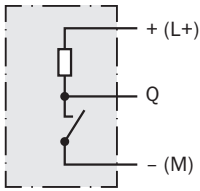
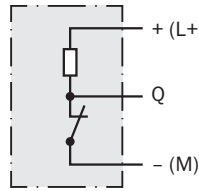
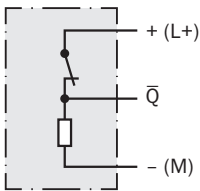
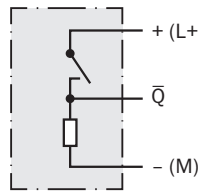
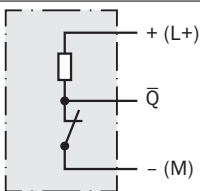
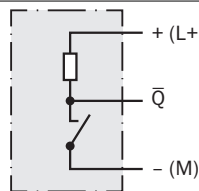
Aligner le capteur sur l'objet. Choisir la position de sorte que le faisceau lumineux émis rouge touche l'objet en plein centre. S'assurer que l'ouverture optique (vitre frontale) du capteur est parfaitement dégagée [voir illustration].

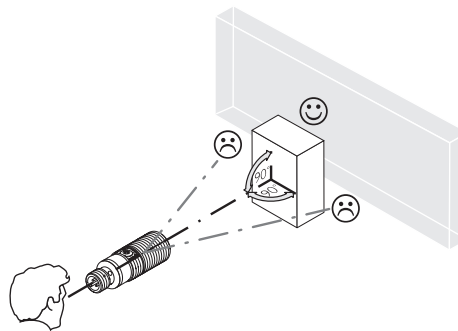

Illustration: Alignement

### 2 Distance de commutation

Vérifier les conditions d'utilisation : comparer la portée et la distance à l'objet ou à l'arrière-plan et les caractéristiques de réflectance avec le diagramme correspondant [voir illustration 32] (x = portée, y = zone de transition entre la portée réglée et le masquage de l'arrière-plan en % de la portée (réflectance de l'objet / réflectance de l'arrière-plan)).  
 Réflectance : 6 % = noir ①, 18 % = gris ②, 90 % = blanc ③ (par rapport au blanc standard selon DIN 5033). Nous recommandons de procéder au réglage avec un objet peu réfléchissant.

La distance minimale (=y) pour l'élimination d'arrière-plan peut être calculée à partir du diagramme [ voir illustration 32 ①] comme suit :

Exemple : x = 150 mm, y = 20 => 20 % de 150 mm = 30 mm. C'est à dire que l'arrière-plan est masqué à partir d'une distance du capteur > 180 .

Mindestabstand in mm (y) zwischen eingestelltem Schaltabstand und Hintergrund (weiß, 90%) in %-Abhängigkeit des Schaltabstandes

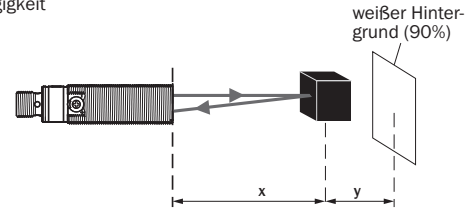
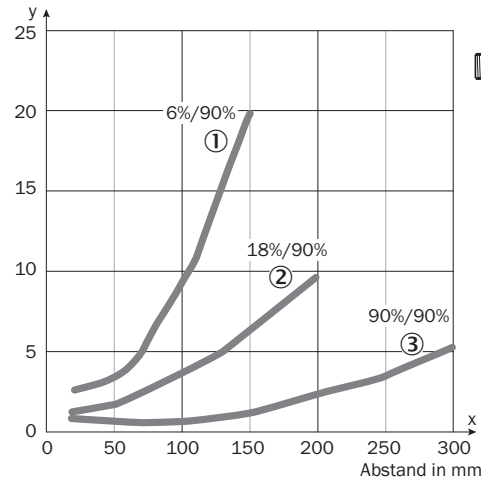

Beispiel:  
 Schaltabstand auf Schwarz, 6%,  
 x = 100 mm, y = (10% von 100 mm) = 10 mm

- ① Schaltabstand auf Schwarz, 6 % Remission
- ② Schaltabstand auf Grau, 18 % Remission
- ③ Schaltabstand auf Weiß, 90 % Remission

Illustration 32: Distance de commutation jusqu'à 300 mm

Pour vérifier le fonctionnement, utiliser illustration 33 et le tableau 3. Si la sortie de commutation ne se comporte pas comme indiqué dans le tableau 3, vérifier les conditions d'utilisation. Voir la section consacrée au diagnostic.

### 3 Réglage distance de commutation

Capteur sans possibilité de réglage : le capteur est réglé et prêt à l'emploi.

La distance de commutation se règle avec le potentiomètre (réf. : 270°). Rotation vers la droite : augmentation de la distance de commutation, rotation vers la gauche : réduction de la distance de commutation. Nous recommandons de régler la distance de commutation sur l'objet, p. ex. voir tableau 14. Après le réglage de la distance de commutation, extraire l'objet de la trajectoire du faisceau, ce qui élimine l'arrière-plan et modifie la sortie de commutation [voir tableau 13].

Tableau 14: Réglage distance de commutation

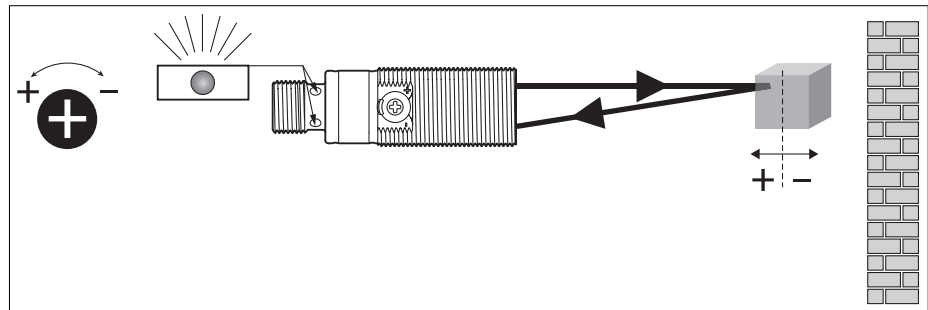

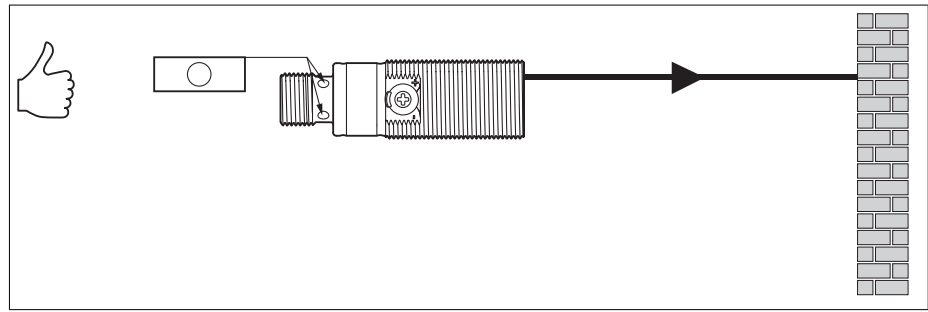

Le capteur est réglé et prêt à l'emploi.

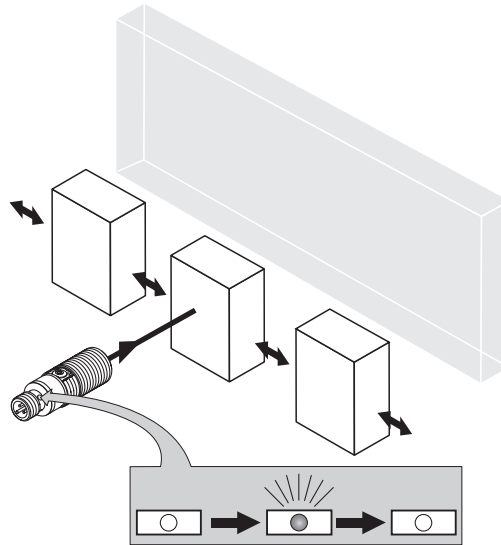

Illustration 33: Détection

## 27 Élimination des défauts

Le tableau Élimination des défauts présente les mesures à appliquer si le capteur ne fonctionne plus.

### 27.1 Tableau Suppression des défaillances

Tableau 15: Élimination des défauts

LED d'état / image du défaut	Cause	Mesure
La LED verte ne s'allume pas	Pas de tension ou tension inférieure aux valeurs limites	Contrôler l'alimentation électrique, contrôler tous les branchements électriques (câbles et connexions)
La LED verte ne s'allume pas	Coupures d'alimentation électrique	S'assurer que l'alimentation électrique est stable et ininterrompue
La LED verte ne s'allume pas	Le capteur est défectueux	Si l'alimentation électrique est en bon état, remplacer le capteur
La LED jaune clignote	Le capteur est encore opérationnel, mais les conditions d'utilisation ne sont pas idéales	Vérifier les conditions d'utilisation : Diriger le faisceau lumineux (spot lumineux) entièrement sur l'objet / Nettoyage des surfaces optiques / Régler à nouveau la



LED d'état / image du défaut	Cause	Mesure
		sensibilité (potentiomètre) / Contrôler la distance de commutation et éventuellement l'adapter, voir <a href="#">illustration 32</a> , <a href="#">page 31</a>
La LED jaune s'allume, pas d'objet dans la trajectoire du faisceau	La distance entre le capteur et l'arrière-plan est trop faible	Réduire la distance de commutation, voir <a href="#">illustration 32</a>
L'objet est dans la trajectoire du faisceau, la LED jaune ne s'allume pas	La distance entre le capteur et l'objet est trop grande ou la portée est trop faible	Augmenter la distance de commutation, tenir compte de la distance entre le capteur et l'arrière-plan, voir <a href="#">illustration 32</a>

## 28 Démontage et mise au rebut

La mise au rebut du capteur doit respecter la réglementation nationale en vigueur. Dans le cadre de la mise au rebut, veiller à recycler les matériaux (notamment les métaux précieux).

## 29 Maintenance

Les capteurs SICK ne nécessitent aucune maintenance.

Nous vous recommandons de procéder régulièrement

- au nettoyage des surfaces optiques
- au contrôle des vissages et des connexions enfichables

Ne procéder à aucune modification sur les appareils.

Sujet à modification sans préavis. Les caractéristiques du produit et techniques fournies ne sont pas une déclaration de garantie.

## 30 Caractéristiques techniques

	GRTB18(S)-xxx1xV	GRTB18(S)-xxx3xV	GRTB18(S)-xxx2xV
Distance de commutation	3 ... 300 mm	3 ... 100 mm	3 ... 200 mm
Portée max.	3 ... 300 mm <sup>1</sup>	3 ... 100 mm <sup>1</sup>	3 ... 200 mm <sup>1</sup>
Possibilité de réglage	Potentiomètre	Sans possibilité de réglage	Sans possibilité de réglage
Diamètre spot / distance	7 mm / 100 mm	7 mm / 100 mm	7 mm / 100 mm
Tension d'alimentation U <sub>V</sub>	DC 10 ... 30 V <sup>2</sup>	DC 10 ... 30 V <sup>2</sup>	DC 10 ... 30 V <sup>2</sup>
Courant de sortie I <sub>max.</sub>	100 mA	100 mA	100 mA
Commutation max.	1,000 Hz <sup>5</sup>	1,000 Hz <sup>5</sup>	1,000 Hz <sup>5</sup>
Temps de réponse max.	< 0.5 ms <sup>6</sup>	< 0.5 ms <sup>6</sup>	< 0.5 ms <sup>6</sup>
Indice de protection	IP67,IP68,IP69K <sup>11</sup>	IP67,IP68,IP69K <sup>11</sup>	IP67,IP68,IP69K <sup>11</sup>
Classe de protection	III <sup>8</sup>	III <sup>8</sup>	III <sup>8</sup>
Protections électriques	A,B,D <sup>10</sup>	A,B,D <sup>10</sup>	A,B,D <sup>10</sup>
Température de service	-25 °C ... +55 °C	-25 °C ... +55 °C	-25 °C ... +55 °C

- 1 Tastgut mit 90 % Remission (bezogen auf Standard-Weiß DIN 5033)  
2 Grenzwerte; Betrieb im kurzschlussgeschützten Netz max. 8 A; Restwelligkeit max. 5 V<sub>ss</sub>  
4 Gebrauchskategorie: AC-15, DC-13 (EN 60947-1)  
5 Mit Hell- / Dunkelverhältnis 1:1  
6 Signallaufzeit bei ohmscher Last  
7 gültig für Q\ auf Pin2, wenn per Software konfiguriert  
8 Bemessungsspannung DC 50 V  
10 A = U<sub>V</sub>-Anschlüsse verpolsicher  
B = Ein- und Ausgänge verpolsicher  
D = Ausgänge überstrom- und kurzschlussfest  
11 IP68 : selon EN 60529 (profondeur d'eau 10 m / 24 h).  
IP69K : selon ISO 20653:2013-03.

# GRTB18(S)V

Barreira de luz cilíndrica

**SICK**  
Sensor Intelligence.

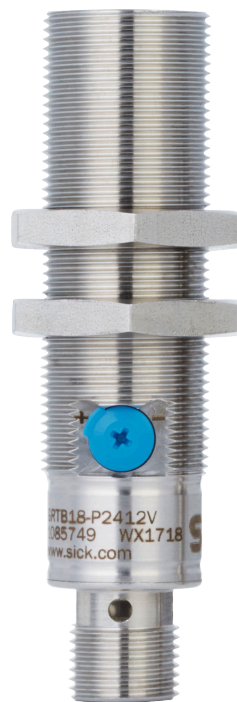

de  
en  
es  
fr  
it  
ja  
pt  
ru  
zh

---

**Produto descrito**

GR18 Inox  
GRTB18(S)V

**Fabricante**

SICK AG  
Erwin-Sick-Str. 1  
79183 Waldkirch  
Alemanha

**Local de fabricação**

SICK, Malásia

**Notas legais**

Reservados os direitos autorais do presente documento. Todos os direitos permanecem em propriedade da empresa SICK AG. A reprodução total ou parcial desta obra só é permitida dentro dos limites regulamentados pela Lei de Direitos Autorais. É proibido alterar, resumir ou traduzir esta obra sem a autorização expressa e por escrito da SICK AG.

As marcas citadas neste documento são de propriedade de seus respectivos proprietários.

© SICK AG. Todos os direitos reservados

**Documento original**

Este é um documento original da SICK AG.



## Índice

31	Avisos de segurança.....	38
32	Especificações de uso.....	38
33	Elementos de comando e indicação.....	38
34	Montagem.....	39
35	Instalação elétrica.....	40
36	Colocação em operação.....	41
37	Eliminação de falhas.....	43
	37.1 Tabela de eliminação de falhas.....	43
38	Desmontagem e descarte.....	44
39	Manutenção.....	44
40	Dados técnicos.....	45

### 31 Avisos de segurança

- Ler o manual de instruções antes da colocação em operação.
-  A conexão, a montagem e o ajuste devem ser executados somente por pessoal técnico qualificado.
- Este não é um componente de segurança conforme a Diretriz de Máquinas Europeia.
- Power supply: Class 2 Enclosure type 1
- Durante a colocação em operação, manter o aparelho protegido contra impurezas e umidade.
- Este manual de instruções contém informações necessárias para toda a vida útil do sensor.

### 32 Especificações de uso

O GRTB18(S)V é um sensor fotoelétrico de proximidade utilizado para a detecção óptica, sem contato, de objetos, animais e pessoas. Qualquer utilização diferente ou alterações do produto ocasionam a perda da garantia da SICK AG.

### 33 Elementos de comando e indicação

Sensor fotoelétrico de reflexão com supressão do fundo

Tabela 16: Desenhos dimensionais



Figura 34: Forma construtiva curta, cabo de conexão



Figura 35: Forma construtiva curta, conector M12

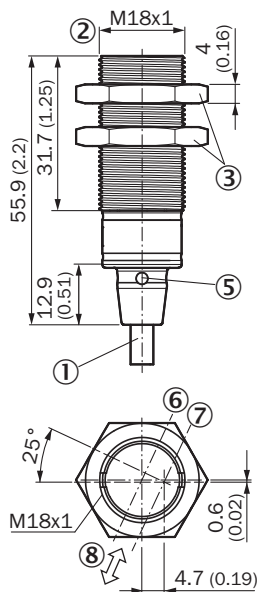

Figura 36: Forma construtiva curta, potenciômetro, cabo de conexão

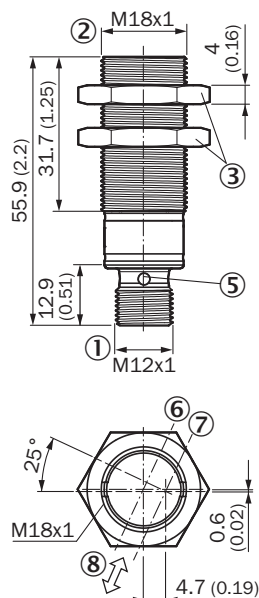

Figura 37: Forma construtiva curta, potenciômetro, conector M12

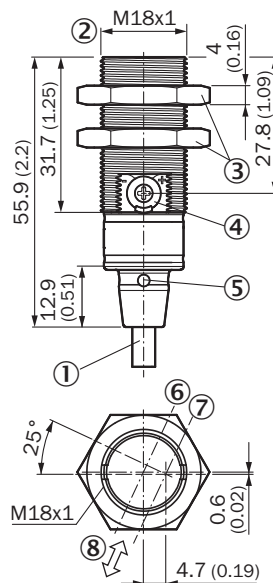

Figura 38: Forma construtiva longa, cabo de conexão

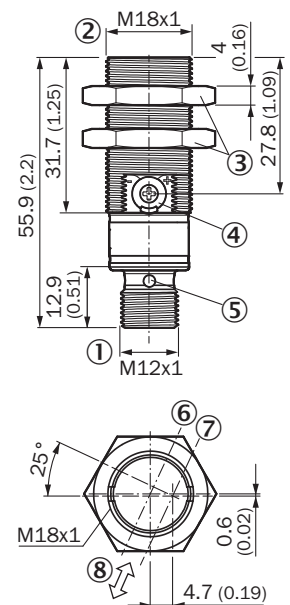

Figura 39: Forma construtiva longa, conector M12

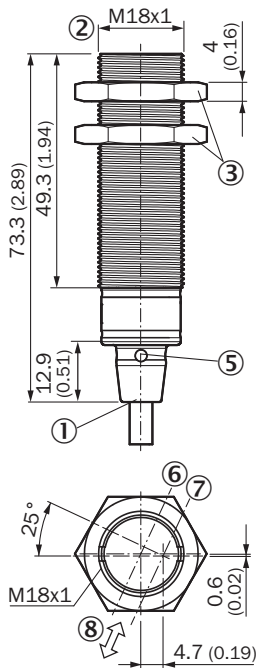

Figura 40: Forma construtiva longa, potenciômetro, cabo de conexão

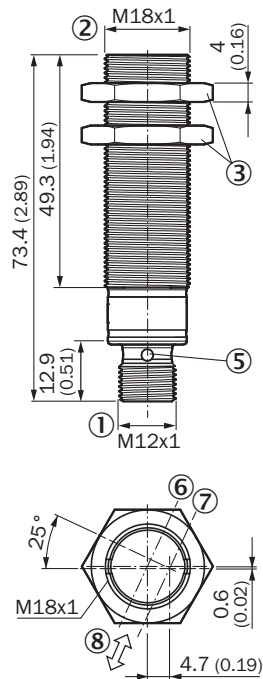

Figura 41: Forma construtiva longa, potenciômetro, conector M12

- ① Conexão
- ② Rosca de fixação M18 x 1
- ③ Porca de fixação (2 x); WS24, aço inoxidável
- ④ Potenciômetro, 270°
- ⑤ LED indicador (4 x)
- ⑥ Eixo do sistema óptico, receptor
- ⑦ Eixo do sistema óptico, emissor
- ⑧ Direção preferencial

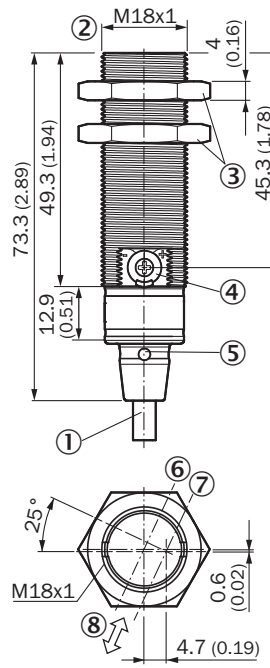

Figura 42: Elemento de comando: distância de comutação

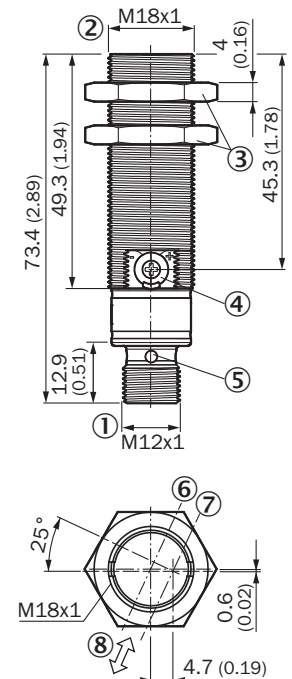
## 34 Montagem

Montar o sensor e o refletor em uma cantoneira de fixação adequada (ver a linha de acessórios SICK).

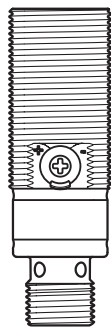
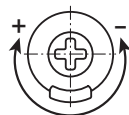
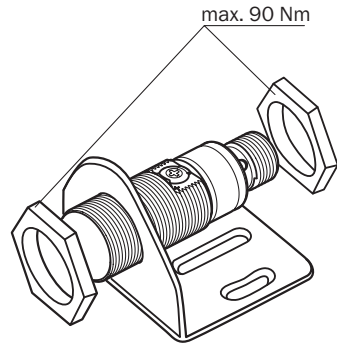

Observar o torque de aperto máximo permitido de 90 Nm para o sensor.  
 Observar a direção preferencial do objeto em relação ao sensor, cp. [tabela 16](#).

## 35 Instalação elétrica

A conexão dos sensores deve ser realizada em estado desenergizado ( $U_V = 0\text{ V}$ ). Conforme o tipo de conexão, devem ser observadas as seguintes informações:

- Conector: Pin-out
- Cabo: Cor dos fios

Instalar ou ligar a alimentação de tensão ( $U_V > 0\text{ V}$ ) somente após a conexão de todas as conexões elétricas. O indicador LED verde está aceso no sensor.

Explicações relativas ao esquema de conexões (tabelas 2 e 3):

Q /  $\bar{Q}$  = saídas de comutação

n. c. = não conectado

**CC: 10 ... 30 V CC, ver „Dados técnicos“, página 45**

Tabela 17: CC

GRTB18(S)V	x11xxx	x13xxx	x24xxx	x23xxx
1	+ (L+)	+ (L+)	+ (L+)	+ (L+)
2	$\bar{Q}$	n. c.	$\bar{Q}$	n. c.
3	- (M)	- (M)	- (M)	- (M)
4	Q	Q	Q	Q
	 <p>1 = brn                  2 = wht                  3 = blu                  4 = blk                  0,14 mm<sup>2</sup>                  AWG26</p>	 <p>1 = brn                  -                  3 = blu                  4 = blk                  0,14 mm<sup>2</sup>                  AWG26</p>		



Tabela 18: CC

		
PNP: Q ( $\leq 100$ mA)		
NPN: Q ( $\leq 100$ mA)		
PNP: $\bar{Q}$ ( $\leq 100$ mA)		
NPN: $\bar{Q}$ ( $\leq 100$ mA)		

## 36 Colocação em operação

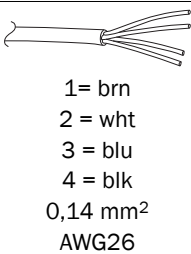
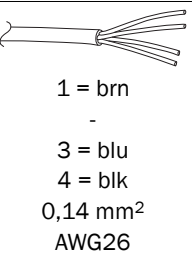
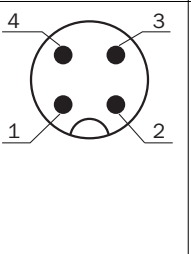
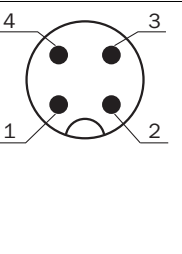
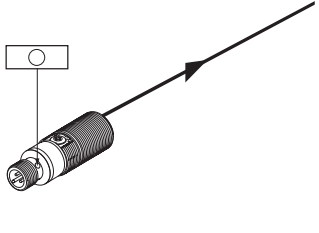
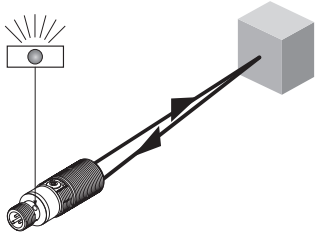
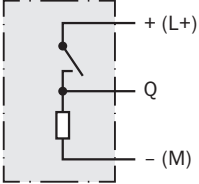
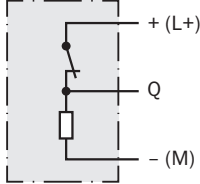
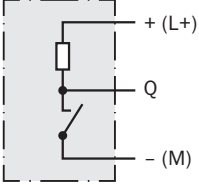
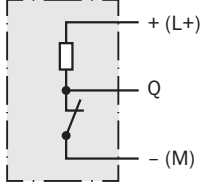
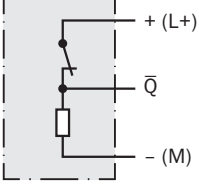
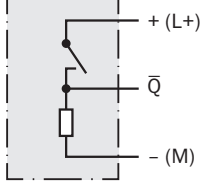
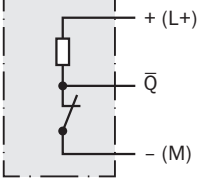
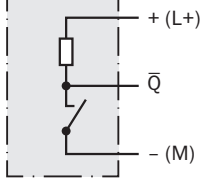
### 1 Alinhamento

Alinhar o sensor ao objeto. Selecionar o posicionamento de forma que o feixe da luz de emissão vermelha incida sobre o centro do objeto. Certificar-se de que a abertura óptica (vidro frontal) do sensor esteja completamente livre [ver figura].



Figura: Alinhamento

### 2 Distância de comutação

Verificar as condições de uso: equiparar a distância de comutação e distância até o objeto ou plano de fundo, bem como a refletividade do objeto, com o respectivo diagrama [ver figura 43] (x = distância de comutação, y = área de transição entre a distância de comutação ajustada e a supressão do fundo em % da distância de comutação (luminescência do objeto /luminescência do fundo)). Luminescência: 6% = preto ①, 18% = cinza ②, 90% = branco ③ (com base no padrão branco da norma DIN 5033). Recomendamos efetuar o ajuste com um objeto de baixa luminescência.

A distância mínima (= y) para a supressão do fundo pode ser determinada com base no diagrama [ ver figura 43 ①] como a seguir:

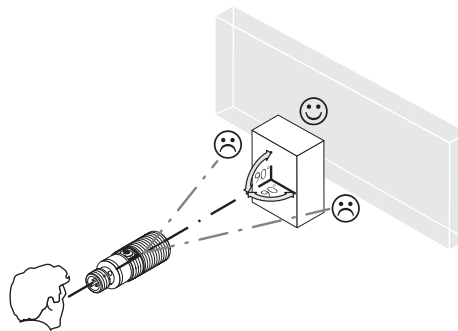
Exemplo: x = 150 mm, y = 20 => 20% von 150 mm = 30 mm. Isto significa, que o sensor suprime o plano de fundo a partir de uma distância > 180 mm.

Mindestabstand in mm (y) zwischen eingestelltem Schaltabstand und Hintergrund (weiß, 90%) in %-Abhängigkeit des Schaltabstandes

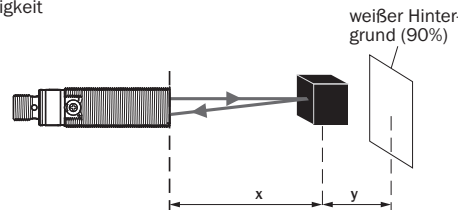
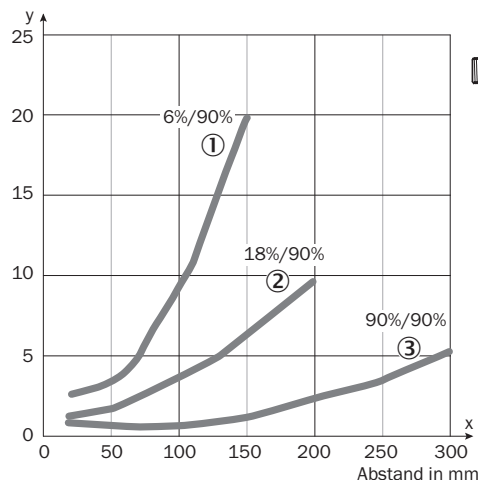

Beispiel:  
Schaltabstand auf Schwarz, 6%,  
x = 100 mm, y = (10% von 100 mm) = 10 mm

- ① Schaltabstand auf Schwarz, 6 % Remission
- ② Schaltabstand auf Grau, 18 % Remission
- ③ Schaltabstand auf Weiß, 90 % Remission

Figura 43: Distância de comutação até 300 mm

Para verificar a função, consultar figura 44 e a tabela 3. Se a saída de comutação não se comportar de acordo com a tabela 3, verificar as condições de uso. Ver o item Diagnóstico de erros.

### 3 ajuste da distância de comutação

Sensor sem possibilidade de ajuste: sensor está ajustado e operacional.

A distância de comutação é ajustada com o potenciômetro (tipo: 270°). Giro para direita: aumento da distância de comutação; giro para esquerda: redução da distância de comutação. Recomendamos posicionar a distância de comutação no objeto, p. ex. ver tabela 19. Após o ajuste da distância de comutação, remover o objeto do caminho óptico; o fundo é suprimido e a saída de comutação se altera [ver tabela 18].

Tabela 19: Ajuste da distância de comutação

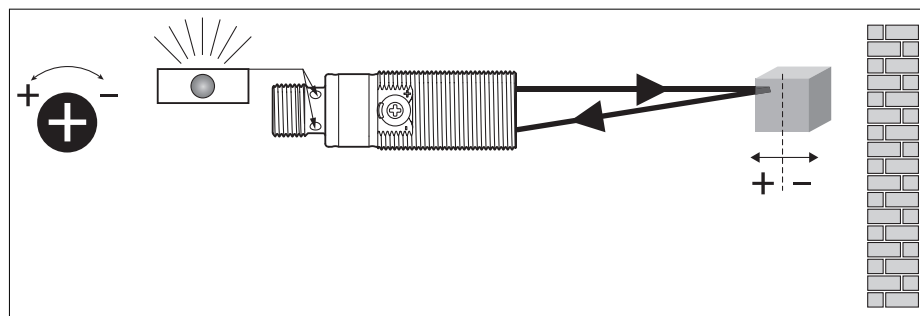

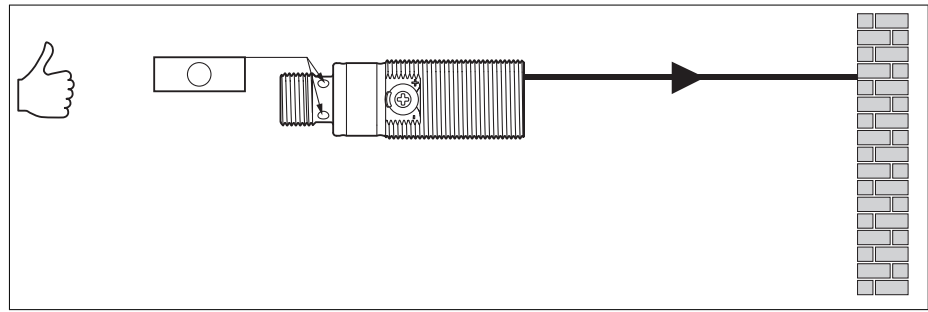

O sensor está ajustado e operacional.



Figura 44: Detecção

## 37 Eliminação de falhas

A tabela Eliminação de falhas mostra as medidas a serem executadas, quando o sensor não estiver funcionando.

### 37.1 Tabela de eliminação de falhas

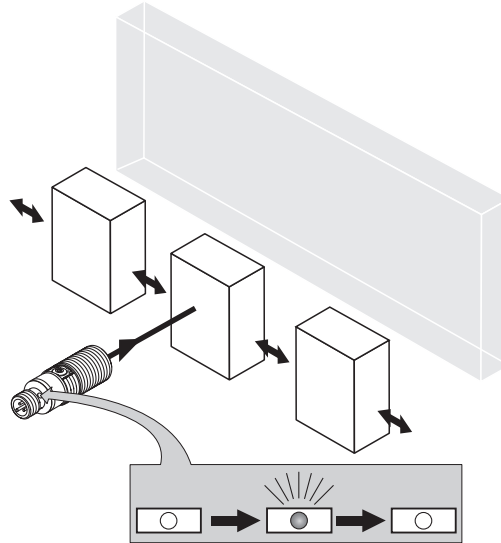
Tabela 20: Eliminação de falhas

Indicador LED / padrão de erro	Causa	Medida
LED verde apagado	Sem tensão ou tensão abaixo dos valores-limite	Verificar a alimentação de tensão, verificar toda a conexão elétrica (cabos e conectores)
LED verde apagado	Interrupções de tensão	Assegurar uma alimentação de tensão estável sem interrupções
LED verde apagado	Sensor está com defeito	Se a alimentação de tensão estiver em ordem, substituir o sensor
LED amarelo intermitente	Sensor ainda está operacional, mas as condições de operação não são ideais	Verificar as condições de operação: Alinhar o feixe de luz (ponto de luz) totalmente sobre o objeto / Limpeza das superfícies ópticas / Reajustar a sensibilidade (potenciômetro) / Verificar e, se neces-

Indicador LED / padrão de erro	Causa	Medida
		sário, adaptar a distância de comutação, <a href="#">ver figura 43, página 42</a>
LED amarelo aceso, nenhum objeto no caminho óptico	Distância entre sensor e fundo é pequena demais	Reduzir a distância de comutação, <a href="#">ver figura 43</a>
Objeto está no caminho óptico, LED amarelo apagado	Distância entre sensor e objeto é grande demais ou distância de comutação foi ajustada para um valor baixo demais	Aumentar a distância de comutação, observar a distância entre sensor e fundo, <a href="#">ver figura 43</a>

## 38 Desmontagem e descarte

O descarte do sensor deve ser efetuado de acordo com as normas aplicáveis específicas de cada país. No âmbito do descarte, deve-se procurar o aproveitamento dos materiais recicláveis contidos (principalmente dos metais nobres).

## 39 Manutenção

Os sensores SICK não requerem manutenção.

Recomendamos que se efetue em intervalos regulares

- uma limpeza das superfícies ópticas
- uma verificação das conexões roscadas e dos conectores

Não são permitidas modificações no aparelho.

Sujeito a alterações sem aviso prévio. As propriedades do produto e os dados técnicos especificados não constituem nenhum certificado de garantia.

## 40 Dados técnicos

	GRTB18(S)-xxx1xV	GRTB18(S)-xxx3xV	GRTB18(S)-xxx2xV
Distância de comutação	3 ... 300 mm	3 ... 100 mm	3 ... 200 mm
Distância de comutação máx.	3 ... 300 mm <sup>1</sup>	3 ... 100 mm <sup>1</sup>	3 ... 200 mm <sup>1</sup>
Opção de configuração	Potenciômetro	Nenhuma opção de configuração	Nenhuma opção de configuração
Diâmetro do ponto de luz/distância	7 mm / 100 mm	7 mm / 100 mm	7 mm / 100 mm
Tensão de alimentação U <sub>V</sub>	DC 10 ... 30 V <sup>2</sup>	DC 10 ... 30 V <sup>2</sup>	DC 10 ... 30 V <sup>2</sup>
Corrente de saída I <sub>max.</sub>	100 mA	100 mA	100 mA
Sequência máx. de comutação	1,000 Hz <sup>5</sup>	1,000 Hz <sup>5</sup>	1,000 Hz <sup>5</sup>
Tempo máx. de resposta	< 0.5 ms <sup>6</sup>	< 0.5 ms <sup>6</sup>	< 0.5 ms <sup>6</sup>
Tipo de proteção	IP67,IP68,IP69K <sup>11</sup>	IP67,IP68,IP69K <sup>11</sup>	IP67,IP68,IP69K <sup>11</sup>
Classe de proteção	III <sup>8</sup>	III <sup>8</sup>	III <sup>8</sup>
Circuitos de proteção	A,B,D <sup>10</sup>	A,B,D <sup>10</sup>	A,B,D <sup>10</sup>
Temperatura ambiente de funcionamento	-25 °C ... +55 °C	-25 °C ... +55 °C	-25 °C ... +55 °C

- 1 Tastgut mit 90 % Remission (bezogen auf Standard-Weiß DIN 5033)  
2 Grenzwerte; Betrieb im kurzschlussgeschützten Netz max. 8 A; Restwelligkeit max. 5 V<sub>ss</sub>  
3 Gebrauchskategorie: AC-15, DC-13 (EN 60947-1)  
4 Mit Hell- / Dunkelverhältnis 1:1  
5 Signallaufzeit bei ohmscher Last  
6 gültig für Q\ auf Pin2, wenn per Software konfiguriert  
7 Bemessungsspannung DC 50 V  
8 A = U<sub>V</sub>-Anschlüsse verpolsicher  
9 B = Ein- und Ausgänge verpolsicher  
10 D = Ausgänge überstrom- und kurzschlussfest  
11 IP68: conforme EN 60529 (10 m profundidade da água / 24 h).  
IP69K: conforme ISO 20653:2013-03.

# GRTB18(S)V

Sensore fotoelettrico cilindrico

**SICK**  
Sensor Intelligence.

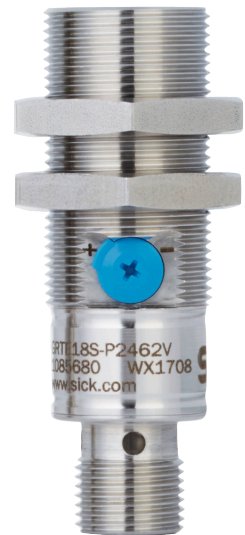
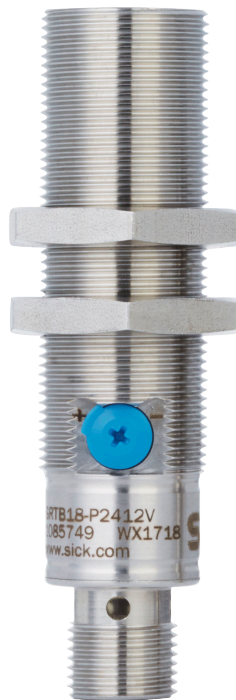

de  
en  
es  
fr  
it  
ja  
pt  
ru  
zh

### Descrizione prodotto

GR18 Inox  
GRTB18(S)V

### Produttore

SICK AG  
Erwin-Sick-Str. 1  
79183 Waldkirch  
Germania

### Luogo di produzione

SICK Malesia

### Note legali

Questo manuale è protetto dai diritti d'autore. I diritti che ne conseguono rimangono alla ditta SICK. Il manuale o parti di esso possono essere fotocopiati esclusivamente entro i limiti previsti dalle disposizioni di legge in materia di diritti d'autore. Non è consentito modificare, abbreviare o tradurre il presente manuale senza previa autorizzazione scritta della ditta SICK AG.

I marchi riportati nel presente manuale sono di proprietà del rispettivo proprietario.

© SICK AG. Tutti i diritti riservati.

### Documento originale

Questo documento è un originale della ditta SICK AG.



**Indice**

<b>41</b>	<b>avvertenze di sicurezza.....</b>	<b>49</b>
<b>42</b>	<b>Uso conforme alle disposizioni.....</b>	<b>49</b>
<b>43</b>	<b>Elementi di comando e di visualizzazione.....</b>	<b>49</b>
<b>44</b>	<b>Montaggio.....</b>	<b>50</b>
<b>45</b>	<b>Installazione elettronica.....</b>	<b>51</b>
<b>46</b>	<b>Messa in servizio.....</b>	<b>52</b>
<b>47</b>	<b>Eliminazione difetti.....</b>	<b>54</b>
	47.1 Tabella rimozione dei guasti.....	54
<b>48</b>	<b>Smontaggio e smaltimento.....</b>	<b>55</b>
<b>49</b>	<b>Manutenzione.....</b>	<b>55</b>
<b>50</b>	<b>Dati tecnici.....</b>	<b>56</b>



## 41 avvertenze di sicurezza

- Prima della messa in funzione leggere le istruzioni per l'uso.
-  Collegamento, montaggio e regolazione solo a cura di personale tecnico specializzato.
- Non è un componente di sicurezza ai sensi della direttiva macchine UE.
- Power supply: Class 2  
Enclosure type 1
- Alla messa in funzione proteggere l'apparecchio dall'umidità e dalla sporcizia.
- Le presenti istruzioni per l'uso contengono informazioni necessarie durante il ciclo di vita del sensore.

## 42 Uso conforme alle disposizioni

GRTB18(S)V è un sensore fotoelettrico energetico (di seguito detto sensore) utilizzato per il rilevamento ottico senza contatto di oggetti, animali e persone. Se viene utilizzato diversamente e in caso di modifiche del prodotto, decade qualsiasi diritto alla garanzia nei confronti di SICK.

## 43 Elementi di comando e di visualizzazione

Sensore fotoelettrico energetico con soppressione di sfondo.

Tabella 21: Disegni quotati



Figura 45: Forma costruttiva corta, cavo di collegamento



Figura 46: Forma costruttiva corta, connettore maschio M12

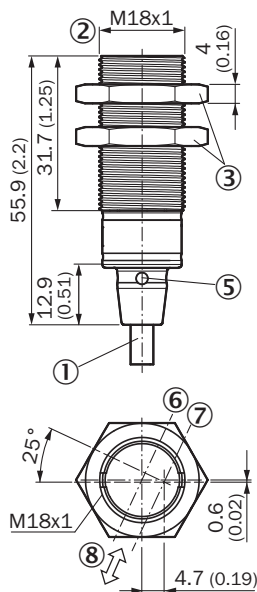

Figura 47: Forma costruttiva corta, potenziometro, cavo di collegamento

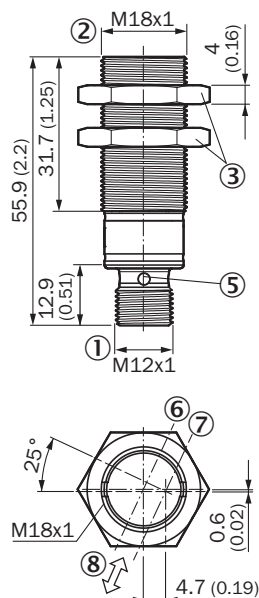

Figura 48: Forma costruttiva corta, potenziometro, connettore maschio M12

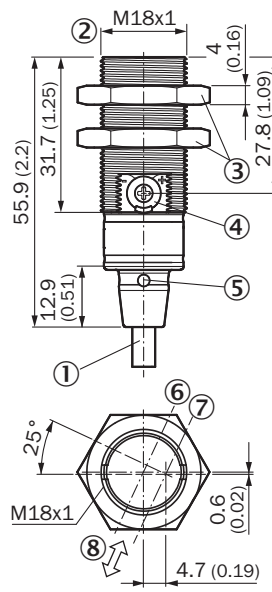

Figura 49: Forma costruttiva lunga, cavo di collegamento

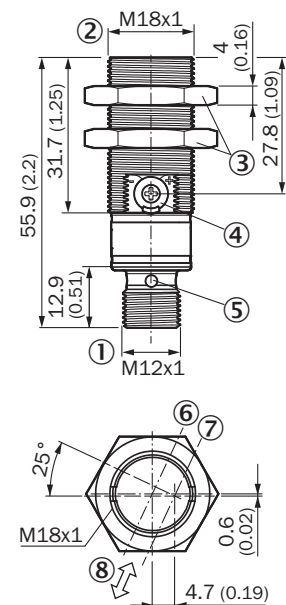

Figura 50: Forma costruttiva lunga, connettore maschio M12

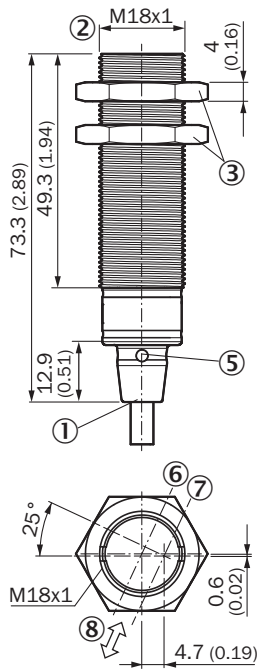

Figura 51: Forma costruttiva lunga, potenziometro, cavo di collegamento

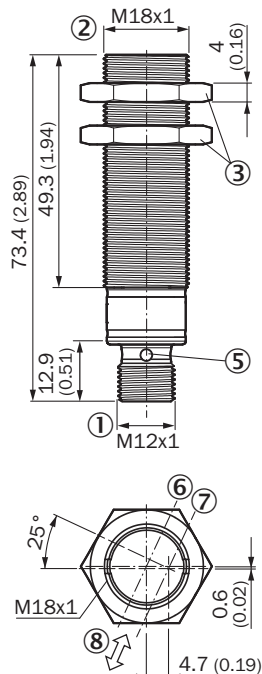

Figura 52: Forma costruttiva lunga, potenziometro, connettore maschio M12

- ① Collegamento
- ② Vite di fissaggio M18 x 1
- ③ Dado di fissaggio (2 x); WS24, acciaio inox
- ④ Potenziometro, 270°
- ⑤ Visualizzazione LED (4 x)
- ⑥ Asse ottico, ricevitore
- ⑦ Asse ottico, emettitore
- ⑧ Direzione preferenziale

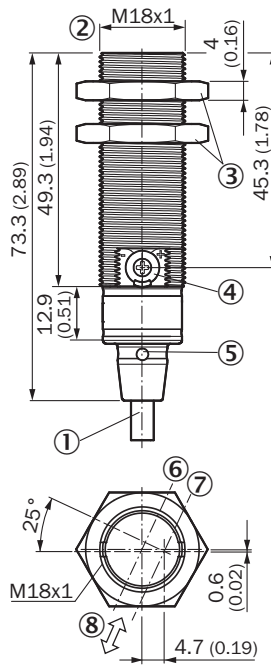

Figura 53: Comando: distanza di lavoro

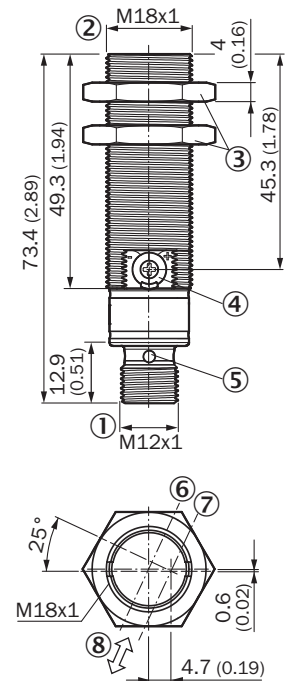
## 44 Montaggio

Montare il sensore su una staffa di fissaggio adatta (vedi il programma per accessori SICK).

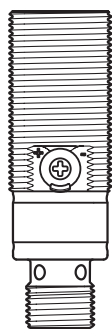
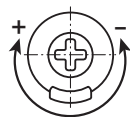
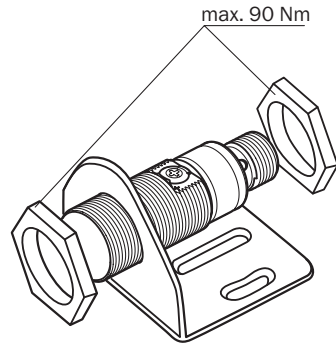

Rispettare la coppia di serraggio massima consentita del sensore di 90 Nm.

Rispettare la direzione preferenziale dell'oggetto in relazione al sensore, cfr. [tabella 21](#).

## 45 Installazione elettronica

Il collegamento dei sensori deve avvenire in assenza di tensione ( $U_V = 0\text{ V}$ ). In base al tipo di collegamento si devono rispettare le seguenti informazioni:

- Collegamento a spina: assegnazione pin
- Cavo: colore filo

Solamente in seguito alla conclusione di tutti i collegamenti elettrici, ripristinare o accendere l'alimentazione elettrica ( $U_V > 0\text{ V}$ ). Sul sensore si accende l'indicatore LED verde.

Spiegazioni dello schema di collegamento (Tabelle 2 e 3):

$Q / \bar{Q}$  = uscite di commutazione

n. c. = non collegato

**DC: 10... 30 V DC, v. „Dati tecnici“, pagina 56**

Tabella 22: DC

GRTB18(S)V	x11xxx	x13xxx	x24xxx	x23xxx
1	+ (L+)	+ (L+)	+ (L+)	+ (L+)
2	$\bar{Q}$	n. c.	$\bar{Q}$	n. c.
3	- (M)	- (M)	- (M)	- (M)
4	Q	Q	Q	Q
	<p>1 = brn 2 = wht 3 = blu 4 = blk 0,14 mm<sup>2</sup> AWG26</p>	<p>1 = brn - 3 = blu 4 = blk 0,14 mm<sup>2</sup> AWG26</p>		

Tabella 23: DC

PNP: Q/ ( $\leq 100$ mA)		
NPN: Q ( $\leq 100$ mA)		
PNP: $\bar{Q}$ ( $\leq 100$ mA)		
NPN: $\bar{Q}$ ( $\leq 100$ mA)		

## 46 Messa in servizio

### 1 Orientamento

Orientare il sensore sull'oggetto. Scegliere la posizione in modo tale che il raggio di luce rosso emesso colpisca il centro dell'oggetto. Fare attenzione che l'apertura ottica (frontalino) del sensore sia completamente libera [v. figura].



Figura: Orientamento

### 2 Distanza di lavoro

Controllare le condizioni d'impiego: predisporre la distanza di lavoro e la distanza dall'oggetto o dallo sfondo nonché il fattore di riflessione dell'oggetto in base al relativo diagramma [v. figura 54] (x = distanza di lavoro, y = area di transizione tra distanza di lavoro impostata e schermatura dello sfondo in % della distanza di lavoro (remissione oggetto/remissione sfondo)). Coefficiente di riflessione: 6% = nero ①, 18% = grigio ②, 90% = bianco ③ (riferito al bianco standard secondo DIN 5033). Si consiglia di effettuare l'impostazione con un oggetto con basso coefficiente di riflessione.

La distanza minima (= y) per la soppressione dello sfondo può venire rilevata dal diagramma [v. figura 54 ①] come segue:

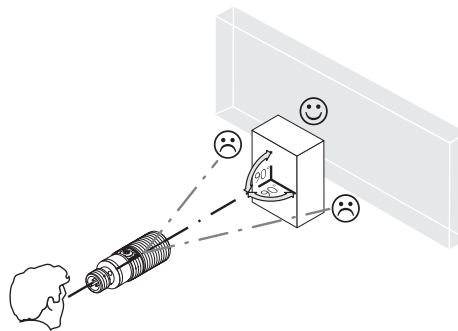
Esempio: x = 150 mm, y = 20 => 20% di 150 mm = 30 mm. Questo significa che lo sfondo viene soppresso a partire da una distanza > 180 mm dal sensore.

Mindestabstand in mm (y) zwischen eingestelltem Schaltabstand und Hintergrund (weiß, 90%) in %-Abhängigkeit des Schaltabstandes

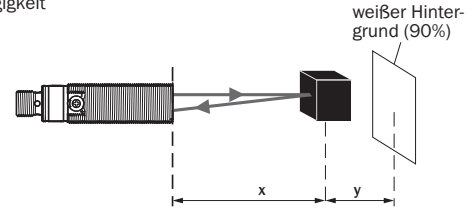
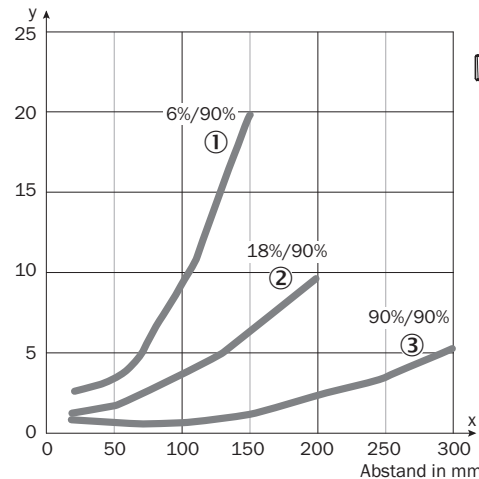

Beispiel:  
Schaltabstand auf Schwarz, 6%,  
x = 100 mm, y = (10% von 100 mm) = 10 mm

- ① Schaltabstand auf Schwarz, 6 % Remission
- ② Schaltabstand auf Grau, 18 % Remission
- ③ Schaltabstand auf Weiß, 90 % Remission

Figura 54: Distanza di lavoro fino a 300 mm

Per verificare il funzionamento, osservare figura 55 e tabella 3. Se l'uscita di commutazione non si comporta conformemente alla tabella 3, verificare le condizioni d'impiego. Vedi paragrafo Diagnostica delle anomalie.

### 3 Regolazione distanza di lavoro

Sensore senza possibilità di impostazione: il sensore è impostato e pronto per il funzionamento.

Con il potenziometro (tipo: 270°) viene regolata la distanza di lavoro. Rotazione verso destra: innalzamento della distanza di lavoro, rotazione verso sinistra: riduzione della distanza di lavoro. Si consiglia di inserire nell'oggetto la distanza di lavoro, ad es. v. tabella 24. In seguito all'impostazione della distanza di lavoro, allontanare l'oggetto dalla traiettoria del raggio, lo sfondo viene quindi soppresso e l'uscita di commutazione cambia [v. tabella 23 e ].

Tabella 24: Regolazione distanza di lavoro

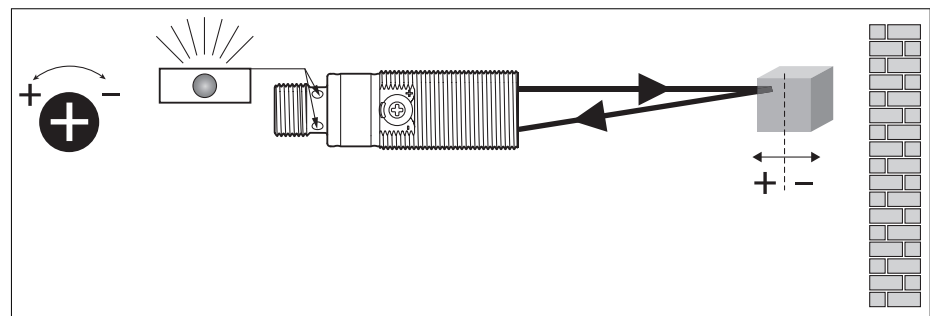

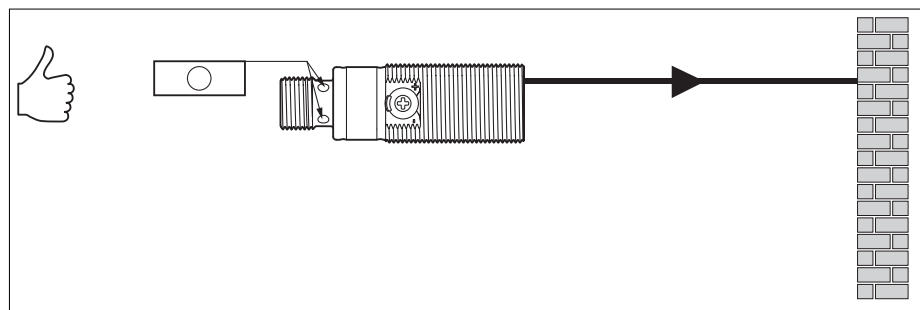

Il sensore è impostato e pronto per il funzionamento.



Figura 55: Rilevamento

## 47 Eliminazione difetti

La tabella di rimozione dei disturbi mostra quali provvedimenti si devono adottare quando il sensore non funziona più.

### 47.1 Tabella rimozione dei guasti

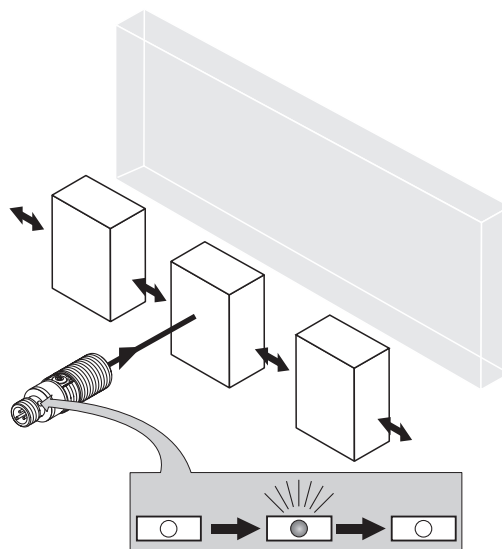
Tabella 25: Eliminazione dei guasti

Indicatore LED / figura di errore	Causa	Provvedimento
Il LED verde non si accende	nessuna tensione o tensione al di sotto del valore soglia	Verificare la tensione di alimentazione e/o il collegamento elettrico
Il LED verde non si accende	Interruzioni di tensione	Assicurarsi che ci sia un'alimentazione di tensione stabile
Il LED verde non si accende	Il sensore è guasto	Se l'alimentazione di tensione è regolare, allora chiedere una sostituzione del sensore
Il LED giallo lampeggia	Il sensore è ancora pronto per il funzionamento, ma le condizioni di esercizio non sono ottimali	Controllare le condizioni di esercizio: Dirigere il raggio di luce (il punto luminoso) completamente sull'oggetto / Pulizia delle superfici ottiche / Sensibilità (potenziometro) /

Indicatore LED / figura di errore	Causa	Provvedimento
		Controllare la distanza di lavoro e, se necessario, adattarla, v. figura 54, pagina 53
il LED giallo si accende, nessun oggetto nella traiettoria del raggio	La distanza tra sensore e sfondo è inferiore alle capacità di funzionamento	Diminuire la distanza di lavoro, v. figura 54
L'oggetto è nella traiettoria del raggio, il LED giallo non si accende	La distanza tra sensore e oggetto è troppo grande o la distanza di commutazione ha un'impostazione troppo bassa	Aumentare la distanza di lavoro, rispettare la distanza tra sensore e sfondo, v. figura 54

## 48 Smontaggio e smaltimento

Lo smaltimento del sensore deve avvenire conformemente alle direttive previste specificatamente dal paese. Per i materiali riciclabili in esso contenuti (in particolare metalli nobili) si auspica un riciclaggio nell'ambito dello smaltimento.

## 49 Manutenzione

I sensori SICK sono esenti da manutenzione.

A intervalli regolari si consiglia di

- pulire le superfici limite ottiche
- Verificare i collegamenti a vite e gli innesti a spina

Non è consentito effettuare modifiche agli apparecchi.

Contenuti soggetti a modifiche senza preavviso. Le proprietà del prodotto e le schede tecniche indicate non costituiscono una dichiarazione di garanzia.

## 50 Dati tecnici

	GRTB18(S)-xxx1xV	GRTB18(S)-xxx3xV	GRTB18(S)-xxx2xV
Distanza di commutazione	3 ... 300 mm	3 ... 100 mm	3 ... 200 mm
Distanza max. di commutazione	3 ... 300 mm <sup>1</sup>	3 ... 100 mm <sup>1</sup>	3 ... 200 mm <sup>1</sup>
Possibilità di regolazione	Potenziometro	Nessuna possibilità di regolazione	Nessuna possibilità di regolazione
Diametro punto luminoso/distanza	7 mm / 100 mm	7 mm / 100 mm	7 mm / 100 mm
Tensione di alimentazione U <sub>V</sub>	DC 10 ... 30 V <sup>2</sup>	DC 10 ... 30 V <sup>2</sup>	DC 10 ... 30 V <sup>2</sup>
Corrente di uscita I <sub>max.</sub>	100 mA	100 mA	100 mA
Sequenza di commutazione max.	1,000 Hz <sup>5</sup>	1,000 Hz <sup>5</sup>	1,000 Hz <sup>5</sup>
Tempo di reazione max.	< 0.5 ms <sup>6</sup>	< 0.5 ms <sup>6</sup>	< 0.5 ms <sup>6</sup>
Tipo di protezione	IP67,IP68,IP69K <sup>11</sup>	IP67,IP68,IP69K <sup>11</sup>	IP67,IP68,IP69K <sup>11</sup>
Classe di protezione	III <sup>8</sup>	III <sup>8</sup>	III <sup>8</sup>
Commutazioni di protezione	A,B,D <sup>10</sup>	A,B,D <sup>10</sup>	A,B,D <sup>10</sup>
Temperatura ambientale di funzionamento	-25 °C ... +55 °C	-25 °C ... +55 °C	-25 °C ... +55 °C

- 1 Tastgut mit 90 % Remission (bezogen auf Standard-Weiß DIN 5033)  
2 Grenzwerte; Betrieb im kurzschlussgeschützten Netz max. 8 A; Restwelligkeit max. 5 V<sub>ss</sub>  
4 Gebrauchskategorie: AC-15, DC-13 (EN 60947-1)  
5 Mit Hell- / Dunkelverhältnis 1:1  
6 Signallaufzeit bei ohmscher Last  
7 gültig für Q\ auf Pin2, wenn per Software konfiguriert  
8 Bemessungsspannung DC 50 V  
10 A = U<sub>V</sub>-Anschlüsse verpolsicher  
B = Ein- und Ausgänge verpolsicher  
D = Ausgänge überstrom- und kurzschlussfest  
11 IP68: secondo EN 60529 (10 m profondità dell'acqua / 24 h).  
IP69K: secondo ISO 20653:2013-03.



# GRTB18(S)V

Sensores fotoeléctricos cilíndricos

**SICK**  
Sensor Intelligence.

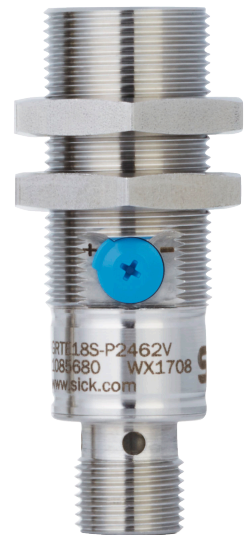
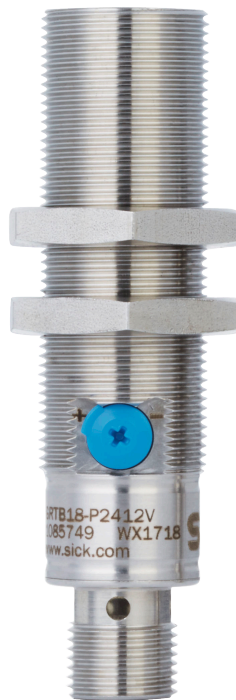

de  
en  
es  
fr  
it  
ja  
pt  
ru  
zh

### Producto descrito

GR18 Inox  
GRTB18(S)V

### Fabricante

SICK AG  
Erwin-Sick-Str. 1  
79183 Waldkirch  
Alemania

### Centro de producción

SICK, Malasia

### Información legal

Este documento está protegido por la legislación sobre la propiedad intelectual. Los derechos derivados de ello son propiedad de SICK AG. Únicamente se permite la reproducción total o parcial de este documento dentro de los límites establecidos por las disposiciones legales sobre propiedad intelectual. Está prohibida la modificación, abreviación o traducción del documento sin la autorización expresa y por escrito de SICK AG.

Las marcas mencionadas en este documento pertenecen a sus respectivos propietarios.

© SICK AG. Reservados todos los derechos.

### Documento original

Este es un documento original de SICK AG.



## Índice

<b>51</b>	<b>Indicaciones de seguridad.....</b>	<b>60</b>
<b>52</b>	<b>Uso conforme a lo previsto.....</b>	<b>60</b>
<b>53</b>	<b>Elementos de mando y visualización.....</b>	<b>60</b>
<b>54</b>	<b>Montaje.....</b>	<b>61</b>
<b>55</b>	<b>Instalación electrónica.....</b>	<b>62</b>
<b>56</b>	<b>Puesta en servicio.....</b>	<b>63</b>
<b>57</b>	<b>Resolución de problemas.....</b>	<b>65</b>
	57.1 Tabla de solución de problemas.....	65
<b>58</b>	<b>Desmontaje y eliminación.....</b>	<b>66</b>
<b>59</b>	<b>Mantenimiento.....</b>	<b>66</b>
<b>60</b>	<b>Datos técnicos.....</b>	<b>67</b>

## 51 Indicaciones de seguridad

- Lea las instrucciones de uso antes de efectuar la puesta en servicio.
-  La conexión, el montaje y el ajuste deben efectuarlos exclusivamente técnicos especialistas.
- No se trata de un componente de seguridad según la Directiva de máquinas de la UE.
- Power supply: Class 2  
Enclosure type 1
- Proteja el dispositivo contra la humedad y la suciedad durante la puesta en servicio.
- Las presentes instrucciones de uso contienen información que puede serle necesaria durante todo el ciclo de vida del sensor.

## 52 Uso conforme a lo previsto

La GRTB18(S)V es una fotocélula optoelectrónica de detección sobre objeto (en lo sucesivo llamada sensor) empleada para la detección óptica y sin contacto de objetos, animales y personas. Cualquier uso diferente al previsto o modificación en el producto invalidará la garantía por parte de SICK AG.

## 53 Elementos de mando y visualización

Fotocélula de detección sobre objeto con supresión de fondo.

Tabla 26: Dibujos acotados



Figura 56: Diseño corto, cable de conexión



Figura 57: Diseño corto, conector macho M12

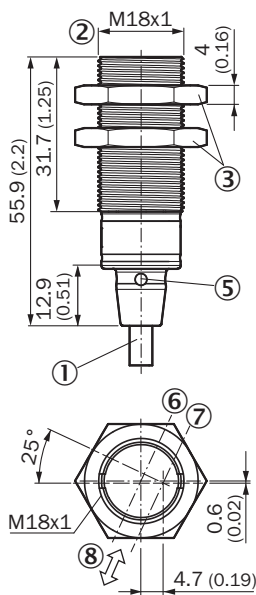

Figura 58: Diseño corto, potenciómetro, cable de conexión

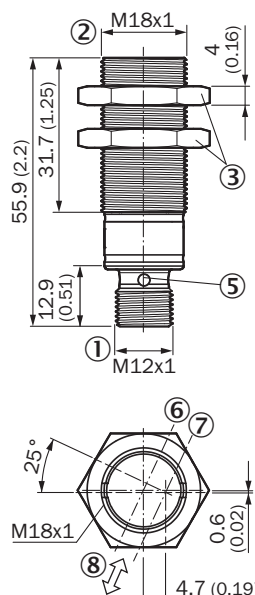

Figura 59: Diseño corto, potenciómetro, conector macho M12

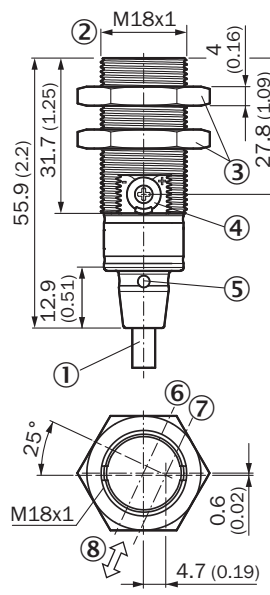

Figura 60: Diseño largo, cable de conexión

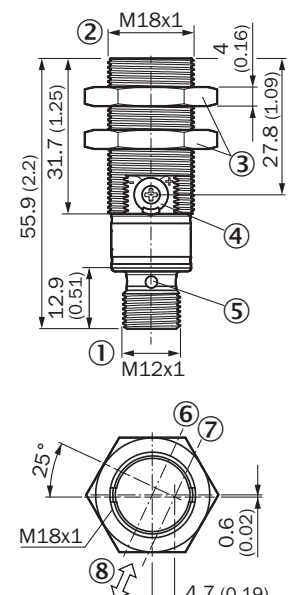

Figura 61: Diseño largo, conector macho M12

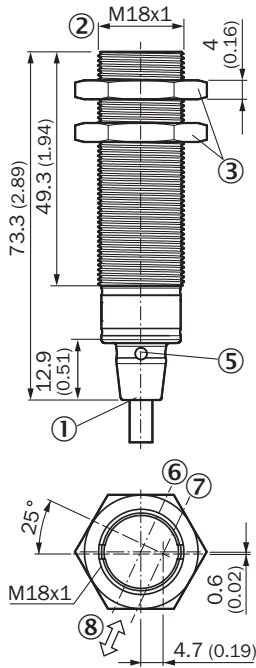

Figura 62: Diseño largo, potenciómetro, cable de conexión

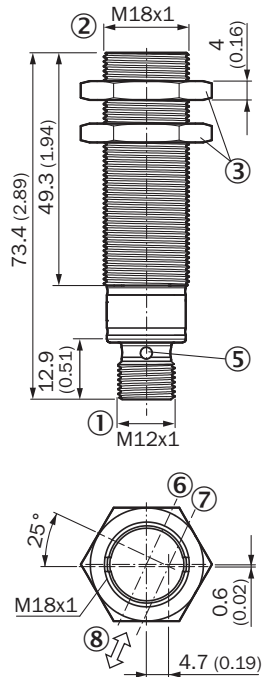

Figura 63: Diseño largo, potenciómetro, conector macho M12

- ① Conexión
- ② Rosca de fijación M18 x 1
- ③ Tuerca de fijación (2 x); WS24, acero inoxidable
- ④ Potenciómetro, 270°
- ⑤ Pantalla LED (4 x)
- ⑥ Eje óptico del receptor
- ⑦ Eje óptico del emisor
- ⑧ sentido preferente

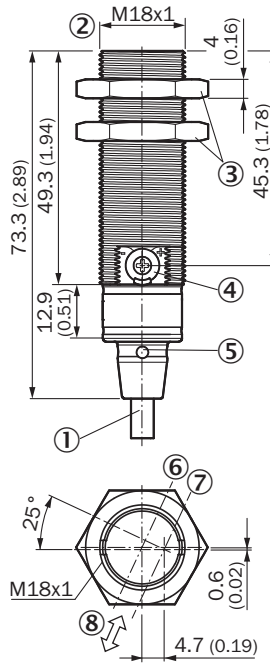

Figura 64: Elemento de control: Distancia de conmutación

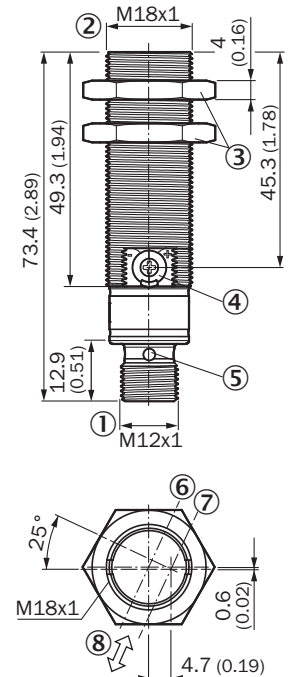
## 54 Montaje

Montar el sensor en una escuadra de fijación adecuada (véase el programa de accesorios SICK).

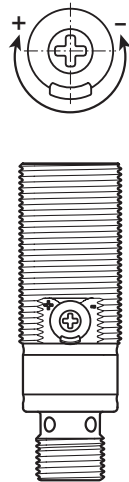
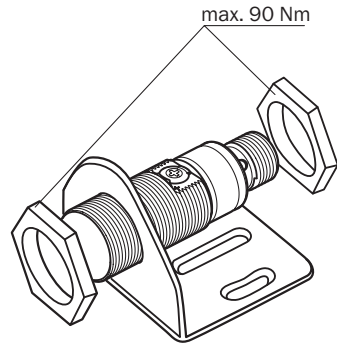

Respetar el par de apriete máximo admisible del sensor de 90 Nm.

Respetar la orientación preferente del objeto con respecto al sensor, véase [tabla 26](#).

## 55 Instalación electrónica

Los sensores deben conectarse sin tensión ( $V_S = 0\text{ V}$ ). Debe tenerse en cuenta la siguiente información en función de cada tipo de conexión:

- Conexión de enchufes: asignación de terminales
- Cable: color del hilo

No aplicar o conectar la fuente de alimentación ( $V_S > 0\text{ V}$ ) hasta que no se hayan finalizado todas las conexiones eléctricas. En el sensor se ilumina el LED indicador verde.

Explicaciones relativas al esquema de conexión (tablas 2 y 3):

Q /  $\bar{Q}$  = salidas conmutadas

n. c. = no conectado

**CC: 10 ... 30 V CC, véase „Datos técnicos“, página 67**

Tabla 27: CC

GRTB18(S)V	x11xxx	x13xxx	x24xxx	x23xxx
1	+ (L+)	+ (L+)	+ (L+)	+ (L+)
2	$\bar{Q}$	n. c.	$\bar{Q}$	n. c.
3	- (M)	- (M)	- (M)	- (M)
4	Q	Q	Q	Q
	 1 = brn (marrón) 2 = wht (blanco) 3 = blu (azul) 4 = blk (negro) 0,14 mm <sup>2</sup> AWG26	 1 = brn (marrón) - 3 = blu (azul) 4 = blk (negro) 0,14 mm <sup>2</sup> AWG26		

Tabla 28: CC

		
PNP: Q ( $\leq 100$ mA)		
NPN: Q ( $\leq 100$ mA)		
PNP: $\bar{Q}$ ( $\leq 100$ mA)		
NPN: $\bar{Q}$ ( $\leq 100$ mA)		

## 56 Puesta en servicio

### 1 Alineación

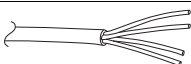
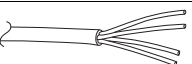
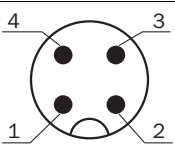
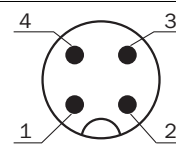
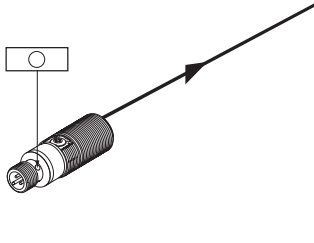
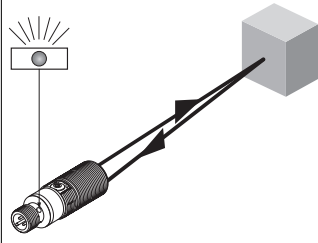
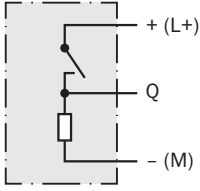
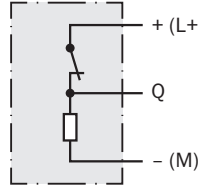
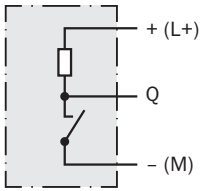
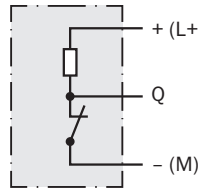
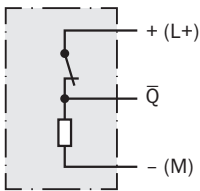
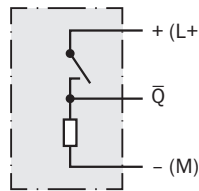
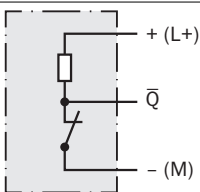
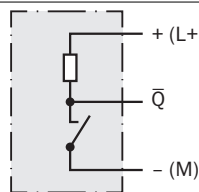
Orientar el sensor hacia el objeto. Debe seleccionarse una posición que permita que el haz de luz roja del emisor incida en el centro del objeto. Hay que procurar que la apertura óptica (pantalla frontal) del sensor esté completamente libre [véase figura].



Figura: Alineación

### 2 Distancia de conmutación

Comprobar las condiciones de aplicación: comparar la distancia de conmutación y la distancia respecto al objeto o al fondo, así como la capacidad de reflectancia del objeto, con el diagrama correspondiente [véase figura 65] (x = distancia de conmutación, y = zona de transición entre la distancia de conmutación ajustada y la supresión del fondo en % de la distancia de conmutación (reflectancia del objeto / reflectancia del fondo)). Reflectancia: 6% = negro ①, 18% = gris ②, 90% = blanco ③ (referido al blanco estándar según DIN 5033). Recomendamos realizar los ajustes con un objeto de reflectancia baja. La distancia mínima (= y) para suprimir el fondo puede calcularse a partir del diagrama [ véase figura 65 ①] del modo siguiente:  
Ejemplo: x = 150 mm, y = 20 => 20% de 150 mm = 30 mm. Es decir, el fondo se suprimirá a partir de una distancia de > 180 mm del sensor.

Mindestabstand in mm (y) zwischen eingestelltem Schaltabstand und Hintergrund (weiß, 90%) in %-Abhängigkeit des Schaltabstandes

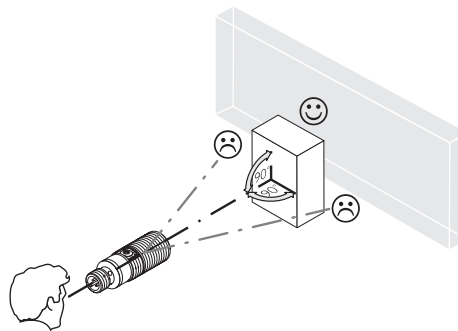
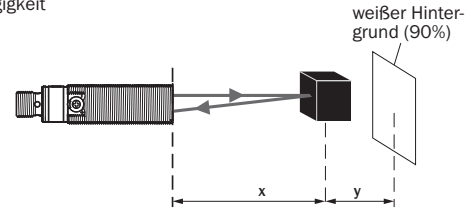
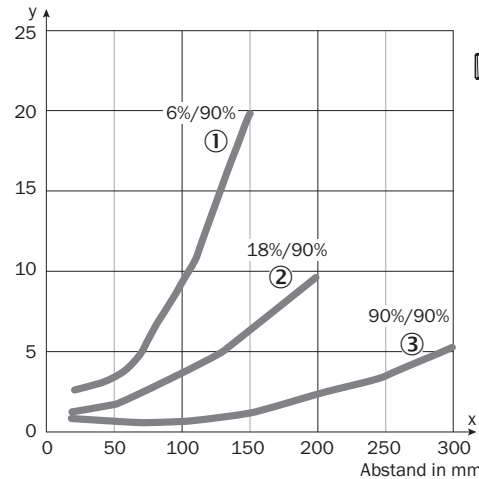

Beispiel:  
Schaltabstand auf Schwarz, 6%,  
x = 100 mm, y = (10% von 100 mm) = 10 mm

- ① Schaltabstand auf Schwarz, 6 % Remission
- ② Schaltabstand auf Grau, 18 % Remission
- ③ Schaltabstand auf Weiß, 90 % Remission

Figura 65: Distancia de conmutación de hasta 300 mm

Para verificar el funcionamiento, véanse figura 66 y la tabla 3. Si la salida conmutada no se comporta según la tabla 3, comprobar las condiciones de aplicación. Véase la sección “Diagnóstico de fallos”.

### 3 Ajuste de la distancia de conmutación

Sensor sin posibilidad de ajuste: el sensor está ajustado y listo para su uso.

Con el potenciómetro (tipo: 270°) se ajusta la distancia de conmutación. Giro hacia la derecha: aumenta la distancia de conmutación; giro hacia la izquierda: se reduce la distancia de conmutación. Recomendamos poner la distancia de conmutación en el objeto, p. ej. véase tabla 29. Una vez ajustada la distancia de conmutación, retirar el objeto de la trayectoria del haz, con lo cual el fondo se suprimirá y la salida conmutada cambiará [véase tabla 28].

Tabla 29: Ajuste de la distancia de conmutación

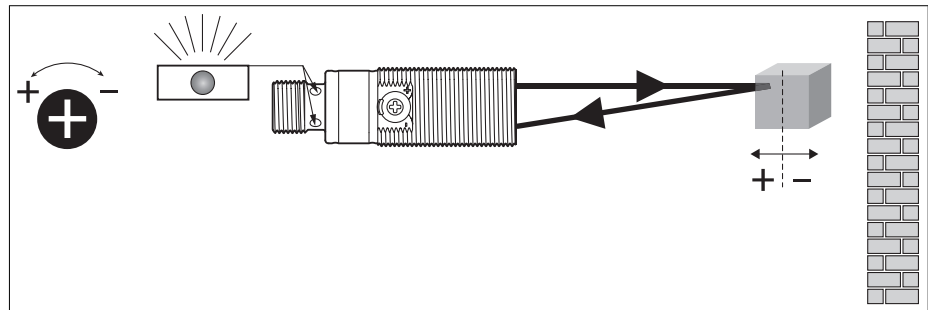



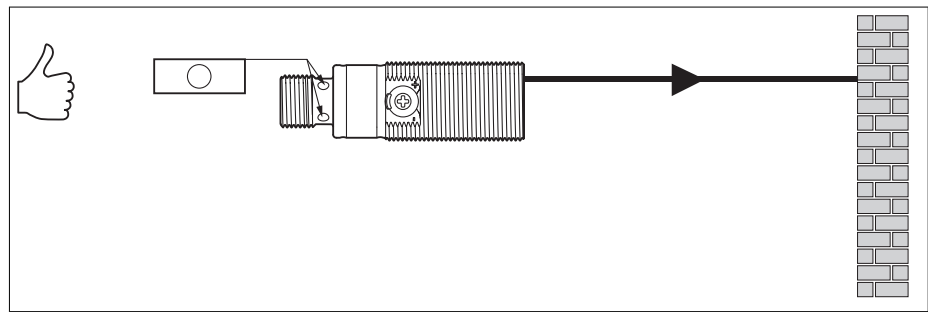

El sensor está ajustado y listo para su uso.



Figura 66: Detección

## 57 Resolución de problemas

La tabla “Resolución de problemas” muestra las medidas que hay que tomar cuando ya no está indicado el funcionamiento del sensor.

### 57.1 Tabla de solución de problemas

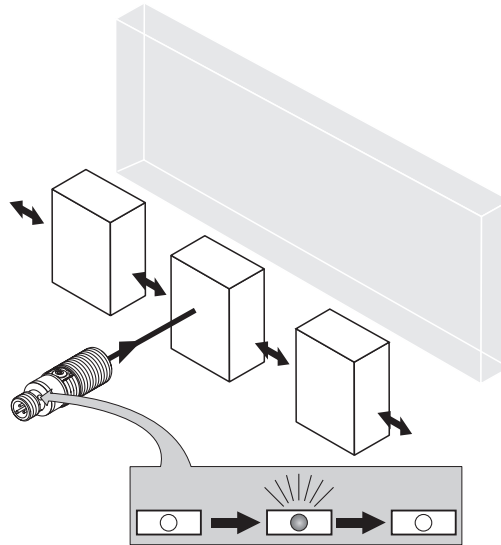
Tabla 30: Resolución de problemas

LED indicador / imagen de error	Causa	Acción
El LED verde no se ilumina	Sin tensión o tensión por debajo de los valores límite	Comprobar la fuente de alimentación, comprobar toda la conexión eléctrica (cables y conectores)
El LED verde no se ilumina	Interrupciones de tensión	Asegurar una fuente de alimentación estable sin interrupciones de tensión
El LED verde no se ilumina	El sensor está defectuoso	Si la fuente de alimentación no tiene problemas, cambiar el sensor
El LED amarillo parpadea	El sensor aún está operativo, pero las condiciones de servicio no son óptimas	Comprobar las condiciones de servicio: Alinear el haz de luz (spot) completamente con el objeto / Limpieza de las superficies ópticas / Reajus-

LED indicador / imagen de error	Causa	Acción
		tar la sensibilidad (potenciómetro) / Comprobar la distancia de conmutación y, si es necesario, adaptarla, véase figura 65, página 64
El LED amarillo se ilumina, no hay ningún objeto en la trayectoria del haz	La distancia entre el sensor y el fondo es insuficiente	Reducir la distancia de conmutación, véase figura 65
El objeto se encuentra en la trayectoria del haz, el LED amarillo no se ilumina	La distancia entre el sensor y el objeto es excesiva o la distancia de conmutación ajustada es insuficiente	Aumentar la distancia de conmutación teniendo en cuenta la distancia entre el sensor y el fondo, véase figura 65

## 58 Desmontaje y eliminación

El sensor tiene que eliminarse siguiendo la normativa aplicable específica de cada país. Los materiales valiosos que contenga (especialmente metales nobles) deben ser eliminados considerando la opción del reciclaje.

## 59 Mantenimiento

Los sensores SICK no precisan mantenimiento.

A intervalos regulares, recomendamos:

- Limpiar las superficies ópticas externas
- Comprobar las uniones roscadas y las conexiones.

No se permite realizar modificaciones en los aparatos.

Sujeto a cambio sin previo aviso. Las propiedades y los datos técnicos del producto no suponen ninguna declaración de garantía.

## 60 Datos técnicos

	GRTB18(S)-xxx1xV	GRTB18(S)-xxx3xV	GRTB18(S)-xxx2xV
Distancia de conmutación	3 ... 300 mm	3 ... 100 mm	3 ... 200 mm
Distancia de conmutación máx.	3 ... 300 mm <sup>1</sup>	3 ... 100 mm <sup>1</sup>	3 ... 200 mm <sup>1</sup>
Posibilidad de ajuste	Potenciómetro	sin posibilidad de ajuste	sin posibilidad de ajuste
Diámetro del punto luminoso/distancia	7 mm / 100 mm	7 mm / 100 mm	7 mm / 100 mm
Tensión de alimentación U <sub>V</sub>	DC 10 ... 30 V <sup>2</sup>	DC 10 ... 30 V <sup>2</sup>	DC 10 ... 30 V <sup>2</sup>
Intensidad de salida I <sub>max.</sub>	100 mA	100 mA	100 mA
Secuencia de conmutación máx.	1,000 Hz <sup>5</sup>	1,000 Hz <sup>5</sup>	1,000 Hz <sup>5</sup>
Tiempo de respuesta máx.	< 0.5 ms <sup>6</sup>	< 0.5 ms <sup>6</sup>	< 0.5 ms <sup>6</sup>
Tipo de protección	IP67,IP68,IP69K <sup>11</sup>	IP67,IP68,IP69K <sup>11</sup>	IP67,IP68,IP69K <sup>11</sup>
Clase de protección	III <sup>8</sup>	III <sup>8</sup>	III <sup>8</sup>
Circuitos de protección	A,B,D <sup>10</sup>	A,B,D <sup>10</sup>	A,B,D <sup>10</sup>
Temperatura ambiente de servicio	-25 °C ... +55 °C	-25 °C ... +55 °C	-25 °C ... +55 °C

- 1 Tastgut mit 90 % Remission (bezogen auf Standard-Weiß DIN 5033)  
2 Grenzwerte; Betrieb im kurzschlussgeschützten Netz max. 8 A; Restwelligkeit max. 5 V<sub>ss</sub>  
4 Gebrauchskategorie: AC-15, DC-13 (EN 60947-1)  
5 Mit Hell- / Dunkelverhältnis 1:1  
6 Signallaufzeit bei ohmscher Last  
7 gültig für Q\ auf Pin2, wenn per Software konfiguriert  
8 Bemessungsspannung DC 50 V  
10 A = U<sub>V</sub>-Anschlüsse verpolsicher  
B = Ein- und Ausgänge verpolsicher  
D = Ausgänge überstrom- und kurzschlussfest  
11 IP68: conforme a EN 60529 (10 m de profundidad en el agua / 24 h).  
IP69K: conforme a ISO 20653:2013-03.

# GRTB18(S)V

圆柱形光电传感器

**SICK**  
Sensor Intelligence.



de  
en  
es  
fr  
it  
ja  
pt  
ru  
zh

## 所说明的产品

GR18 Inox  
GRTB18(S)V

## 制造商

SICK AG  
Erwin-Sick-Str. 1  
79183 Waldkirch, Germany  
德国

## 生产基地

SICK, 马来西亚

## 法律信息

本文档受版权保护。其中涉及到的一切权利归西克公司所有。只允许在版权法的范围内复制本文档的全部或部分內容。未经西克公司的明确书面许可，不允许对文档进行修改、删减或翻译。

本文档所提及的商标为其各自所有者的资产。

© 西克公司版权所有。版权所有

## 原始文档

本文档为西克股份公司的原始文档。



## 内容

61	安全须知.....	71
62	规定用途.....	71
63	操作及显示元件.....	71
64	安装.....	72
65	电子安装.....	73
66	调试.....	74
67	故障排除.....	76
	67.1 故障排除表格.....	76
68	拆卸和废弃处理.....	77
69	保养.....	77
70	技术参数.....	78

## 61 安全须知

- 调试前请阅读操作指南。
-  仅允许由专业人员进行接线、安装和设置。
- 非欧盟机械指令中定义的安全部件。
- Power supply: Class 2  
Enclosure type 1
- 调试设备时应防潮防污染。
- 本操作指南中包含了传感器生命周期中必需的各项信息。

## 62 规定用途

GRTB18(S)V 是一种漫反射式光电传感器（下文简称为“传感器”），用于物体、动物和人体的非接触式光学检测。如滥用本产品或擅自对其改装，则 SICK 公司的所有质保承诺均将失效。

## 63 操作及显示元件

带背景抑制功能的漫反射式光电传感器

表格 31: 尺寸图



插图 67: 短构型, 连接电缆

插图 68: 短构型, M12 插头

插图 69: 短构型, 电位计, 连接电缆

插图 70: 短构型, 电位计, M12 插头

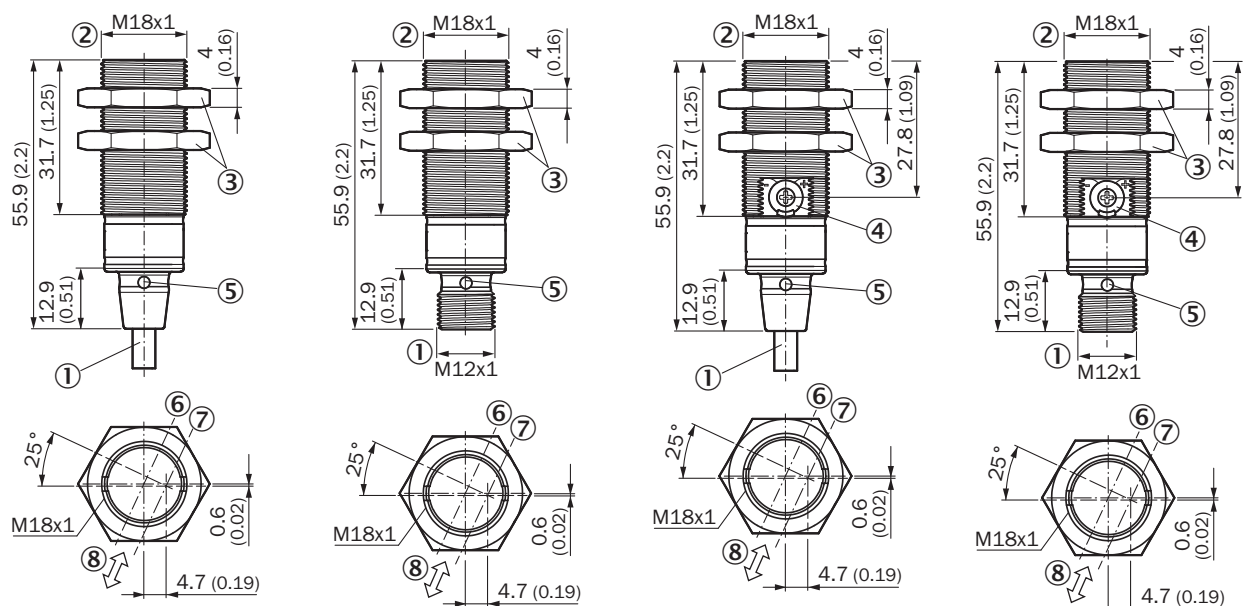

插图 71: 长构型, 连接电缆



插图 72: 长构型, M12 插头

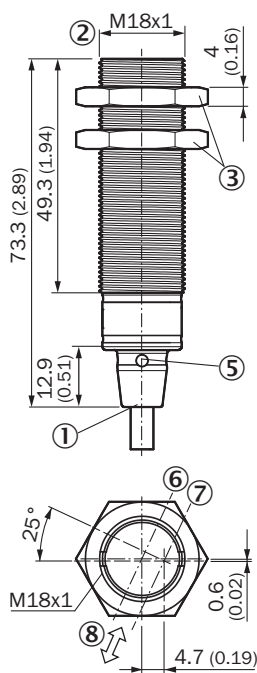

插图 73: 长构型, 电位计, 连接电缆

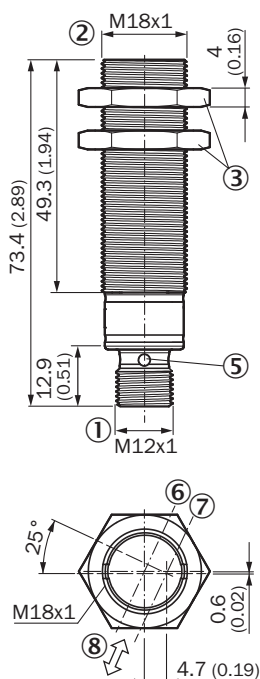

插图 74: 长构型, 电位计, M12 插头

- ① 接口
- ② 安装螺纹 M18 x 1
- ③ 固定螺母 (2 x); WS24, 不锈钢
- ④ 电位计, 270°
- ⑤ LED 指示灯 (4 x)
- ⑥ 光轴, 接收器
- ⑦ 光轴, 发射器
- ⑧ 优选方向

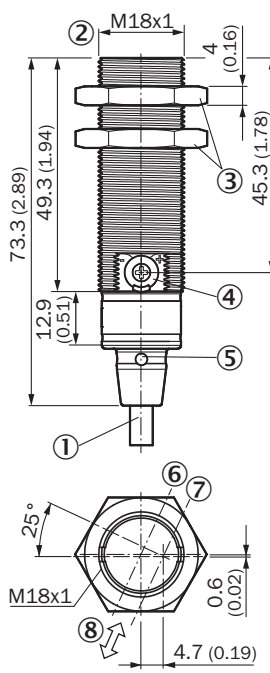

插图 75: 操作元件: 触发感应距离

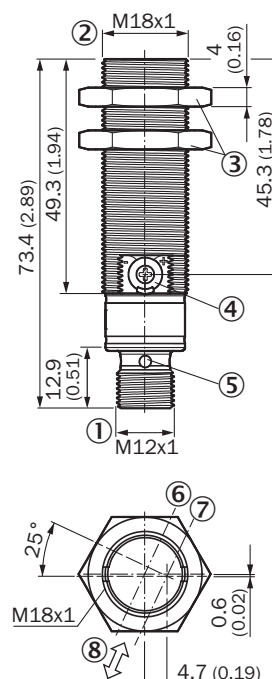
## 64 安装

将传感器安装在合适的安装支架上 (参见 SICK 配件目录)。



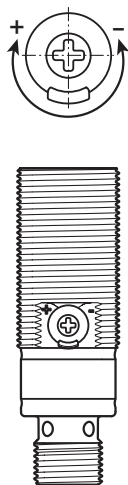
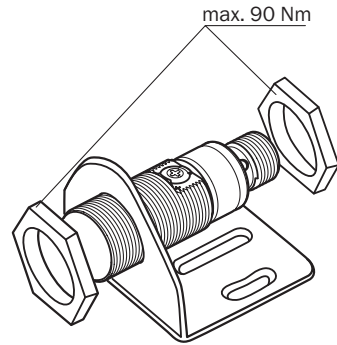

注意传感器的最大允许拧紧扭矩为 90 Nm。

以传感器为参照物，注意物体的优先方向，参照 [表格 31](#)。

## 65 电子安装

必须在无电压状态 ( $U_V = 0\text{ V}$ ) 连接传感器。依据不同连接类型，注意下列信息：

- 插头连接：引线分配
- 电缆：芯线颜色

完成所有电气连接后，才可施加或接通电压供给 ( $U_V > 0\text{ V}$ )。传感器上的绿色 LED 指示灯亮起。

接线图 (表格 2 和 3) 说明：

Q /  $\bar{Q}$  = 开关量输出

n. c. = 未连接

**DC: 10... 30 V DC, 参见 „技术参数“, 第 78 页**

表格 32: DC

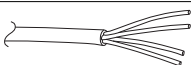
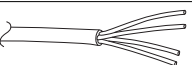
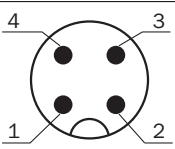
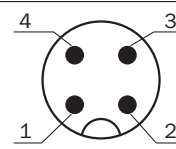
GRTB18(S)V	x11xxx	x13xxx	x24xxx	x23xxx
1	+ (L+)	+ (L+)	+ (L+)	+ (L+)
2	$\bar{Q}$	n. c.	$\bar{Q}$	n. c.
3	- (M)	- (M)	- (M)	- (M)
4	Q	Q	Q	Q
	 1 = brn (棕) 2 = wht (白) 3 = blu (蓝) 4 = blk (黑) 0.14 mm <sup>2</sup> AWG26	 1 = brn (棕) - 3 = blu (蓝) 4 = blk (黑) 0.14 mm <sup>2</sup> AWG26		

表格 33: DC

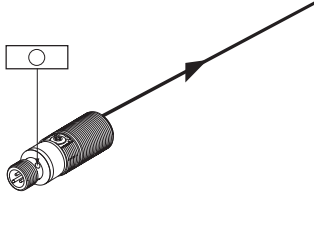
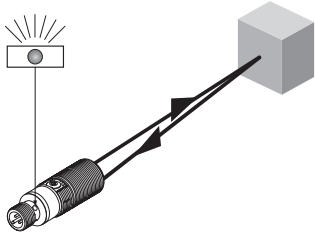
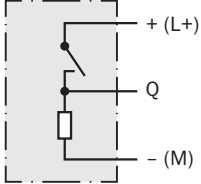
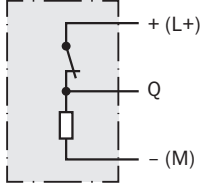
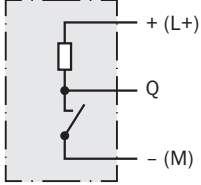
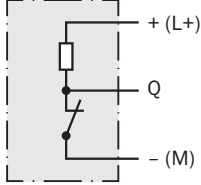
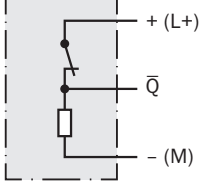
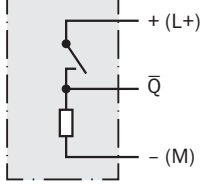
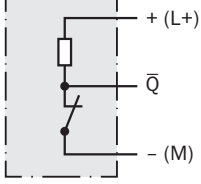
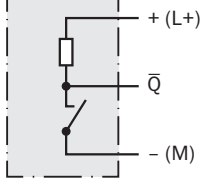
		
PNP: Q ( $\leq 100$ mA)		
NPN: Q ( $\leq 100$ mA)		
PNP: $\bar{Q}$ ( $\leq 100$ mA)		
NPN: $\bar{Q}$ ( $\leq 100$ mA)		

## 66 调试

### 1 校准

将传感器对准物体。选择定位，确保红色发射光束射中物体的中间。此时，应注意传感器的光学开口（透明保护盖）处应无任何遮挡 [参见插图]。



插图: 校准

### 2 触发感应距离

检查使用条件: 使用随附的图表 [参见插图 76] 调整触发感应距离和物体距离, 或背景及物体的反射能力 ( $x$  = 触发感应距离,  $y$  = 已设置的触发感应距离和触发感应距离背景抑制 (单位: %) 之间的过渡区 (物体反射比/背景反射比)。反射比: 6% = 黑色 ①, 18% = 灰色 ②, 90% = 白色 ③ (DIN 5033 规定的标准白)。我们建议使用反射比较低的物体进行设置。

背景抑制功能的最小距离 (=  $y$ ) 可根据图表 [参见插图 76 ①] 按如下方法确定:

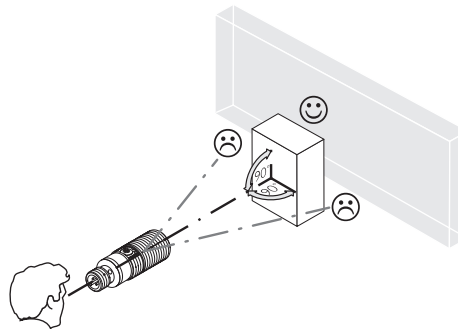
示例:  $x = 150 \text{ mm}$ ,  $y = 20 \Rightarrow 20\%$  的  $150 \text{ mm} = 30 \text{ mm}$ . 即, 自传感器距离  $> 180 \text{ mm}$  时, 才能抑制背景。

Mindestabstand in mm ( $y$ ) zwischen eingestelltem Schaltabstand und Hintergrund (weiß, 90%) in %-Abhängigkeit des Schaltabstandes

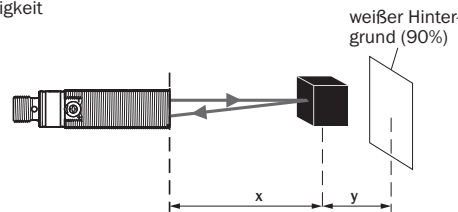
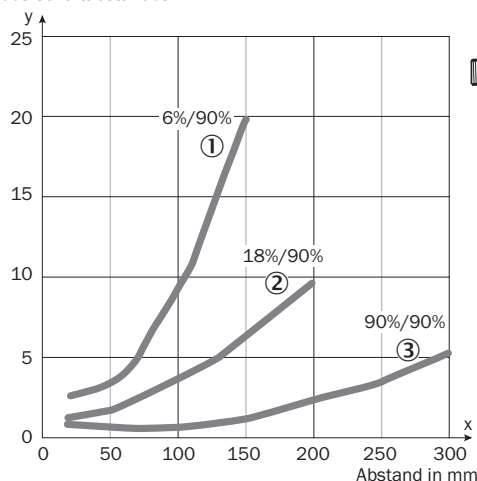

Beispiel:  
Schaltabstand auf Schwarz, 6%,  
 $x = 100 \text{ mm}$ ,  $y = (10\% \text{ von } 100 \text{ mm}) = 10 \text{ mm}$

- ① Schaltabstand auf Schwarz, 6% Remission
- ② Schaltabstand auf Grau, 18% Remission
- ③ Schaltabstand auf Weiß, 90% Remission

插图 76: 触发感应距离至 300 mm

参照插图 77 和表格 3 检查功能。如果开关量输出的表现不符合表格 3, 则须检查使用条件。参见故障诊断章节。

### 3 触发感应距离设置

无需设置传感器: 传感器已设置并准备就绪。

使用电位计 (型号: 270°) 设置触发感应距离。向右旋转: 提高触发感应距离, 向左旋转: 降低触发感应距离。我们建议使触发感应距离涵盖物体, 例如参见表格 34。触发感应距离设置完成后, 将物体从光路中移除, 同时, 将抑制背景并改变开关量输出 [参见表格 33]。

表格 34: 触发感应距离设置

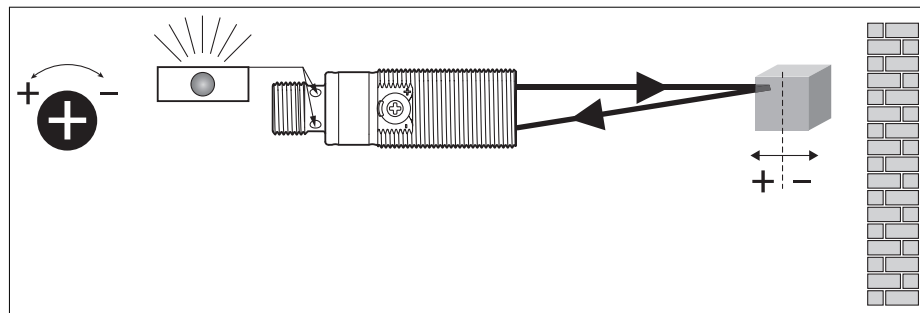

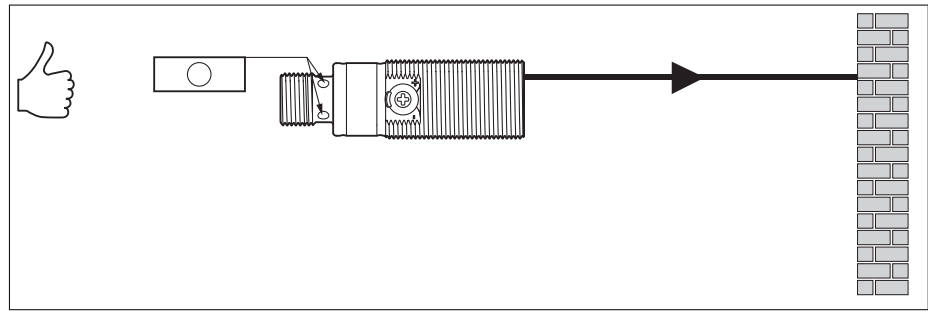

传感器已设置并准备就绪。



插图 77: 检测

## 67 故障排除

故障排除表格中罗列了传感器无法执行某项功能时应采取的各项措施。

### 67.1 故障排除表格

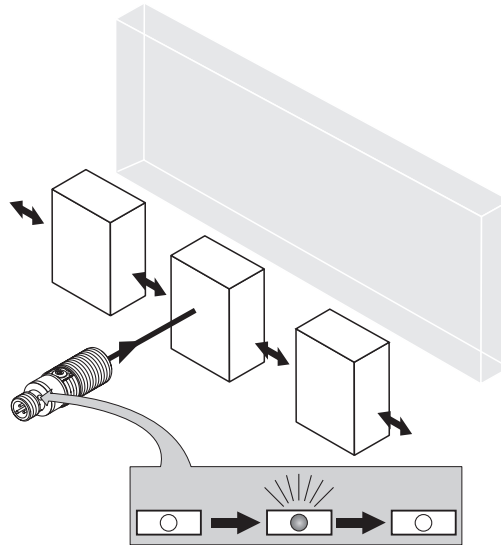
表格 35: 故障排除

LED 指示灯 / 故障界面	原因	措施
绿色 LED 未亮起	无电压或电压低于极限值	检查电源，检查整体电气连接（导线和插头连接）
绿色 LED 未亮起	电压中断	确保电源稳定无中断
绿色 LED 未亮起	传感器损坏	如果电源正常，则更换传感器
，黄色 LED 闪烁	尽管传感器准备就绪，但运行条件不佳	检查运行条件：光束（光斑）完全对准物体 / 清洁光学表面 / 重新设置灵敏度（电位计） / 检查触发感应距离，必要时调整，参见插图 76, 第 75 页
黄色 LED 亮起，光路中无物体	传感器和背景之间的间距过小	缩短触发感应距离，参见插图 76
光路中有物体，黄色 LED 未亮起	传感器和物体之间的间距过大或开关距离设置的过小	增大触发感应距离，注意传感器和背景之间的间距，参见插图 76

## 68 拆卸和废弃处理

必须根据当地特定的法律法规废弃处理传感器。如果其中含有可回收材料（尤其是贵金属），则必须在废弃处理时回收利用。

## 69 保养

SICK 传感器无需保养。

我们建议，定期：

- 清洁镜头检测面
- 检查螺栓连接和插头连接

不得对设备进行任何改装。

如有更改,不另行通知。所给出的产品特性和技术参数并非质保声明。

## 70 技术参数

	GRTB18(S)- xxx1xV	GRTB18(S)- xxx3xV	GRTB18(S)- xxx2xV
开关距离	3 ... 300 mm	3 ... 100 mm	3 ... 200 mm
最大开关距离	3 ... 300 mm <sup>1</sup>	3 ... 100 mm <sup>1</sup>	3 ... 200 mm <sup>1</sup>
可调性	电位计	不能调节	不能调节
光斑直径/距离	7 mm / 100 mm	7 mm / 100 mm	7 mm / 100 mm
供电电压 $U_V$	DC 10 ... 30 V <sup>2</sup>	DC 10 ... 30 V <sup>2</sup>	DC 10 ... 30 V <sup>2</sup>
输出电流 $I_{max}$	100 mA	100 mA	100 mA
最大开关操作顺序	1,000 Hz <sup>5</sup>	1,000 Hz <sup>5</sup>	1,000 Hz <sup>5</sup>
最长响应时间	< 0.5 ms <sup>6</sup>	< 0.5 ms <sup>6</sup>	< 0.5 ms <sup>6</sup>
防护类型	IP67,IP68,IP69K <sup>11</sup> 1	IP67,IP68,IP69K <sup>11</sup>	IP67,IP68,IP69K <sup>11</sup>
防护等级	III <sup>8</sup>	III <sup>8</sup>	III <sup>8</sup>
保护电路	A,B,D <sup>10</sup>	A,B,D <sup>10</sup>	A,B,D <sup>10</sup>
工作环境温度	-25 °C ... +55 °C	-25 °C ... +55 °C	-25 °C ... +55 °C

<sup>1</sup> Tastgut mit 90 % Remission (bezogen auf Standard-Weiß DIN 5033)

<sup>2</sup> Grenzwerte; Betrieb im kurzschlussgeschützten Netz max. 8 A; Restwelligkeit max. 5 V<sub>ss</sub>

<sup>4</sup> Gebrauchskategorie: AC-15, DC-13 (EN 60947-1)

<sup>5</sup> Mit Hell- / Dunkelverhältnis 1:1

<sup>6</sup> Signallaufzeit bei ohmscher Last

<sup>7</sup> gültig für Q\ auf Pin2, wenn per Software konfiguriert

<sup>8</sup> Bemessungsspannung DC 50 V

<sup>10</sup> A = U<sub>V</sub>-Anschlüsse verpolsicher

B = Ein- und Ausgänge verpolsicher

D = Ausgänge überstrom- und kurzschlussfest

<sup>11</sup> IP68: 根据 EN 60529 (10 m 水深 / 24 h)。

IP69K: 根据 ISO 20653: 2013-03。

# GRTB18(S)V

シリンダ型光電センサ

**SICK**  
Sensor Intelligence.

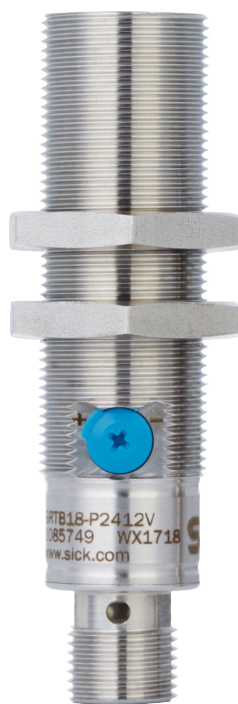

de  
en  
es  
fr  
it  
ja  
pt  
ru  
zh

## 説明されている製品

GR18 Inox  
GRTB18(S)V

## メーカー

SICK AG  
Erwin-Sick-Str. 1  
79183 Waldkirch  
Germany

## 生産拠点

SICK、マレーシア

## 法律情報

本書は著作権によって保護されています。著作権に由来するいかなる権利も SICK AG が保有しています。本書および本書の一部の複製は、著作権法の法的規定の範囲内でのみ許可されます。本書の内容を変更、削除または翻訳することは、SICK AG の書面による明確な同意がない限り禁じられています。

本書に記載されている商標は、それぞれの所有者の所有です。

© SICK AG. 無断複写・複製・転載を禁ず。

## オリジナルドキュメント

このドキュメントは SICK AG のオリジナルドキュメントです。





## コンテンツ

71	安全上の注意事項.....	82
72	正しいご使用方法.....	82
73	操作/表示要素.....	82
74	取付.....	83
75	電子装備.....	84
76	コミッショニング.....	85
77	トラブルシューティング.....	87
	77.1 トラブルシューティング表.....	87
78	解体および廃棄.....	88
79	メンテナンス.....	88
80	技術仕様.....	89

## 71 安全上の注意事項

- コミッショニング前に取扱説明書をお読みください。
-  接続、取付けおよび設定できるのは専門技術者に限ります。
- 本製品は EU 機械指令の要件を満たす安全コンポーネントではありません。
- Power supply: Class 2  
Enclosure type 1
- コミッショニングの際には、装置が濡れたり汚れたりしないように保護してください。
- 本取扱説明書には、センサのライフサイクル中に必要となる情報が記載されています。

## 72 正しいご使用方法

GRTB18(S)V とはリフレクタ形光電スイッチ（以下センサと呼ぶ）で、物体、動物または人物などを光学技術により非接触で検知するための装置です。製品を用途以外の目的で使用したり改造したりした場合は、SICK AG に対する一切の保証請求権が無効になります。

## 73 操作/表示要素

背景抑制付きリフレクタ形光電スイッチ

表 36: 寸法図面



図 78: ショート形状、接続ケーブル

図 79: ショート形状、M12 オスコネクタ

図 80: ショート形状、ポテンシオメータ、接続ケーブル

図 81: ショート形状、ポテンシオメータ、M12 オスコネクタ

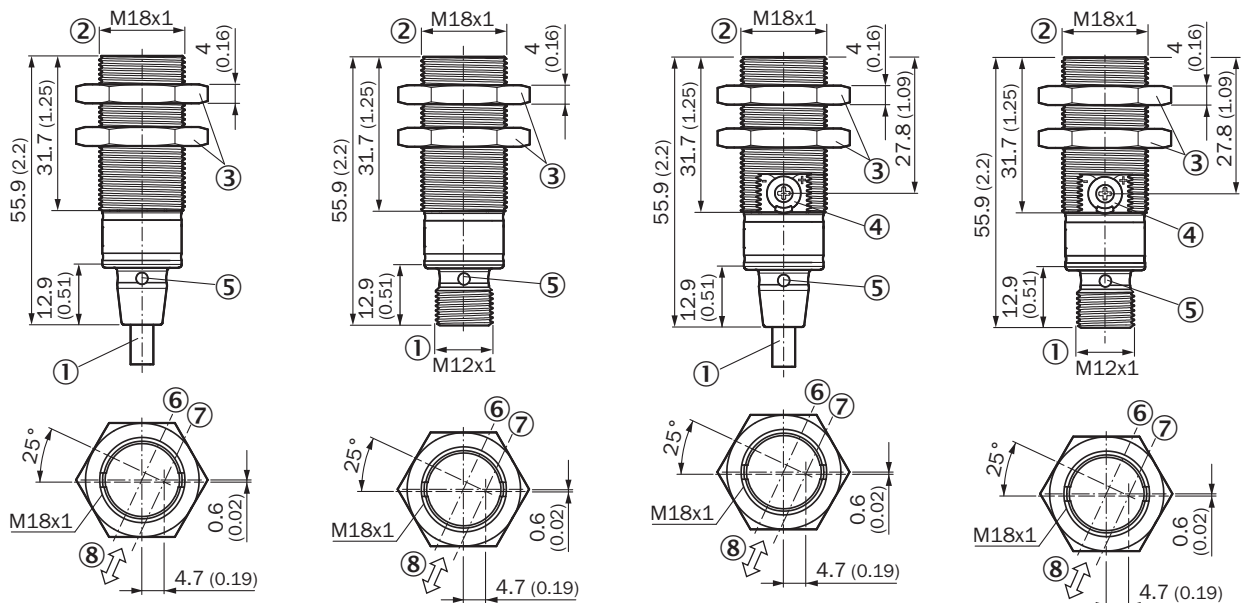

図 82: ロング形状、接続ケーブル

図 83: ロング形状、M12 オスコネクタ

図 84: ロング形状、ポテンシヨメータ、接続ケーブル

図 85: ロング形状、ポテンシヨメータ、M12 オスコネクタ

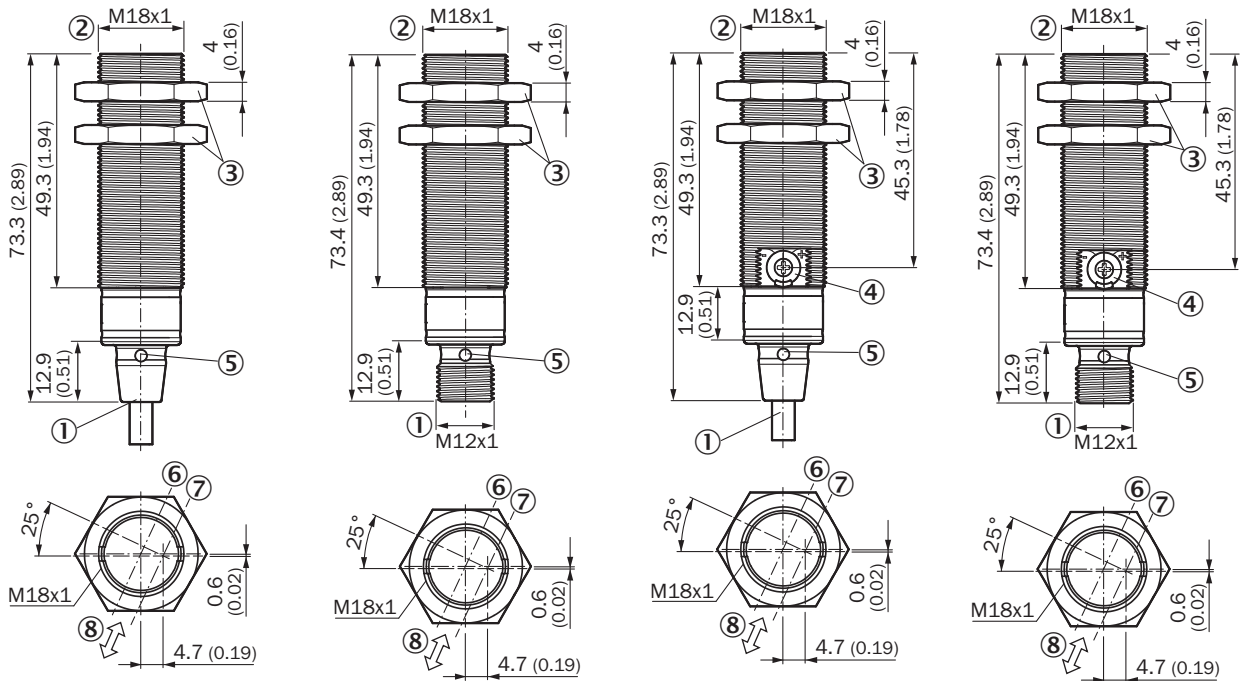
- ① 接続
- ② 取付ネジ M18 x 1
- ③ 固定ナット (2 x); WS24、ステンレススチール
- ④ ポテンシヨメータ、270°
- ⑤ LED 表示 (4 x)
- ⑥ 光軸、受光器
- ⑦ 光軸、投光器
- ⑧ 優先方向



図 86: 操作要素: 検出距離

## 74 取付

センサを適切な取付ブラケットに取付けます (SICK 付属品カタログを参照)。

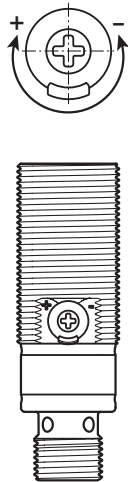
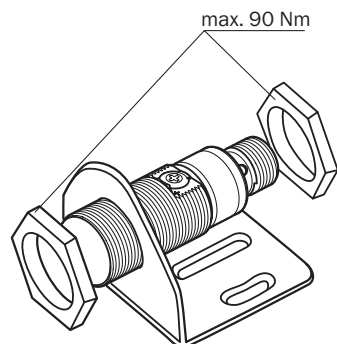

センサの締付トルクの最大許容値 90 Nm を遵守してください。

センサに対して対象物が検出可能な方向にあることを確認してください: [表 36](#) を参照。

## 75 電子装備

センサの接続は無電圧 ( $U_v = 0 \text{ V}$ ) で行わなければなりません。接続タイプに応じて以下の情報を遵守してください:

- コネクタ接続: ピン配置
- ケーブル: 芯線色

すべての電気機器を接続してから供給電圧 ( $V_s > 0 \text{ V}$ ) を印加、あるいは電源を入れてください。センサの緑色の LED 表示が点灯します。

配線図の説明 (表 2 および 3):

$Q / \bar{Q}$  = スイッチング出力

n. c. = 未接続

**DC: 10... 30 V DC、参照 „技術仕様“, ページ 89**

表 37: DC

GRTB18(S)V	x11xxx	x13xxx	x24xxx	x23xxx
1	+ (L+)	+ (L+)	+ (L+)	+ (L+)
2	$\bar{Q}$	n. c.	$\bar{Q}$	n. c.
3	- (M)	- (M)	- (M)	- (M)
4	Q	Q	Q	Q
	 1 = 茶 2 = 白 3 = 青 4 = 黒 0.14 mm <sup>2</sup> AWG26	 1 = 茶 - 3 = 青 4 = 黒 0.14 mm <sup>2</sup> AWG26		

表 38: DC

		
PNP: Q ( $\leq 100$ mA)		
NPN: Q ( $\leq 100$ mA)		
PNP: $\bar{Q}$ ( $\leq 100$ mA)		
NPN: $\bar{Q}$ ( $\leq 100$ mA)		

## 76 コミッショニング

### 1 光軸調整

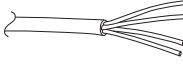
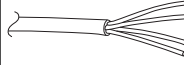
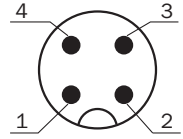
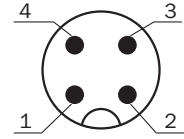
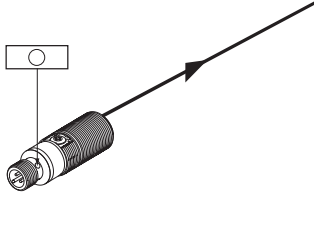
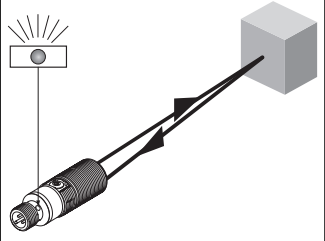
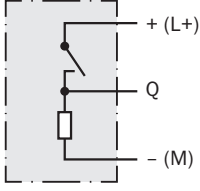
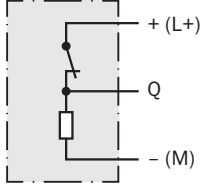
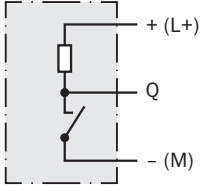
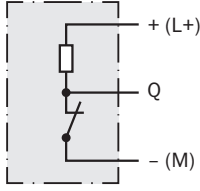
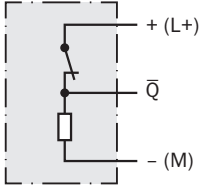
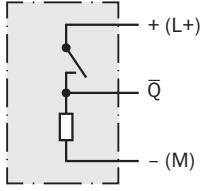
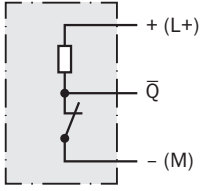
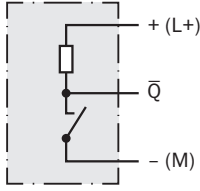
センサを対象物に合わせて光軸調整します。赤色の投光軸が対象物の中央に照射されるように位置決めします。センサの光開口 (フロントカバー) が全く遮らざれることがないように注意してください [参照 図]。



図: 光軸調整

### 2 検出距離

使用条件を確認してください: 検出距離と対象物または背景との間隔、ならびに対象物の反射率を対応する図 [参照 図 87] と照合します ( $x$  = 検出距離、 $y$  = 設定した検出距離と検出距離の%としての背景抑制との間の遷移領域 (対象物反射率 / 背景反射率))。反射率: 6% = 黒色 ①、18% = 灰色 ②、90% = 白色 ③ (DIN 5033 に準拠した白)。反射率の低い対象物を使用して調整することをお勧めします。

背景抑制のための最小距離 (=  $y$ ) は図 [参照 図 87 ①] から以下のように読み取ることができます:

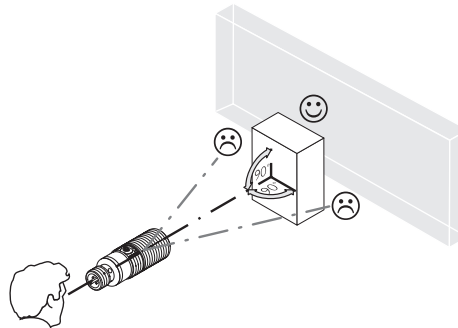
例:  $x = 150 \text{ mm}$ 、 $y = 20 \Rightarrow 150 \text{ mm} = 30 \text{ mm}$  のうち 20%。つまりセンサからの間隔が 180 mm より大きい場合に背景が抑制されます。

Mindestabstand in mm ( $y$ ) zwischen eingestelltem Schaltabstand und Hintergrund (weiß, 90%) in %-Abhängigkeit des Schaltabstandes

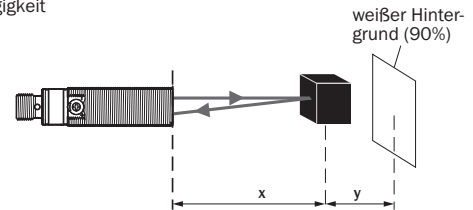
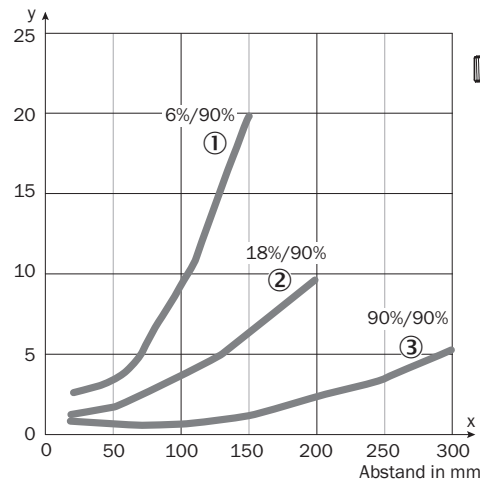

Beispiel:

Schaltabstand auf Schwarz, 6%,

$x = 100 \text{ mm}$ ,  $y = (10\% \text{ von } 100 \text{ mm}) = 10 \text{ mm}$

- ① Schaltabstand auf Schwarz, 6% Remission
- ② Schaltabstand auf Grau, 18% Remission
- ③ Schaltabstand auf Weiß, 90% Remission

図 87: 最大検出距離 300 mm

機能を点検するために、図 88 と表 3 を使用します。スイッチング出力が表 3 に従った動作を示さない場合は、使用条件を確認してください。故障診断の項目を参照。

### 3 検出距離の設定

設定不要なセンサ: センサは設定され、動作準備が整っています。

ポテンシオメータ (タイプ: 270°) で検出距離を設定します。右へ回すと検出距離が増大、左へ回すと検出距離が減少します。検出距離を対象物内に入れることをお勧めします。例: 参照表 39。検出距離が設定された後、対象物を光路から取り除きます。この際、背景は抑制され、スイッチング出力が変化します [参照表 38]。

表 39: 検出距離の設定

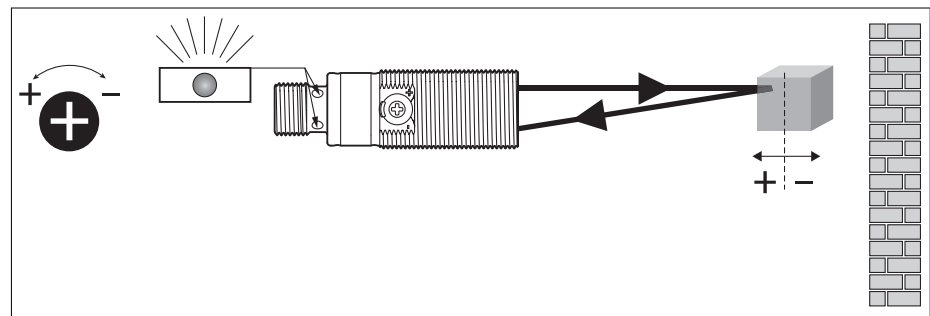

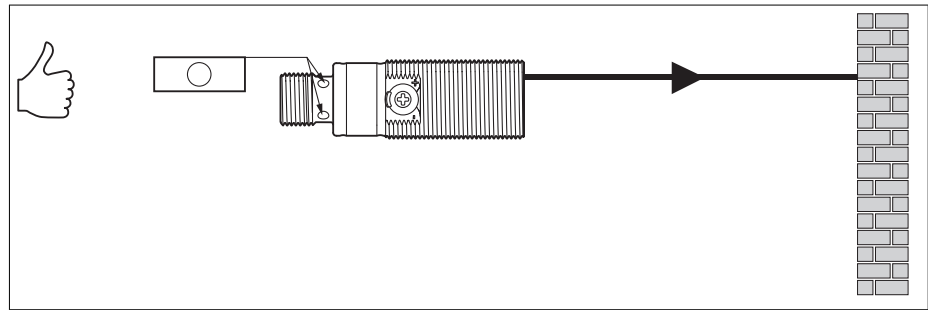

センサは設定され動作準備が整いました。



図 88: 検出

## 77 トラブルシューティング

トラブルシューティングの表は、センサが機能しなくなった場合に、どのような対策を講じるべきかを示しています。

### 77.1 トラブルシューティング表

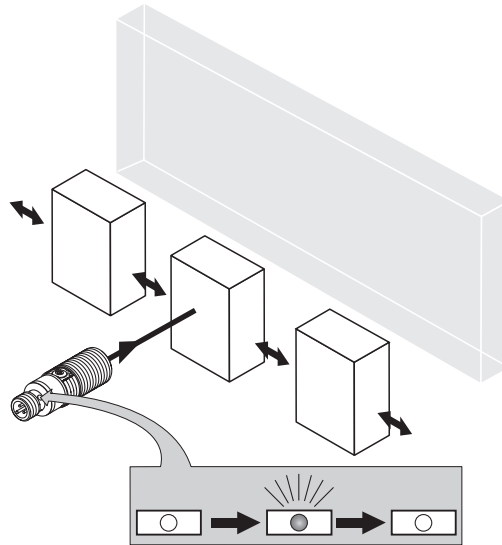
表 40: トラブルシューティング

LED 表示灯/故障パターン	原因	対策
緑色の LED が点灯しない	無電圧、または電圧が限界値以下	電源を確認し、すべての電気接続（ケーブルおよびプラグ接続）を確認します
緑色の LED が点灯しない	電圧がきていない又は不安定	安定した電源電圧が供給されていることを確認します
緑色の LED が点灯しない	センサの異常	電源に問題がなければ、センサを交換します
黄色い LED が点滅	センサの動作準備はまだ整っているが、動作条件が最適ではない	動作条件の点検: 光軸 (光軸スポット) を完全に対象物に合わせます。 / 光学面の洗浄 / 感度 (ポテンシオメータ) を新規設定 / 検出距離を点検し、必要に応じて調整する、参照 図 87, ページ 86

LED 表示灯/故障パターン	原因	対策
黄色い LED が点灯、光軸に対象物がない	センサと背景の間隔が短すぎる	検出距離を縮小する、 <a href="#">参照 図 87</a>
対象物は光軸にある、黄色い LED は点灯しない	センサと対象物の間隔が長すぎる、または検出範囲の設定が短すぎる	センサと背景間の距離に注意して検出距離を拡大する、 <a href="#">参照 図 87</a>

## 78 解体および廃棄

センサは必ず該当国の規制にしたがって処分してください。廃棄処理の際には、できるだけ構成材料をリサイクルするよう努めてください（特に貴金属類）。

## 79 メンテナンス

SICK センサはメンテナンスフリーです。

定期的に以下を行うことをお勧めしています：

- ・ レンズ境界面の清掃
- ・ ネジ締結と差込み締結の点検

機器を改造することは禁止されています。

記載内容につきましては予告なしに変更する場合がございますのであらかじめご了承ください。指定された製品特性および技術データは保証書ではありません。



## 80 技術仕様

	GRTB18(S)- xxx1xV	GRTB18(S)- xxx3xV	GRTB18(S)- xxx2xV
検出範囲	3 ... 300 mm	3 ... 100 mm	3 ... 200 mm
最大検出範囲	3 ... 300 mm <sup>1</sup>	3 ... 100 mm <sup>1</sup>	3 ... 200 mm <sup>1</sup>
設定方法	ポテンショメータ	設定方法なし	設定方法なし
光点のスポット径/距離	7 mm / 100 mm	7 mm / 100 mm	7 mm / 100 mm
供給電圧 U <sub>v</sub>	DC 10 ... 30 V <sup>2</sup>	DC 10 ... 30 V <sup>2</sup>	DC 10 ... 30 V <sup>2</sup>
出力電流 I <sub>max</sub>	100 mA	100 mA	100 mA
最大スイッチング周波数	1,000 Hz <sup>5</sup>	1,000 Hz <sup>5</sup>	1,000 Hz <sup>5</sup>
最大応答時間	< 0.5 ms <sup>6</sup>	< 0.5 ms <sup>6</sup>	< 0.5 ms <sup>6</sup>
保護等級	IP67,IP68,IP69K <sup>11</sup> 1	IP67,IP68,IP69K <sup>11</sup>	IP67,IP68,IP69K <sup>11</sup>
保護クラス	III <sup>8</sup>	III <sup>8</sup>	III <sup>8</sup>
回路保護	A,B,D <sup>10</sup>	A,B,D <sup>10</sup>	A,B,D <sup>10</sup>
周辺温度 (作動中)	-25 °C ... +55 °C	-25 °C ... +55 °C	-25 °C ... +55 °C

<sup>1</sup> Tastgut mit 90 % Remission (bezogen auf Standard-Weiß DIN 5033)

<sup>2</sup> Grenzwerte; Betrieb im kurzschlussgeschützten Netz max. 8 A; Restwelligkeit max. 5 V<sub>ss</sub>

<sup>4</sup> Gebrauchskategorie: AC-15, DC-13 (EN 60947-1)

<sup>5</sup> Mit Hell- / Dunkelverhältnis 1:1

<sup>6</sup> Signallaufzeit bei ohmscher Last

<sup>7</sup> gültig für Q\ auf Pin2, wenn per Software konfiguriert

<sup>8</sup> Bemessungsspannung DC 50 V

<sup>10</sup> A = U<sub>v</sub>-Anschlüsse verpolsicher

B = Ein- und Ausgänge verpolsicher

D = Ausgänge überstrom- und kurzschlussfest

<sup>11</sup> IP68: EN 60529 に準拠 (水深 10 m / 24 h)。

IP69K: Nach ISO 20653:2013-03.

# GRTB18(S)V

Цилиндрические фотоэлектрические датчики

**SICK**  
Sensor Intelligence.



de  
en  
es  
fr  
it  
ja  
pt  
ru  
zh

### Описание продукта

GR18 Inox  
GRTB18(S)V

### Изготовитель

SICK AG  
Erwin-Sick-Str. 1  
79183 Waldkirch  
Deutschland (Германия)

### Место изготовления

SICK, Малайзия

### Правовые примечания

Данная документация защищена авторским правом. Обоснованные таким образом права сохраняются за фирмой SICK AG. Тиражирование документации или ее части допускается только в рамках положений закона об авторских правах. Внесение в документацию изменений, сокращение или перевод ее содержимого без однозначного письменного согласия фирмы SICK AG запрещено.

Товарные знаки, упомянутые в данном документе, являются собственностью соответствующего владельца.

© SICK AG Все права защищены.

### Оригинальный документ

Настоящий документ является оригинальным документом SICK AG.



**Содержание**

<b>81</b>	<b>Указания по технике безопасности.....</b>	<b>93</b>
<b>82</b>	<b>Применение по назначению.....</b>	<b>93</b>
<b>83</b>	<b>Элементы управления и индикаторы.....</b>	<b>93</b>
<b>84</b>	<b>Монтаж.....</b>	<b>94</b>
<b>85</b>	<b>Подключение электроники.....</b>	<b>95</b>
<b>86</b>	<b>Ввод в эксплуатацию.....</b>	<b>96</b>
<b>87</b>	<b>Устранение неисправностей.....</b>	<b>98</b>
	87.1 Таблица устранения неисправностей.....	98
<b>88</b>	<b>Демонтаж и утилизация.....</b>	<b>99</b>
<b>89</b>	<b>Техобслуживание.....</b>	<b>99</b>
<b>90</b>	<b>Технические характеристики.....</b>	<b>100</b>

## 81 Указания по технике безопасности

- Перед вводом в эксплуатацию изучите руководство по эксплуатации.
-  Подключение, монтаж и установку поручать только специалистам.
- Данное устройство не является оборудованием для обеспечения безопасности в соответствии с Директивой ЕС по машинному оборудованию.
- Power supply: Class 2  
Enclosure type 1
- При вводе в эксплуатацию следует защитить устройство от попадания влаги и грязи.
- В данном руководстве по эксплуатации содержится информация, необходимая на протяжении всего жизненного цикла датчика.

## 82 Применение по назначению

GRTB18(S)V является фотоэлектрическим датчиком диффузионного типа (в дальнейшем называемым «датчик») и используется для оптической бесконтактной регистрации предметов, животных и людей. В случае использования устройства для иных целей, а также в случае внесения в изделие изменений, любые претензии к компании SICK AG на предоставление гарантии исключаются.

## 83 Элементы управления и индикаторы

Фотоэлектрический датчик диффузионного типа с подавлением заднего фона.

Таблица 41: Габаритные чертежи



Рисунок 89: Короткий вариант, соединительный кабель



Рисунок 90: Короткий вариант, разъем M12

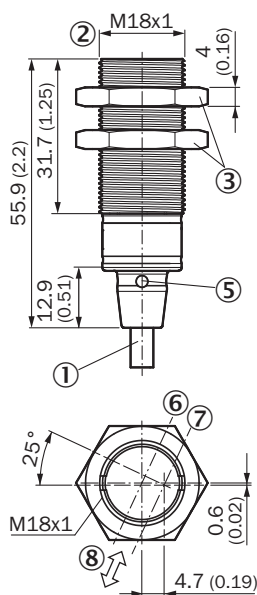

Рисунок 91: Короткий вариант, потенциометр, соединительный кабель

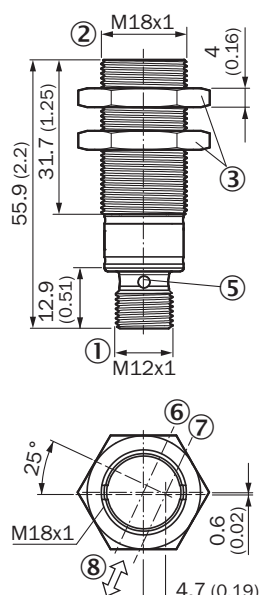

Рисунок 92: Короткий вариант, потенциометр, разъем M12

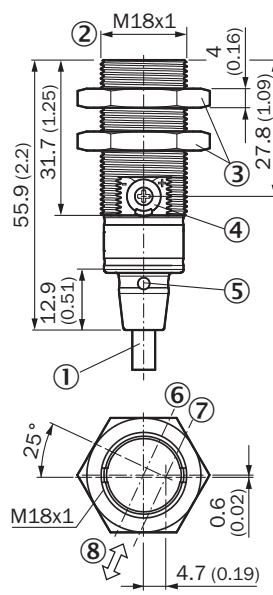

Рисунок 93: Длинный вариант, соединительный кабель

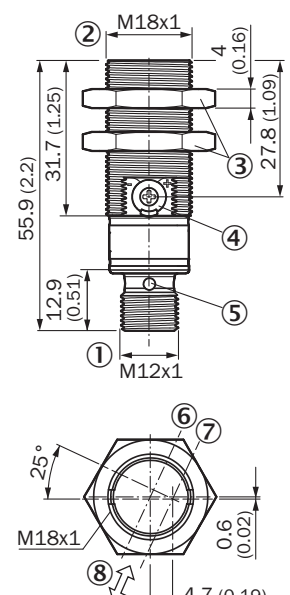

Рисунок 94: Длинный вариант, разъем M12

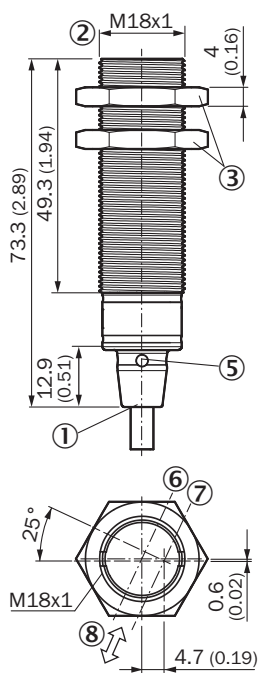

Рисунок 95: Длинный вариант, потенциометр, соединительный кабель

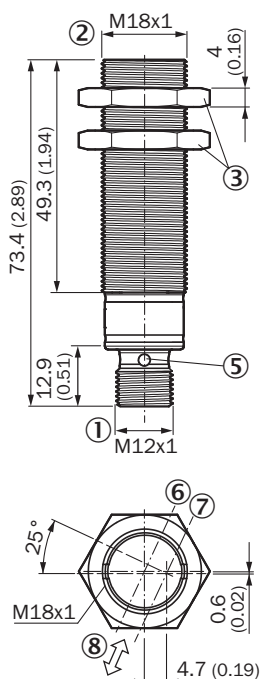

Рисунок 96: Длинный вариант, потенциометр, разъем M12

- ① Соединение
- ② Крепежная резьба M18 x 1
- ③ Крепежная гайка (2 x); WS24, нержавеющая сталь
- ④ Потенциометр, 270°
- ⑤ Светодиодный индикатор (4 штуки)
- ⑥ Оптическая ось, приемник
- ⑦ Оптическая ось, передатчик
- ⑧ Предпочтительное направление

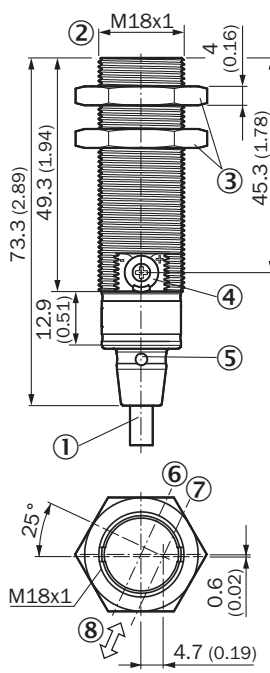

Рисунок 97: Элемент управления: расстояние срабатывания

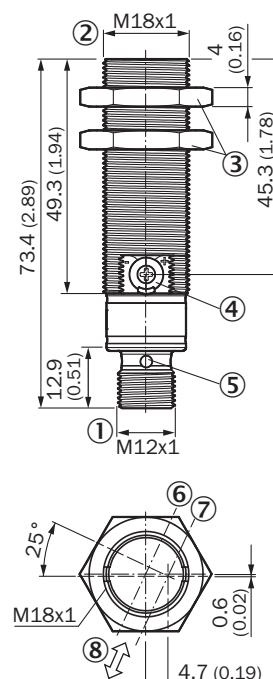
## 84 Монтаж

Установите датчик на подходящем крепежном уголке (см. программу принадлежностей от SICK).

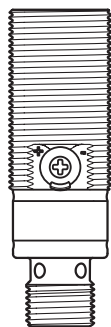
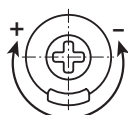
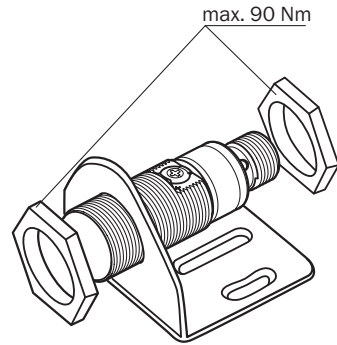

Выдерживайте максимально допустимый момент затяжки датчика в 90 Нм.

Учитывать предпочтительное направление объекта относительно датчика [таблица 41](#).

## 85 Подключение электроники

Подключение датчиков должно производиться при отключенном напряжении питания ( $U_V = 0\text{ В}$ ). В зависимости от типа подключения следует принять во внимание следующую информацию:

- Штепсельный разъём: расположение выводов
- Кабель: цвет жилы

Подавать напряжение питания и включать источник напряжения только после завершения подключения всех электрических соединений ( $U_V > 0\text{ В}$ ). На датчике загорается зелёный светодиодный индикатор.

Пояснения к схеме подключений (таблицы 2 и 3):

Q /  $\bar{Q}$  = переключающие выходы

n. c. = не подключен

**DC: 10 ... 30 В пост. тока см. „Технические характеристики“, страница 100**

Таблица 42: пост. ток

GRTB18(S)V	x11xxx	x13xxx	x24xxx	x23xxx
1	+ (L+)	+ (L+)	+ (L+)	+ (L+)
2	$\bar{Q}$	n. c.	$\bar{Q}$	n. c.
3	- (M)	- (M)	- (M)	- (M)
4	Q	Q	Q	Q
	<p>1 = brn (коричневый)                      2 = wht (белый)                      3 = blu (синий)                      4 = blk (черный)                      0,14 мм<sup>2</sup>                      AWG26</p>	<p>1 = brn (коричневый)                      -                      3 = blu (синий)                      4 = blk (черный)                      0,14 мм<sup>2</sup>                      AWG26</p>		

Таблица 43: пост. ток

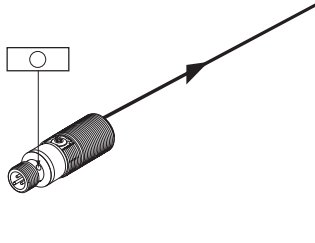
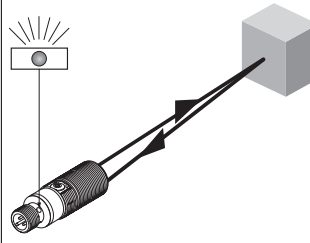
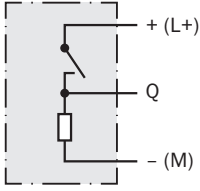
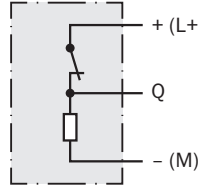
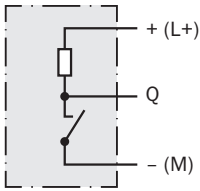
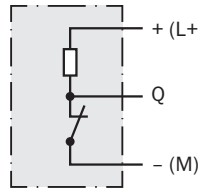
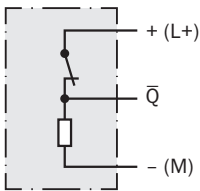
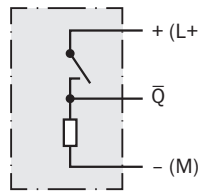
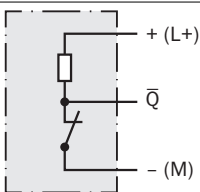
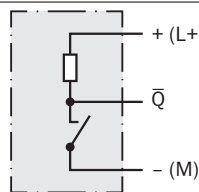
		
PNP: Q ( $\leq 100$ mA)		
NPN: Q ( $\leq 100$ mA)		
PNP: Q-bar ( $\leq 100$ mA)		
NPN: Q-bar ( $\leq 100$ mA)		

## 86 Ввод в эксплуатацию

### 1 Выравнивание

Произвести выверку датчика по одной оси с объектом. Выберите такую позицию, чтобы красный луч передатчика попадал в центр объекта. Оптическое отверстие (фронтальное стекло) на датчике должно быть полностью свободным [см. рисунок].



Рисунок: Выравнивание

### 2 Расстояние срабатывания

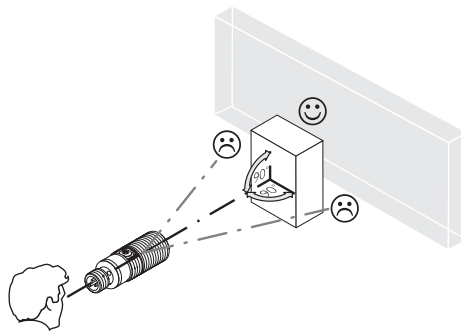

Проверить условия применения: скорректировать расстояние срабатывания и дистанцию до объекта / фона, а также яркость объекта с помощью соответствующей диаграммы [см. рисунок 98] (x = расстояние срабатывания, y = контролируемая зона между установленным расстоянием срабатывания и подавлением заднего фона в % расстояния срабатывания (коэффициент диффузного отражения объекта / коэффициент диффузного отражения фона)). Коэффициент диффузного отражения: 6 % = чёрный ①, 18 % = серый ②, 90 % = белый ③ (относительно стандартного белого по DIN 5033). Мы рекомендуем выполнять настройку с объектом, имеющим низкий коэффициент диффузного отражения.

Минимальную дистанцию (= y) для затемнения фона можно определить по диаграмме [см. рисунок 98 ①] следующим образом:

Пример: x = 150 мм, y = 20 => 20 % от 150 мм = 30 мм. То есть, фон затемняется при расстоянии > 180 мм от датчика.

Mindestabstand in mm (y) zwischen eingestelltem Schaltabstand und Hintergrund (weiß, 90%) in %-Abhängigkeit des Schaltabstandes

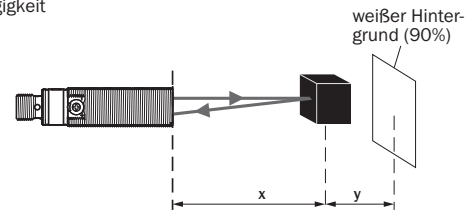
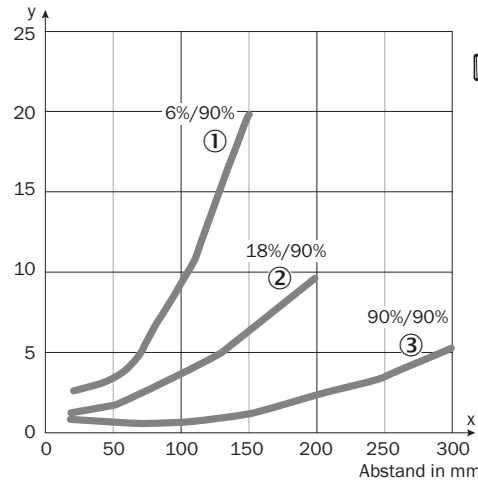

Beispiel:  
Schaltabstand auf Schwarz, 6%,  
x = 100 mm, y = (10% von 100 mm) = 10 mm

- ① Schaltabstand auf Schwarz, 6% Remission
- ② Schaltabstand auf Grau, 18% Remission
- ③ Schaltabstand auf Weiß, 90% Remission

Рисунок 98: Расстояние срабатывания до 300 мм

Для проверки функционирования воспользуйтесь [рисунок 99](#) и таблицей 3. Если характер поведения переключающего выхода не соответствует Таблице 3, проверить условий эксплуатации. См. раздел «Диагностика неисправностей».

### 3 Настройка расстояния срабатывания

Датчик без возможности настройки: датчик настроен и готов к эксплуатации.

Расстояние срабатывания регулируется с помощью потенциометра (тип: 270°). Вращение вправо: увеличение расстояния срабатывания, вращение влево: уменьшение расстояния срабатывания. Мы рекомендуем устанавливать расстояние срабатывания в объекте, например, [см. таблица 44](#). После настройки расстояния срабатывания, удалить объект с траектории луча, при этом затемняется фон и изменяется переключающий выход [[см. таблица 43](#)].

Таблица 44: Настройка расстояния срабатывания

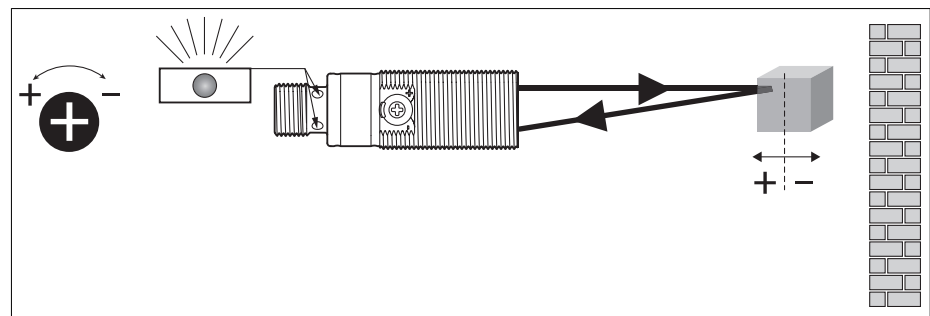

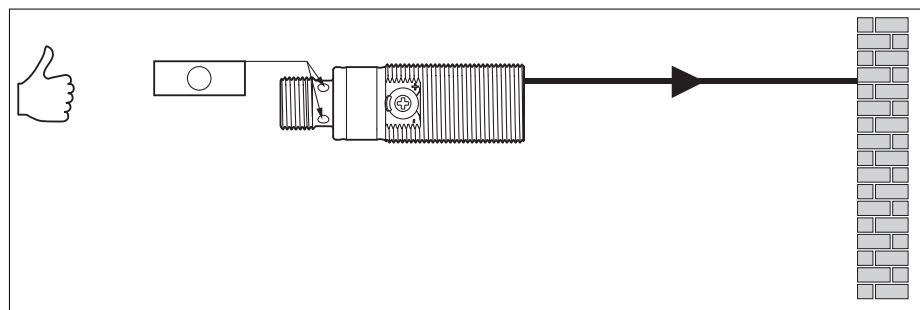

Датчик настроен и готов к эксплуатации.



Рисунок 99: Обнаружение

## 87 Устранение неисправностей

В таблице Устранение неисправностей показано, какие меры необходимо предпринять, если датчики не работают.

### 87.1 Таблица устранения неисправностей

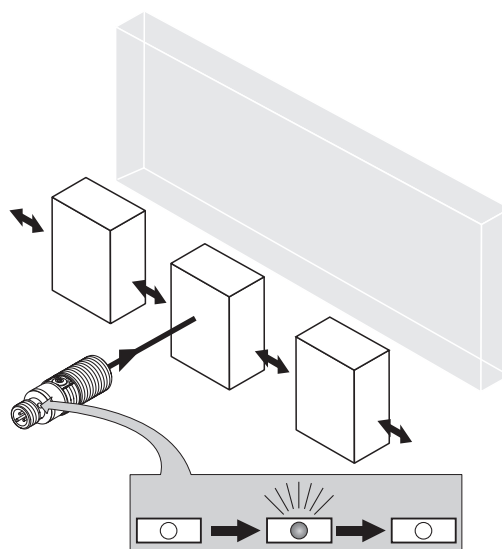
Таблица 45: Устранение неисправностей

Светодиодный индикатор / картина неисправности	Причина	Меры по устранению
зеленый светодиод не горит	нет напряжения питания или оно ниже нижнего предельного значения	Проверить напряжения питания, всю схему электроподключения (проводку и разъемные соединения)
зеленый светодиод не горит	Пропадание напряжения питания	Обеспечить надежную подачу напряжения питания без его пропадания
зеленый светодиод не горит	Сенсор неисправен	Если напряжение питания в порядке, то заменить сенсор
желтый светодиод мигает	Сенсор пока еще готов к работе, но эксплуатационные условия не оптимальны	Проверить эксплуатационные условия: Полностью сориентировать световой луч (световое пятно) на объект / чистка оптических поверхностей / заново настроить чувстви-

Светодиодный индикатор / картина неисправности	Причина	Меры по устранению
		тельность (потенциометром) / проверить и, при необходимости, скорректировать расстояние срабатывания, см. рисунок 98, страница 97
желтый светодиод горит, объект на пути луча отсутствует	Расстояние между сенсором и фоном слишком мало	Уменьшить расстояние срабатывания, см. рисунок 98
Объект на пути луча, желтый светодиод не горит	Слишком большое расстояние между сенсором и объектом или установлена слишком малая дистанция переключения	Увеличить расстояние срабатывания, соблюдать расстояние между датчиком и фоном, см. рисунок 98

## 88 Демонтаж и утилизация

Утилизацию сенсоров следует проводить согласно национальным предписаниям по утилизации. Следует стремиться к повторному использованию содержащихся в них материалов (прежде всего, драгоценных металлов).

## 89 Техобслуживание

Датчики SICK не нуждаются в техобслуживании.

Рекомендуется регулярно

- очищать оптические ограничивающие поверхности
- проверять прочность резьбовых и штекерных соединений

Запрещается вносить изменения в устройства.

Право на ошибки и внесение изменений сохранено. Указанные свойства изделия и технические характеристики не являются гарантией.

## 90 Технические характеристики

	GRTB18(S)-xxx1xV	GRTB18(S)-xxx3xV	GRTB18(S)-xxx2xV
Расстояние срабатывания	3 ... 300 mm	3 ... 100 mm	3 ... 200 mm
Расстояние срабатывания, макс.	3 ... 300 mm <sup>1</sup>	3 ... 100 mm <sup>1</sup>	3 ... 200 mm <sup>1</sup>
вариант настройки	Потенциометр	отсутствует возможность настройки	отсутствует возможность настройки
Диаметр светового пятна/расстояние	7 mm / 100 mm	7 mm / 100 mm	7 mm / 100 mm
Напряжение питания $U_V$	DC 10 ... 30 V <sup>2</sup>	DC 10 ... 30 V <sup>2</sup>	DC 10 ... 30 V <sup>2</sup>
Выходной ток $I_{\text{макс.}}$	100 mA	100 mA	100 mA
Частота срабатывания макс.	1,000 Hz <sup>5</sup>	1,000 Hz <sup>5</sup>	1,000 Hz <sup>5</sup>
Время отклика макс.	< 0.5 ms <sup>6</sup>	< 0.5 ms <sup>6</sup>	< 0.5 ms <sup>6</sup>
Класс защиты	IP67,IP68,IP69K <sup>11</sup>	IP67,IP68,IP69K <sup>11</sup>	IP67,IP68,IP69K <sup>11</sup>
Класс защиты	III <sup>8</sup>	III <sup>8</sup>	III <sup>8</sup>
Схемы защиты	A,B,D <sup>10</sup>	A,B,D <sup>10</sup>	A,B,D <sup>10</sup>
Диапазон рабочих температур	-25 °C ... +55 °C	-25 °C ... +55 °C	-25 °C ... +55 °C

<sup>1</sup> Tastgut mit 90 % Remission (bezogen auf Standard-Weiß DIN 5033)

<sup>2</sup> Grenzwerte; Betrieb im kurzschlussgeschützten Netz max. 8 A; Restwelligkeit max. 5 V<sub>ss</sub>

<sup>4</sup> Gebrauchskategorie: AC-15, DC-13 (EN 60947-1)

<sup>5</sup> Mit Hell- / Dunkelverhältnis 1:1

<sup>6</sup> Signallaufzeit bei ohmscher Last

<sup>7</sup> gültig für Q\ auf Pin2, wenn per Software konfiguriert

<sup>8</sup> Bemessungsspannung DC 50 V

<sup>10</sup> A = U<sub>V</sub>-Anschlüsse verpolsicher

B = Ein- und Ausgänge verpolsicher

D = Ausgänge überstrom- und kurzschlussfest

<sup>11</sup> IP68: согласно EN 60529 (глубина воды 10 м / 24 ч).

IP69K: согласно ISO 20653:2013-03.

**Australia**

Phone +61 3 9457 0600  
1800 334 802 - tollfree  
E-Mail sales@sick.com.au

**Austria**

Phone +43 22 36 62 28 8-0  
E-Mail office@sick.at

**Belgium/Luxembourg**

Phone +32 2 466 55 66  
E-Mail info@sick.be

**Brazil**

Phone +55 11 3215-4900  
E-Mail marketing@sick.com.br

**Canada**

Phone +1 905 771 14 44  
E-Mail information@sick.com

**Czech Republic**

Phone +420 2 57 91 18 50  
E-Mail sick@sick.cz

**Chile**

Phone +56 2 2274 7430  
E-Mail info@schadler.com

**China**

Phone +86 20 2882 3600  
E-Mail info.china@sick.net.cn

**Denmark**

Phone +45 45 82 64 00  
E-Mail sick@sick.dk

**Finland**

Phone +358-9-2515 800  
E-Mail sick@sick.fi

**France**

Phone +33 1 64 62 35 00  
E-Mail info@sick.fr

**Germany**

Phone +49 211 5301-301  
E-Mail info@sick.de

**Hong Kong**

Phone +852 2153 6300  
E-Mail ghk@sick.com.hk

**Hungary**

Phone +36 1 371 2680  
E-Mail office@sick.hu

**India**

Phone +91 22 6119 8900  
E-Mail info@sick-india.com

**Israel**

Phone +972 4 6881000  
E-Mail info@sick-sensors.com

**Italy**

Phone +39 02 274341  
E-Mail info@sick.it

**Japan**

Phone +81 3 5309 2112  
E-Mail support@sick.jp

**Malaysia**

Phone +6 03 8080 7425  
E-Mail enquiry.my@sick.com

**Mexico**

Phone +52 (472) 748 9451  
E-Mail mario.garcia@sick.com

**Netherlands**

Phone +31 30 2044 000  
E-Mail info@sick.nl

**New Zealand**

Phone +64 9 415 0459  
0800 222 278 - tollfree  
E-Mail sales@sick.co.nz

**Norway**

Phone +47 67 81 50 00  
E-Mail sick@sick.no

**Poland**

Phone +48 22 539 41 00  
E-Mail info@sick.pl

**Romania**

Phone +40 356 171 120  
E-Mail office@sick.ro

**Russia**

Phone +7 495 775 05 30  
E-Mail info@sick.ru

**Singapore**

Phone +65 6744 3732  
E-Mail sales.gsg@sick.com

**Slovakia**

Phone +421 482 901201  
E-Mail mail@sick-sk.sk

**Slovenia**

Phone +386 591 788 49  
E-Mail office@sick.si

**South Africa**

Phone +27 11 472 3733  
E-Mail info@sickautomation.co.za

**South Korea**

Phone +82 2 786 6321  
E-Mail info@sickkorea.net

**Spain**

Phone +34 93 480 31 00  
E-Mail info@sick.es

**Sweden**

Phone +46 10 110 10 00  
E-Mail info@sick.se

**Switzerland**

Phone +41 41 619 29 39  
E-Mail contact@sick.ch

**Taiwan**

Phone +886 2 2375-6288  
E-Mail sales@sick.com.tw

**Thailand**

Phone +66 2645 0009  
E-Mail Ronnie.Lim@sick.com

**Turkey**

Phone +90 216 528 50 00  
E-Mail info@sick.com.tr

**United Arab Emirates**

Phone +971 4 88 65 878  
E-Mail info@sick.ae

**United Kingdom**

Phone +44 1727 831121  
E-Mail info@sick.co.uk

**USA**

Phone +1 800 325 7425  
E-Mail info@sick.com

**Vietnam**

Phone +84 945452999  
E-Mail Ngo.Duy.Linh@sick.com

Further locations at [www.sick.com](http://www.sick.com)

