

## Datasheet

Radars-Based Dual-Zone Narrow-Beam Sensors for Detection of Moving and Stationary Targets

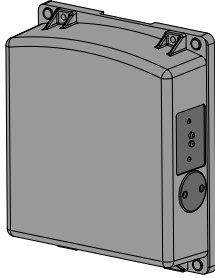

- FMCW (true-presence) radar detects moving and stationary objects
- Narrow 11° × 13° beam pattern
- Analog and discrete outputs for measuring objects up to 100 m (328.1 ft) away
- Easy setup and configuration of range, sensitivity, and output with simple DIP switches
- Sensing functions are unaffected by wind, falling rain or snow, fog, humidity, air temperatures, or light
- Sensor operates in Industrial, Scientific, and Medical (ISM) telecommunication band
- Rugged IP67 housing withstands harsh environments

Protected by US patents



**CAUTION:** Make No **Modifications** to this Product

Any modifications to this product not expressly approved by Banner Engineering could void the user's authority to operate the product. Contact Banner Engineering for more **information**.



**WARNING:** Not To Be Used for Personnel **Protection**

Never use this device as a sensing device for personnel **protection**. Doing so could lead to serious injury or death. This device does not include the self-checking redundant circuitry necessary to allow its use in personnel safety applications. A sensor failure or malfunction can cause either an energized or de-energized sensor output condition.

## Models

Model	Sensing Range	Connection	Supply Voltage	Telecom Approval	Output
Q240RA-CN-ILO	Discrete output: 1 m to 100 m (3.3 ft to 328 ft) Analog output: 3.5 m to 100 m (11.5 ft to 328 ft)	5-pin M12 quick disconnect	12 V dc to 30 V dc	Telecom approved for China	4 to 20 mA analog and 1 NPN/PNP discrete
Q240RA-CN-ULO					0 to 10 V analog and 1 NPN/PNP discrete
Q240RA-EU-ILO				Telecom approved for Europe, UK, Australia, and New Zealand	4 to 20 mA analog and 1 NPN/PNP discrete
Q240RA-EU-ULO					0 to 10 V analog and 1 NPN/PNP discrete
Q240RA-US-ILO				Telecom approved for US and Canada	4 to 20 mA analog and 1 NPN/PNP discrete
Q240RA-US-ULO					0 to 10 V analog and 1 NPN/PNP discrete

## Overview

The R-GAGE sensor emits a well-defined beam of high-frequency radio waves from an internal antenna. Some of this emitted energy is reflected back to the receiving antenna. Signal processing electronics determine the distance from the sensor to the object based on the time delay of the return signal.

The analog output is scaled over the entire sensing range. The discrete output is pre-set to default distances at the factory and can be reconfigured for different distances using the DIP switches on the side of the sensor. The sensor is plug-in ready for immediate operation.

The sensitivity is precalibrated at the factory, assuming that the sensing field will be clear of obstacles. The sensitivity can be adjusted using the DIP switches on the side of the sensor.



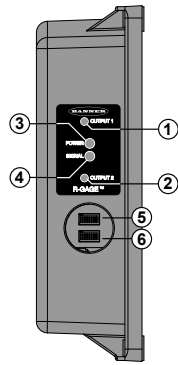

Figure 1. R-GAGE features

1. Output LEDs: Yellow (measuring a target inside the measuring range); Red (configuration)
2. Output LEDs: Yellow (output 2 energized); Red (configuration)
3. Power LED: Green (power ON)
4. Signal Strength LED: Red (flashes in proportion to the signal strength)
5. DIP switch row A
6. DIP switch row B

Access the DIP switches behind the threaded cap on the sensor side.

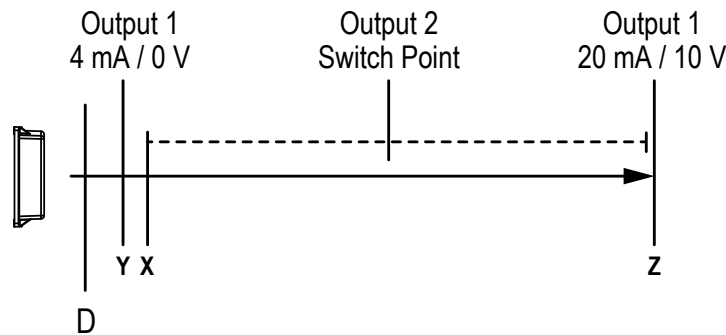
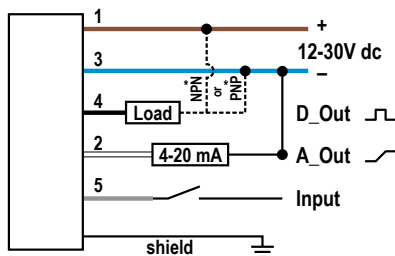

Figure 2. R-GAGE setpoint distances

		Distance
X	Minimum discrete output setpoint distance	4 m (13.1 ft)
Y	Start of analog span	3.5 m (11.5 ft)
Z	End of analog span/maximum discrete output setpoint distance	100 m (328 ft)
D	Dead Zone <sup>1</sup>	

## Wiring

### Analog Current Model



\* User-configurable PNP/NPN setting

### Analog Voltage Model

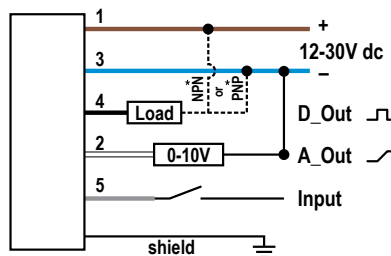

\* User-configurable PNP/NPN setting

### Wiring Key:

1. Brown
2. White
3. Blue
4. Black
5. Gray (Do not connect)



Note: Banner recommends that the shield wire (QD cordsets only) be connected to earth ground or dc common. Shielded cordsets are recommended for all QD models.

<sup>1</sup> Typical dead zone: 0.4 m (1.3 ft) for moving and 1.0 m (3.3 ft) for stationary targets, but varies with target reflectivity.

## Sensor Configuration

The sensitivity and output configuration can be selected via the DIP switches on the side of the sensor. Use the included spanner to open the screw-off cover on the side of the sensor and access the DIP switches.



**Important:** Tighten the DIP switch cover a full quarter turn after contact to maintain the watertight seal.

## DIP Switch Functions

Switches	Function
A1, A2, A3, A4	Discrete Output switching distance (detects objects from sensor face to this point)
A5, A6, A7	Analog Response Speed
A8	Polarity
B1, B2, B3	Sensitivity (higher sensitivity sees weaker objects and has a larger beam pattern)
B4, B5, B6	Discrete Response Speed
B7	Normally Open/Normally Closed output functionality
B8	Analog Slope

DIP switch 1 is on the left and DIP switch 8 is on the right.

## Distance Settings

Zone Distance				
A1	A2	A3	A4	Distance
0	0	0	0	4 m (13.1 ft)
0	0	0	1	5 m (16.4 ft)
0	0	1	0	10 m (32.8 ft)
0	0	1	1	15 m (49.2 ft)
0*	1*	0*	0*	20 m (65.6 ft)
0	1	0	1	25 m (82.0 ft)
0	1	1	0	30 m (98.4 ft)
0	1	1	1	35 m (114.8 ft)
1	0	0	0	40 m (131.2 ft)
1	0	0	1	45 m (147.6 ft)
1	0	1	0	50 m (164.0 ft)
1	0	1	1	60 m (196.9 ft)
1	1	0	0	70 m (229.7 ft)
1	1	0	1	80 m (262.5 ft)
1	1	1	0	90 m (295.3 ft)
1	1	1	1	100 m (328.1)

\* Default settings



Note: Highest sensitivity is achieved only if the sensing distance is 72 m (236.2 ft) or less.

## Analog Speeds

A5	A6	A7	Response Speed (ms)	Loss of Signal (ms)
0	0	0	100	250
0	0	1	250	500
0	1	0	350	1000
0	1	1	650	2000
1*	0*	0*	1250	3000
1	0	1	2500	4000
1	1	0	5000	5000
1	1	1	10000	6000

\* Default settings

## Sensitivity Selection

B1	B2	B3	Sensitivity
0	0	0	8 (Highest)
0	0	1	7...
0	1	0	6 (High)
0	1	1	5...
1*	0*	0*	4 (Medium)
1	0	1	3...
1	1	0	2 (Low)
1	1	1	1 (Lowest)

\* Default settings

## Output Configuration

A8	NPN / PNP	B7	Normally Open / Closed
0*	NPN	0*	NO
1	PNP	1	NC

\* Default settings

## Discrete Response Speed

B4	B5	B6	ON Total (ms)	OFF Total (ms)	Total (ms)
0	0	0	15	15	30
0	0	1	30	70	100
0	1	0	30	120	150
0*	1*	1*	50	300	350
1	0	0	50	600	650
1	0	1	30	1000	1030
1	1	0	120	600	720
1	1	1	120	6000	6120

\* Default settings

## Analog Slope

B8	Positive/Negative
0*	Positive
1	Negative

\*Default settings

## Specifications

**Supply Voltage (Vcc)**  
12 V dc to 30 V dc

**Power and Current Consumption**, exclusive of load  
Normal Run Mode: 2.1 W, Current consumption < 85 mA at 24 V dc

**Range**  
The sensor is able to detect a proper object (see Detectable Objects) from 1 m to 100 m (3.3 ft to 328 ft), depending on target

**Detectable Objects**  
Objects containing metal, water, or similar high-dielectric materials

**Operating Principle**  
Frequency modulated continuous-wave (FMCW) radar

**Operating Frequency**  
24.075–24.175 GHz, ISM Band

**Maximum Output Power**  
US, CN Models: ERP: 3.3 mW, 5 dBm, EIRP: 358 mW, 25.5 dBm  
EU Models: ERP: 0.9 mW, -0.5 dBm, EIRP: 100 mW, 20 dBm

**Supply Protection Circuitry**  
Protected against reverse polarity and transient overvoltages

**Delay at Power-up**  
Less than 2 seconds

**Output Configuration**  
Analog output: 4 mA to 20 mA or 0 V to 10 V, depending on model  
Discrete output: NPN/PNP and N.O./N.C. are user-configurable; 150 mA maximum load

**Output Protection**  
Protected against short circuit conditions

**Response Time**  
DIP-switch-configurable ON/OFF response time

**Vibration and Mechanical Shock**  
Vibration 10 Hz to 55 Hz 0.5 mm p-p amplitude per IEC 60068-2-6  
Shock 30G 11 ms duration, half sine wave per IEC 60068-2-27

**Temperature Affect**  
0.05 m/°C, typical

**Analog Linearity**  
±1 m

**Analog Resolution**  
0.5 m

Analog current output (Q240RA...I models):  
1 kΩ maximum at 24 V; maximum load resistance =  $[(V_{cc}-4.5)/0.02 \Omega]$

Analog voltage output (Q240RA...U models):  
2.5 kΩ min. load resistance

**Indicators**  
Power LED: Green (power ON)  
Signal Strength LED: Red, flashes in proportion to signal strength. Steady on at 4x excess gain. Only indicates signal amplitude, not target distance.  
Output LEDs: Yellow (output energized) / Red (configuration)  
See [Overview](#) on page 1

**Adjustments**  
DIP-switch-configurable sensing distance, sensitivity, response time, and output configuration

**Construction**  
Housing: Polycarbonate  
Lightpipes: Acrylic  
Access Cap: Polyester

**Operating Temperature**  
-40 °C to +65 °C (-40 °F to +149 °F)

**Environmental Rating**  
IEC IP67

**Connections**  
Integral M12 Euro-style QD fitting. QD models require a mating cordset

### Certifications



, CMIIT Category G, FCC part 15, RSS-210, ETSI/EN 300

440; others pending

Beam Angles

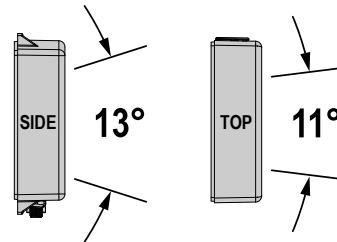

FCC ID: UE3Q240RAUS—This device complies with Part 15 of the FCC Rules. Operation is subject to the following two conditions: (1) this device may not cause harmful interference, and (2) this device must accept any interference received, including interference that may cause undesired operation.

## Industry Canada

IC: 7044A-Q240RA—This device complies with Industry Canada license-exempt RSS standard(s). Operation is subject to the following two conditions: (1) this device may not cause interference, and (2) this device must accept any interference, including interference that may cause undesired operation of the device.

Cet appareil est conforme aux CNR exempts de licence d'Industrie Canada. Son fonctionnement est soumis aux deux conditions suivantes: (1) Ce dispositif ne peut causer des interférences; et (2) Ce dispositif doit accepter toute interférence, y compris les interférences qui peuvent entraîner un mauvais fonctionnement de l'appareil.

NCC

警語低功率電波輻射性電機管理辦法第十二條經型式認證合格之低功率射頻電機，非經許可，公司、商號或使用者均不得擅自變更頻率、加大功率或變更原設計之特性及功能。第十四條低功率射頻電機之使用不得影響飛航安全及干擾合法通信；經發現有干擾現象時，應立即停用，並改善至無干擾時方得繼續使用。前項合法通信，指依電信規定作業之無線電信。低功率射頻電機須忍受合法通信或工業、科學及醫療用電波輻射性電機設備之干擾

在 5.25-5.35 赫茲頻帶操作之無線資訊傳輸設備，限於室內使用。

Beam Pattern—US and CN Models

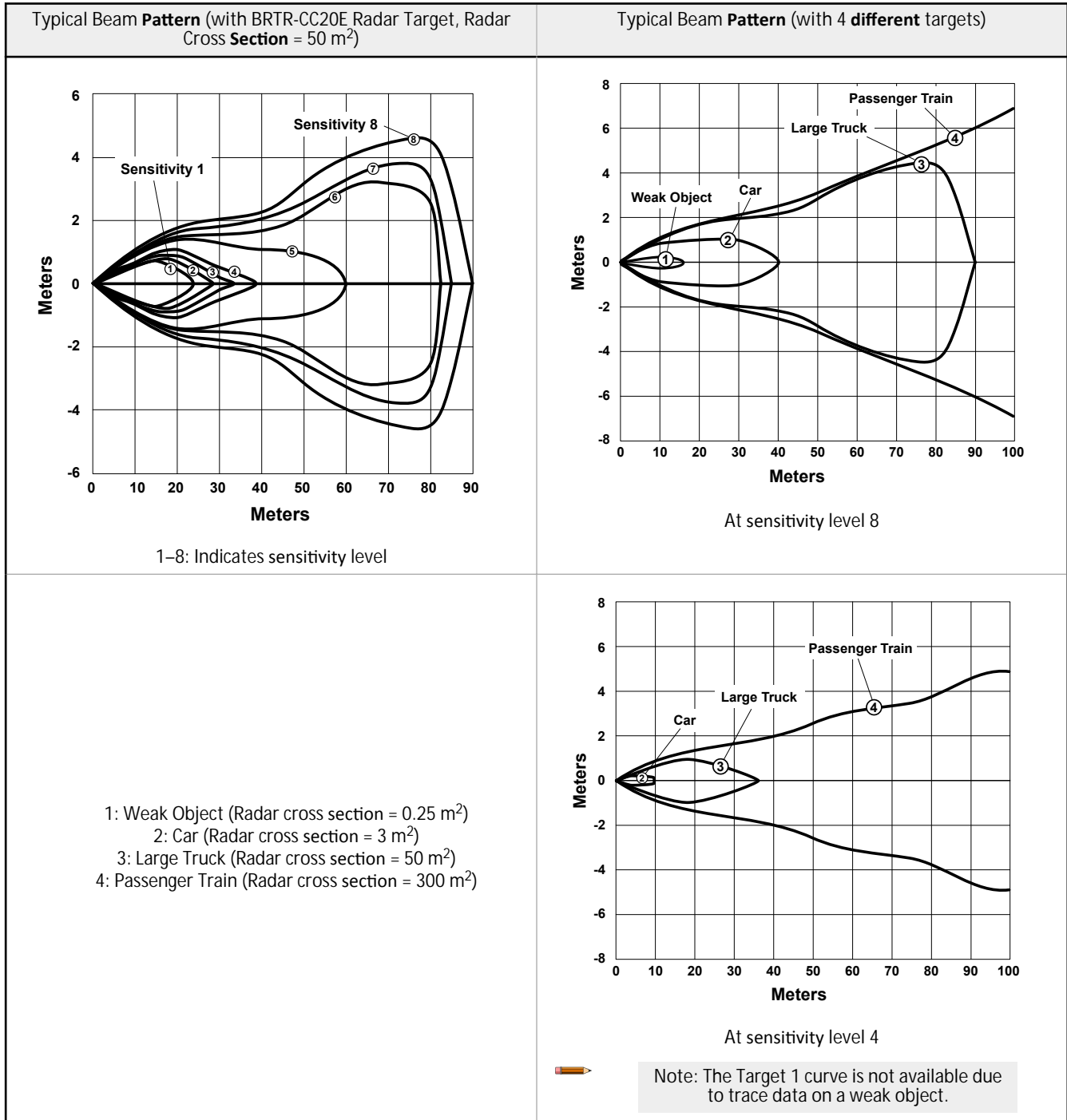

### Beam Pattern—EU Models

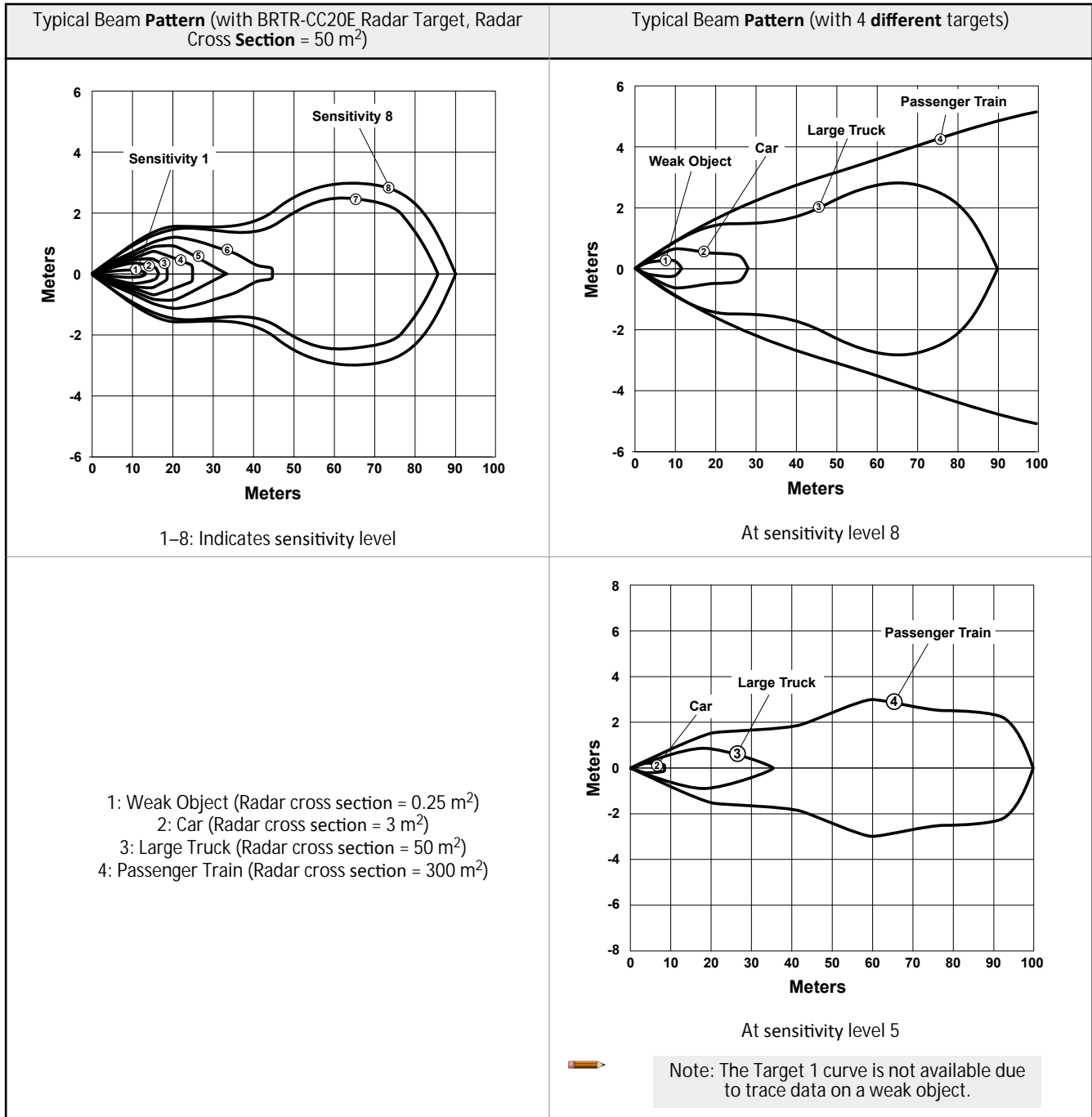

## Dimensions

All measurements are listed in millimeters [inches], unless noted otherwise.

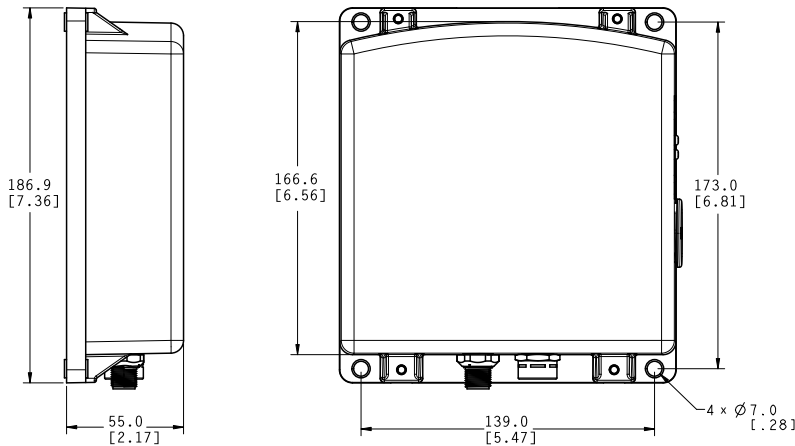

## Windows

The R-GAGE sensor can be placed behind a glass or a plastic window, but the configuration must be tested and the distance from the sensor to the window must be determined and controlled prior to installation. There is typically a 20% signal reduction when the sensor is placed behind a window.

Polycarbonate at 4 mm thickness performs well in most situations, but the performance depends on filler materials. Thinner (1 to 3 mm) windows have high reflection. The amount of reflection depends on the material, thickness, and distance from the sensor to the window.

Locate the sensor in a position of minimum reflection from the window, which will repeat every 6.1 mm of distance between the sensor and the window. The positions of maximum reflection from the window repeat between the minimums, and decrease in effect until the window is approximately 150 mm (5.9 in) away. Consult the factory for pre-tested window materials which can be used at any distance without issue.

Additionally, the face of the window should be protected from flowing water and ice by use of a flow diverter or hood directly above the window. Falling rain or snow in the air in front of the window, light water mist, or small beads on the face of the window are typically not an issue. However, a thick, continuous surface of water or ice directly on the face of the window can be detected as a dielectric boundary.

The Q240WS is a clip-on hydrophobic weather shield accessory specially designed to meet these requirements. This is recommended for outdoor use, especially where snow or rain is likely to accumulate on the front surface of the sensor.

## Accessories

### Quick Disconnect (QD) Cordsets

5-Pin Threaded M12/Euro-Style Cordsets—with Shield				
Model	Length	Style	Dimensions	Pinout (Female)
MQDEC2-506	1.83 m (6 ft)	Straight		<p>1 = Brown 2 = White 3 = Blue 4 = Black 5 = Gray</p>
MQDEC2-515	4.57 m (15 ft)			
MQDEC2-530	9.14 m (30 ft)			
MQDEC2-550	15.2 m (50 ft)			
MQDEC2-506RA	1.83 m (6 ft)	Right-Angle		
MQDEC2-515RA	4.57 m (15 ft)			
MQDEC2-530RA	9.14 m (30 ft)			
MQDEC2-550RA	15.2 m (50 ft)			





Note: Pin 5 is not used.

## Brackets and Other Accessories

### SMBQ240SS2

- Add-on accessory to be used in conjunction with SMBQ240SS1
- Provides  $\pm 20^\circ$  of tilt in second axis for maximum control of sensor alignment
- 12 gauge stainless steel

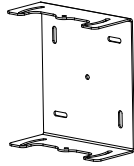

### Q240WS

- Coated to help repel water and maximize signal strength
- Snap-on cover for easy application and replacement

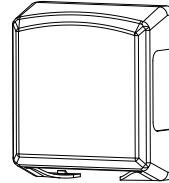

### SMBQ240SS1

- Sensor mounting plate and pivoting bracket
- Provides  $\pm 20^\circ$  of tilt in one axis for enhanced sensor alignment
- 12 gauge stainless steel
- Sensor can mount on bracket horizontally or vertically

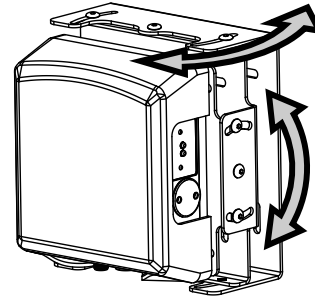
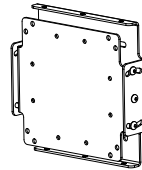

Q240RA R-GAGE sensor shown with all three accessories installed.

## Banner Engineering Corp. Limited Warranty

Banner Engineering Corp. warrants its products to be free from defects in material and workmanship for one year following the date of shipment. Banner Engineering Corp. will repair or replace, free of charge, any product of its manufacture which, at the time it is returned to the factory, is found to have been defective during the warranty period. This warranty does not cover damage or liability for misuse, abuse, or the improper application or installation of the Banner product.

THIS LIMITED WARRANTY IS EXCLUSIVE AND IN LIEU OF ALL OTHER WARRANTIES WHETHER EXPRESS OR IMPLIED (INCLUDING, WITHOUT LIMITATION, ANY WARRANTY OF MERCHANTABILITY OR FITNESS FOR A PARTICULAR PURPOSE), AND WHETHER ARISING UNDER COURSE OF PERFORMANCE, COURSE OF DEALING OR TRADE USAGE.

This Warranty is exclusive and limited to repair or, at the discretion of Banner Engineering Corp., replacement. IN NO EVENT SHALL BANNER ENGINEERING CORP. BE LIABLE TO BUYER OR ANY OTHER PERSON OR ENTITY FOR ANY EXTRA COSTS, EXPENSES, LOSSES, LOSS OF PROFITS, OR ANY INCIDENTAL, CONSEQUENTIAL OR SPECIAL DAMAGES RESULTING FROM ANY PRODUCT DEFECT OR FROM THE USE OR INABILITY TO USE THE PRODUCT, WHETHER ARISING IN CONTRACT OR WARRANTY, STATUTE, TORT, STRICT LIABILITY, NEGLIGENCE, OR OTHERWISE.

Banner Engineering Corp. reserves the right to change, modify or improve the design of the product without assuming any obligations or liabilities relating to any product previously manufactured by Banner Engineering Corp. Any misuse, abuse, or improper application or installation of this product or use of the product for personal protection applications when the product is identified as not intended for such purposes will void the product warranty. Any modifications to this product without prior express approval by Banner Engineering Corp will void the product warranties. All specifications published in this document are subject to change. Banner reserves the right to modify product specifications or update documentation at any time. Specifications and product information in English supersede that which is provided in any other language. For the most recent version of any documentation, refer to:

[www.bannerengineering.com](http://www.bannerengineering.com).