

Output and measuring range setting

The measuring range and the output signal can be adapted to the relevant application requirements via programming inputs. In teach-in mode with inversion or reset function.

Measuring range adjustment via programming inputs L_a and L_b

1. Place magnet in new start position.

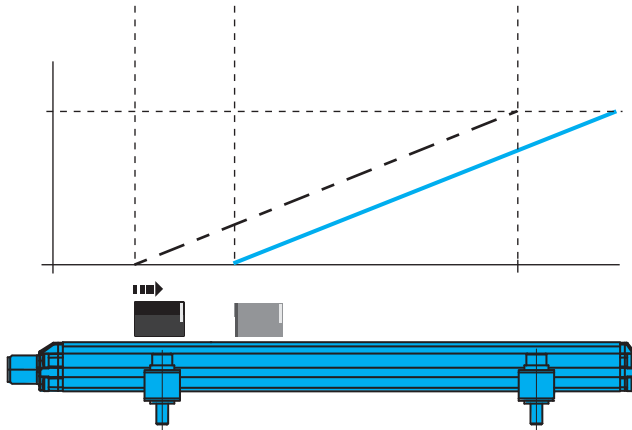

Adopting a new start position

2. Place magnet at new end position.

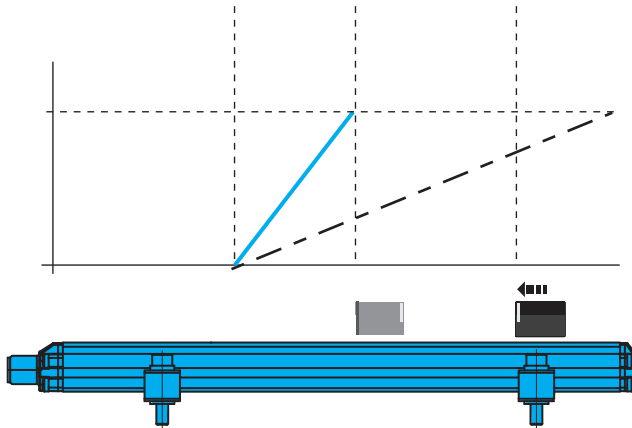

Adopting a new end position

3. The new measuring range

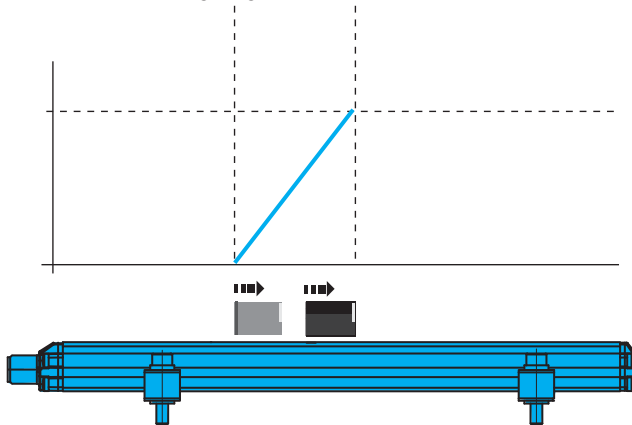

Series		
Output signal		
Transducer interface		
Input interface		
Part number		
Output voltage*		
Output current*		
Load current		
max. ripple		
Load resistance (recommended)		
System resolution		
Sampling rate		
max. non-linearity		
Temperature coefficient		
Operating voltage		
Current consumption		
Operating temperature		
Storage temperature range		
Pin assignments	Pin	Color
Output signals	1	YE
	2	GY
	3	PK
	4	RD
	5	GN
	8	WH
Operating voltage	6	BU
	7	BN

■ Please enter the code for the output signal and the nominal stroke in the ordering code!

Preferred models interface A500 and E500

BTL6-A500-M____-PF-S115

BTL6-E500-M____-PF-S115

are available from stock in the nominal lengths highlighted in blue.

■ Included:

- Transducer
- Mounting clamps with isolation washers and screws
- Short user's guide

Please order separately:

Magnets from page 52

Connectors, page 156

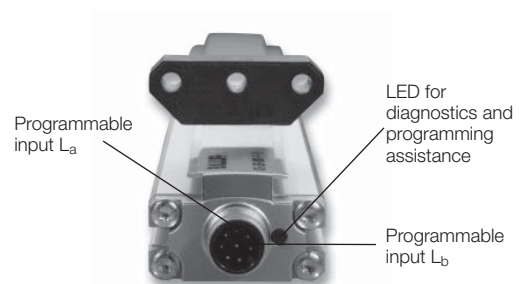

Profile Series PF

Analog interface

BTL6 profile PF	BTL6 profile PF	BTL6 profile PF	BTL6 profile PF
analog	analog	analog	analog
A	E	C	G
analog	analog	analog	analog
BTL6- A 500-M_...-PF-S115	BTL6- E 500-M_...-PF-S115	BTL6- C 500-M_...-PF-S115	BTL6- G 500-M_...-PF-S115
0...10 V	4...20 mA	0.1...20 mA	-10...10 V
max. 5 mA			max. 5 mA
≤ 5 mV			≤ 5 mV
≤ 0.35 mV	≤ 500 ohms (500 ohms)	≤ 500 ohms (500 ohms)	≤ 0.35 mV
$f_{max} = 2$ kHz	≤ 0.7 μ A	≤ 0.7 μ A	$f_{max} = 2$ kHz
±200 μ m up to 500 mm nominal stroke	$f_{max} = 2$ kHz	$f_{max} = 2$ kHz	±200 μ m up to 500 mm nominal stroke
±0.04 % 500... max. nominal stroke	±200 μ m up to 500 mm nominal stroke	±200 μ m up to 500 mm nominal stroke	±0.04 % 500... max. nominal stroke
30 ppm at 500 mm	±0.04 % 500... max. nominal stroke	±0.04 % 500... max. nominal stroke	30 ppm at 500 mm
10...30 V DC	30 ppm at 500 mm	30 ppm at 500 mm	10...30 V DC
≤ 150 mA	10...30 V DC	10...30 V DC	≤ 150 mA
-25...+70 °C	≤ 150 mA	≤ 150 mA	-25...+70 °C
-40...+100 °C	-25...+70 °C	-25...+70 °C	-40...+100 °C
BTL6- A 500...	-40...+100 °C	-40...+100 °C	BTL6- G 500...
0 V	BTL6- E 500...	BTL6- C 500...	0 V
0 V Output	0 V	0 V	0 V Output
	0 V Output	0 V Output	
L_a (programming input)	L_a (programming input)	L_a (programming input)	L_a (programming input)
0...10 V	4...20 mA	0.1...20 mA	-10...10 V
L_b (programming input)	L_b (programming input)	L_b (programming input)	L_b (programming input)
GND	GND	GND	GND
10...30 V	10...30 V	10...30 V	10...30 V

P
General data
Analog interface
Digital pulse interface
SSI interface
CANopen interface
DeviceNet interface
PROFIBUS-DP interface
Magnets floating
Magnets captive, control arm

PF
General data
Analog interface
Magnets floating
Magnets captive, control arm

AT
General data
Analog interface
Modes
Digital pulse interface
VARAN bus interface
Accessories

BIW
General data
Analog interface

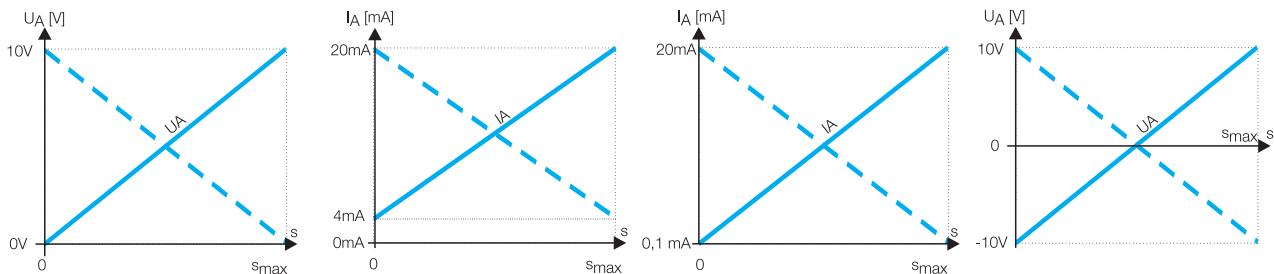

* Output signal can be inverted via programming inputs.

Ordering example:

BTL6-500-M_...-PF-S115



Output signal	Standard nominal stroke [mm]
A 0...10 V	0050, 0100, 0130, 0150, 0175, 0200,
E 4...20 mA	0225, 0250, 0300, 0350, 0360, 0400,
C 0.1...20 mA	0450, 0500, 0550, 0600, 0650, 0700,
G -10...10 V	0750, 0800, 0850, 0900, 0950, 1000,
	1100, 1200, 1250, 1300, 1400, 1500,
	1600, 1700, 1750, 1800, 1900, 2000,
	2250, 2500, 2750, 3000, 3250, 3500,
	3550, 3750, 4000, 4250, 4572