

GRSE18(S)V

Cylindrical photoelectric sensors

en, de, fr, pt, it, es, zh, ja, ru

SICK
Sensor Intelligence.



GRSE18(S)V

Cylindrical photoelectric sensors



de
en
es
fr
it
ja
pt
ru
zh

Described product

GR18 Inox
GRSE18(S)V

Manufacturer

SICK AG
Erwin-Sick-Str. 1
79183 Waldkirch
Germany

Production location

SICK, Malaysia

Legal information

This work is protected by copyright. Any rights derived from the copyright shall be reserved for SICK AG. Reproduction of this document or parts of this document is only permissible within the limits of the legal determination of Copyright Law. Any modification, abridgment or translation of this document is prohibited without the express written permission of SICK AG.

The trademarks stated in this document are the property of their respective owner.

© SICK AG. All rights reserved.

Original document

This document is an original document of SICK AG.



Contents

1	Safety notes.....	5
2	Intended use.....	5
3	Operating and status indicators.....	5
4	Mounting.....	6
5	Electrical installation.....	7
6	Commissioning.....	10
7	Troubleshooting.....	11
	7.1 Troubleshooting table.....	11
8	Disassembly and disposal.....	12
9	Maintenance.....	12
10	Technical specifications.....	13

1 Safety notes

- Read the operating instructions before commissioning.
-  Connection, mounting, and setting may only be performed by skilled person.
- Not a safety component in accordance with the EU Machinery Directive.
- Power supply: Class 2
Enclosure type 1
- When commissioning, protect the device from moisture and contamination.
- These operating instructions contain information required during the life cycle of the sensor.

2 Intended use

The GRSE18(S)V is an opto-electronic through-beam photoelectric sensor (referred to as “sensor” in the following) for the optical, non-contact detection of objects, animals, and persons. A sender (WS) and a receiver (WE) are required for operation. If the product is used for any other purpose or modified in any way, any warranty claim against SICK AG shall become void.

3 Operating and status indicators

Table 1: Dimensional drawings

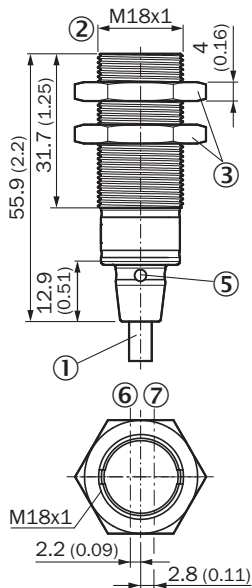

Figure 1: Short variant, connecting cable

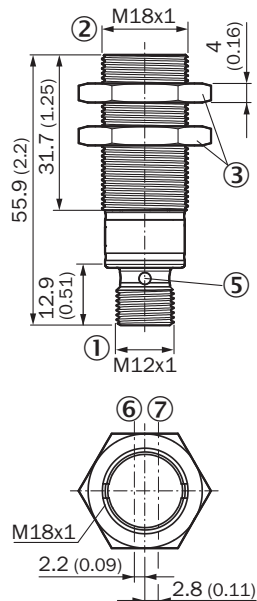

Figure 2: Short variant, M12 male connector

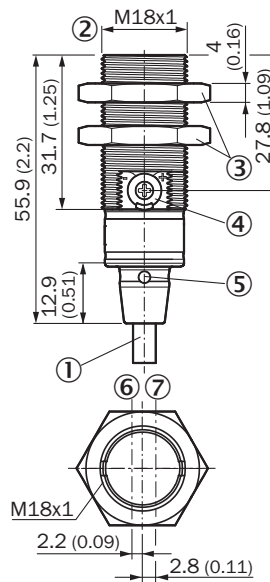

Figure 3: Short variant, potentiometer, connecting cable

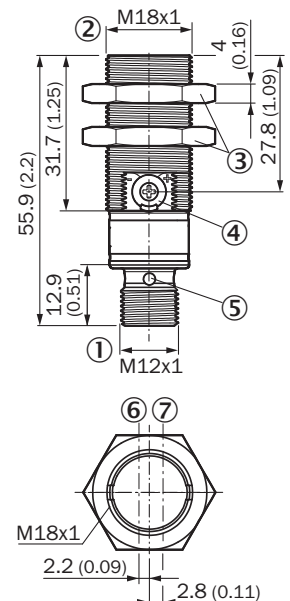

Figure 4: Short variant, potentiometer, M12 male connector

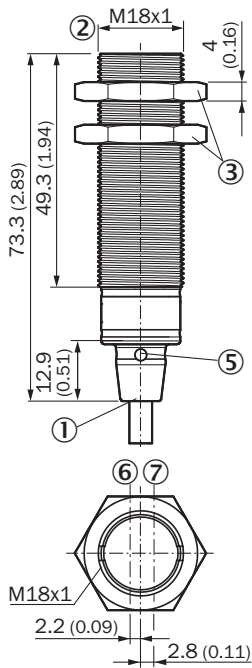

Figure 5: Long variant, connecting cable

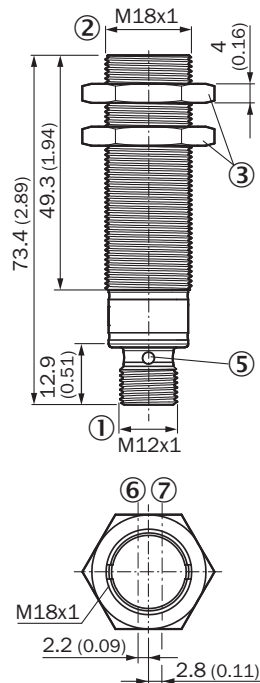

Figure 6: Long variant, M12 male connector

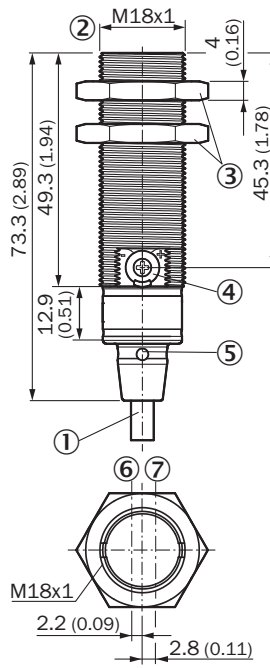

Figure 7: Long variant, potentiometer, connecting cable

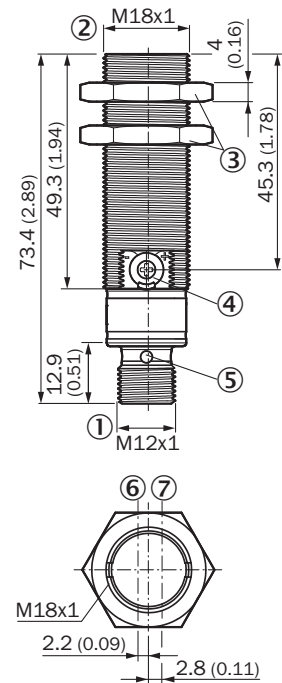

Figure 8: Long variant, potentiometer, M12 male connector

- ① Connection
- ② Mounting bracket M18 x 1
- ③ Fastening nuts (2 x); WS24, stainless steel
- ④ Potentiometer, 270°
- ⑤ LED indicator (4 x)
- ⑥ Optical axis, receiver
- ⑦ Optical axis, sender

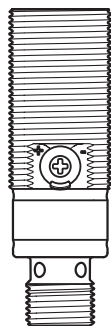
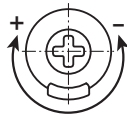
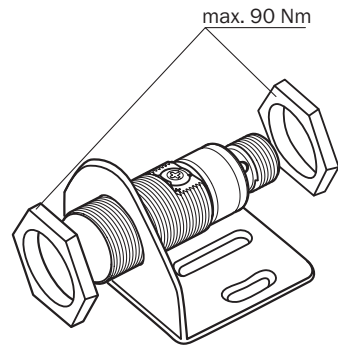

Figure 9: Operating element: sensitivity setting

4 Mounting

Mount sensors (sender and receiver) using suitable mounting brackets (see the SICK range of accessories). Align the sender and receiver with each other.



Note the sensor's maximum permissible tightening torque of 90 Nm.



NOTE

Swap the sender and receiver arrangement at every second photoelectric through-beam sensor and ensure that there is sufficient distance between the through-beam photoelectric sensors.

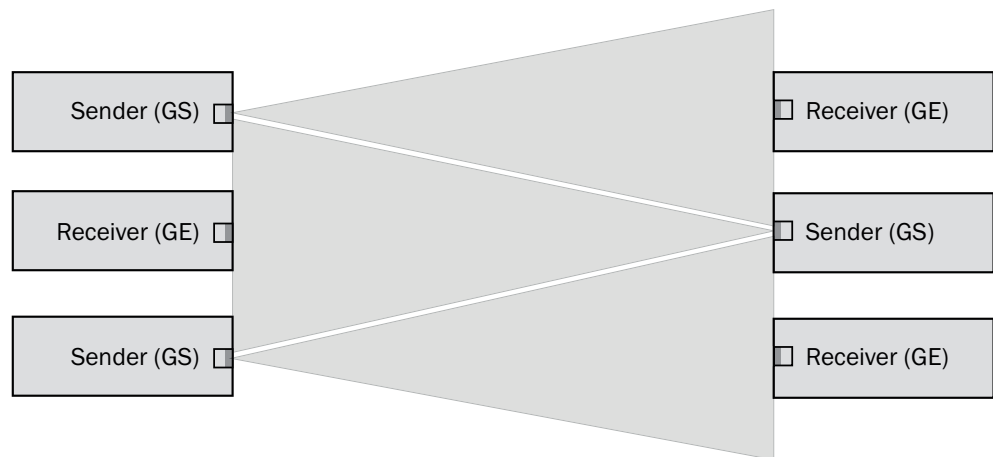

Figure 10: Arrangement of several through-beam photoelectric sensors

5 Electrical installation

The sensors must be connected in a voltage-free state ($U_V = 0\text{ V}$). The following information must be observed, depending on the connection type:

- Male connector connection: pin assignment
- Cable: wire color

Only apply voltage/switch on the voltage supply ($U_V > 0\text{ V}$) once all electrical connections have been established. The green LED indicator lights up on the sensor.

Explanations of the connection diagram (Tables 2 and 3):

Q / \bar{Q} = switching outputs

TI / Test = test input (see table 5)

n. c. = not connected

DC: 10... 30 V DC, see „Technical specifications“, page 13

Table 2: DC, GRS



GRS18(S)V	D11xxx	D13x2/4x	D13x1/3x	D24xxx	D23xd/4x	D23x1/3x
1	+ (L+)	+ (L+)	+ (L+)	+ (L+)	+ (L+)	+ (L+)
2	n. c.	n. c.	n. c.	n. c.	n. c.	n. c.
3	- (M)	- (M)	- (M)	- (M)	- (M)	- (M)
4	Test	Test	n. c.	Q	Test	n. c.
	 1 = brn 2 = wht 3 = blu 4 = blk 0.14 mm ² AWG26	 1 = brn 2 = wht 3 = blu 4 = blk 0.14 mm ² AWG26				

Table 3: DC, GRE

GRE18(S)V	x11xxx	x13xxx	x24xxx	x23xxx
1	+ (L+)	+ (L+)	+ (L+)	+ (L+)
2	\bar{Q}	n. c.	\bar{Q}	n. c.
3	- (M)	- (M)	- (M)	- (M)
4	Q	Q	Q	Q
	 1 = brn 2 = wht 3 = blu 4 = blk 0.14 ... 1.5 mm ² AWG26	 1 = brn - 3 = blu 4 = blk 0.14 ... 1.5 mm ² AWG26		

Table 4: DC

PNP: Q (≤ 100 mA)		
NPN: Q (≤ 100 mA)		
PNP: \bar{Q} (≤ 100 mA)		
NPN: \bar{Q} (≤ 100 mA)		

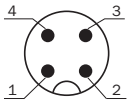
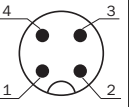
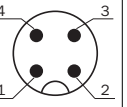
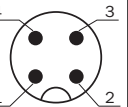
Table 5: Test

	Test

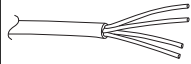
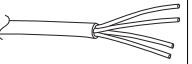
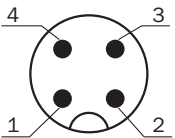
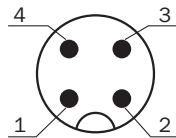
6 Commissioning

1 Alignment

Align the sender with the receiver. Select the position so that the red emitted light beam hits the receiver. Tip: Use white paper or a reflector as an alignment aid. The sender must have a clear view of the receiver, with no object in the path of the beam [see figure]. You must ensure that the optical openings (front screen) of the sensors are completely clear. Align the sender with the receiver. Select the position so that the infrared light (not visible) hits the receiver. The correct alignment can only be detected via the LED indicators. See figure and table 4. The sender must have a clear view of the receiver, with no object in the path of the beam. You must ensure that the optical openings (front screen) of the sensors are completely clear.

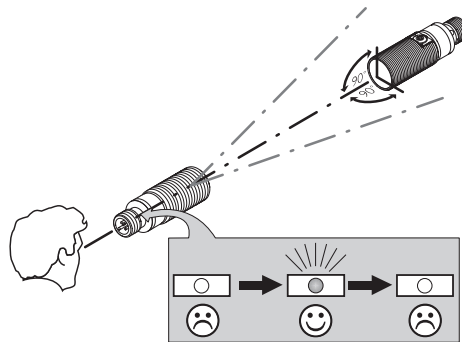

Figure: Alignment

2 Sensing range

Observe the application conditions: Adjust the distance between the sender and the receiver according to the corresponding diagram [see figure 0] (x = sensing range, y = operating reserve).

If several through-beam photoelectric sensors which are installed next to one another are to be used, we recommend swapping the sender/receiver arrangement at every second through-beam photoelectric sensor and ensuring that there is sufficient distance between the through-beam photoelectric sensors. By doing this, mutual interference can be prevented [see figure 10].

Operating reserve

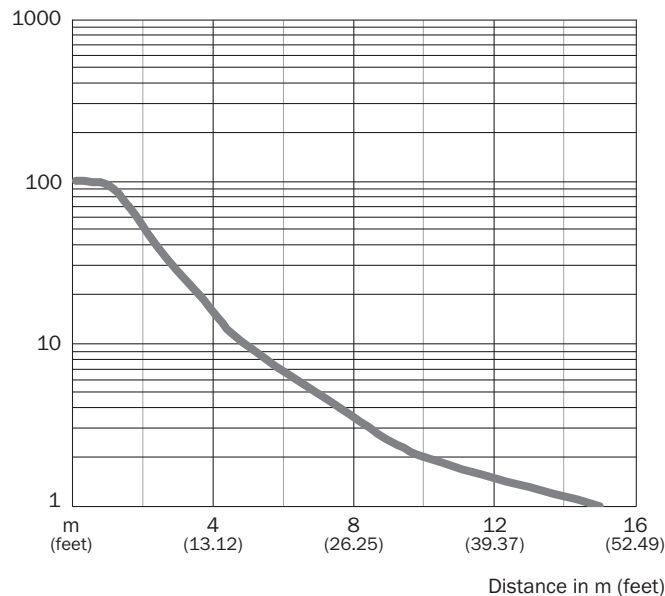

Use and Table 3 to check the function. If the switching output fails to behave in accordance with Table 3, check the application conditions. See section Fault diagnosis.

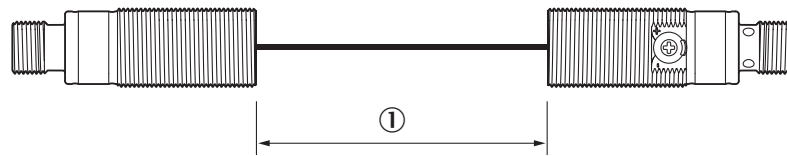

Figure 11: sensing range areas

Table 6: Definition of sensing range

	GRSE18(S)V
①	0 ... 15 m

① Sensing range

3 Sensitivity setting

Sensor which it is not possible to set: The sensor is adjusted and ready for operation. The sensitivity is adjusted with the potentiometer (type: 270°). Clockwise rotation: operating reserve increased; counterclockwise rotation: operating reserve reduced. We recommend setting the potentiometer to “Maximum”. The sensor is adjusted and ready for operation.

4 Test input

Test input: The GRSE18(S)V sensors feature a test input (“TI” or “Test” on the connection diagram [table 2]), which can be used to switch the sender off and, therefore, check that the sensor is functioning correctly: If female cable connectors with LED indicators are used, you must ensure that the TI is assigned accordingly.

There must be no object between the sender and receiver; activate the test input (see the connection diagram [table 2], TI at 0 V). The send LED is shut down or the detection of an object is simulated. Use the following table to check the function. If the switching output fails to behave in accordance with the following table, check the application conditions. See section Fault diagnosis.

7 Troubleshooting

The Troubleshooting table indicates which measures are to be taken if the sensor stops working.

7.1 Troubleshooting table

Table 7: Troubleshooting

LED indicator/fault pattern	Cause	Measures
Green LED does not light up	No voltage or voltage below the limit values	Check the power supply, check all electrical connections (cables and plug connections)
Green LED does not light up	Voltage interruptions	Ensure there is a stable power supply without interruptions
Green LED does not light up	Sensor is faulty	If the power supply is OK, replace the sensor
Green LED lights up, no output signal when object is detected	Test input (Test) is not connected properly	See the note on connecting the TI
Yellow LED flashes	Sensor is still ready for operation, but the operating conditions are not ideal	Check the operating conditions: Fully align the beam of light (light spot) with the receiver / Clean the optical surfaces / Readjust the sensitivity (potentiometer) / If the potentiometer is set to the max. sensitivity: Reduce the

LED indicator/fault pattern	Cause	Measures
		distance between the sender and the receiver/ Check sensing range and adjust if necessary, see table 6 .
Yellow LED lights up, no object in the path of the beam	The beam of light of a photoelectric through-beam sensor hits the receiver of another (neighboring) photoelectric through-beam sensor	Swap the sender and receiver arrangement at every second through-beam photoelectric sensor and ensure that there is sufficient distance between the through-beam photoelectric sensors, see figure 10 .

8 Disassembly and disposal

The sensor must be disposed of according to the applicable country-specific regulations. Efforts should be made during the disposal process to recycle the constituent materials (particularly precious metals).

9 Maintenance

SICK sensors are maintenance-free.

We recommend doing the following regularly:

- Clean the external lens surfaces
- Check the screw connections and plug-in connections

No modifications may be made to devices.

Subject to change without notice. Specified product properties and technical data are not written guarantees.

10 Technical specifications

	GRSE18(S)-xxx2xV, Infraredlight	GRSE18(S)-xxx4xV, visible red light
Sensing range	0 ... 10 m	0 ... 10 m
Sensing range max.	0 ... 15 m	0 ... 15 m
Light spot diameter/distance	420 mm / 10 m	250 mm / 10 m
Supply voltage V_S	DC 10 ... 30 V ²	DC 10 ... 30 V ²
Output current I_{max}	100 mA	100 mA
Max. switching frequency	1,000 / s ⁵	1,000 / s ⁵
Max. response time	< 0,5 ms ⁶	< 0,5 ms ⁶
Enclosure rating	IP67,IP68,IP69K ¹¹	IP67,IP68,IP69K ¹¹
Protection class	III ⁸	III ⁸
Circuit protection	A,B,D ¹⁰	A,B,D ¹⁰
Ambient operating temperature	-25 °C ... +55 °C	-25 °C ... +55 °C

- 1 Tastgut mit 90 % Remission (bezogen auf Standard-Weiß DIN 5033)
 2 Grenzwerte; Betrieb im kurzschlussgeschützten Netz max. 8 A; Restwelligkeit max. 5 V_{ss}
 4 Gebrauchskategorie: AC-15, DC-13 (EN 60947-1)
 5 Mit Hell- / Dunkelverhältnis 1:1
 6 Signallaufzeit bei ohmscher Last
 7 gültig für Q\ auf Pin2, wenn per Software konfiguriert
 8 Bemessungsspannung DC 50 V
 10 A = U_V-Anschlüsse verpolsicher
 B = Ein- und Ausgänge verpolsicher
 D = Ausgänge überstrom- und kurzschlussfest
 11 IP68: according to EN 60529 (water depth of 10 m / 24 h).
 IP69K: according to ISO 20653:2013-03.

GRSE18(S)V

Rundlichtschranken



de
en
es
fr
it
ja
pt
ru
zh

Beschriebenes Produkt

GR18 Inox
GRSE18(S)V

Hersteller

SICK AG
Erwin-Sick-Str. 1
79183 Waldkirch
Deutschland

Fertigungsstandort

SICK, Malaysia

Rechtliche Hinweise

Dieses Werk ist urheberrechtlich geschützt. Die dadurch begründeten Rechte bleiben bei der Firma SICK AG. Die Vervielfältigung des Werks oder von Teilen dieses Werks ist nur in den Grenzen der gesetzlichen Bestimmungen des Urheberrechtsgesetzes zulässig. Jede Änderung, Kürzung oder Übersetzung des Werks ohne ausdrückliche schriftliche Zustimmung der Firma SICK AG ist untersagt.

Die in diesem Dokument genannten Marken sind Eigentum ihrer jeweiligen Inhaber.

© SICK AG. Alle Rechte vorbehalten.

Originaldokument

Dieses Dokument ist ein Originaldokument der SICK AG.



Inhalt

11	Sicherheitshinweise.....	17
12	Bestimmungsgemäße Verwendung.....	17
13	Bedien- und Anzeigeelemente.....	17
14	Montage.....	18
15	Elektronische Installation.....	19
16	Inbetriebnahme.....	22
17	Störungsbehebung.....	23
	17.1 Tabelle Störungsbehebung.....	23
18	Demontage und Entsorgung.....	24
19	Wartung.....	24
20	Technische Daten.....	25

11 Sicherheitshinweise

- Vor der Inbetriebnahme die Betriebsanleitung lesen.
-  Anschluss, Montage und Einstellung nur durch Fachpersonal.
- Kein Sicherheitsbauteil gemäß EU-Maschinenrichtlinie.
- Power supply: Class 2
Enclosure type 1
- Gerät bei Inbetriebnahme vor Feuchte und Verunreinigung schützen.
- Diese Betriebsanleitung enthält Informationen, die während des Lebenszyklus des Sensors notwendig sind.

12 Bestimmungsgemäße Verwendung

Die GRSE18(S)V ist eine optoelektronische Einweg-Lichtschranke (im Folgenden Sensor genannt) und wird zum optischen, berührungslosen Erfassen von Sachen, Tieren und Personen eingesetzt. Zum Betrieb ist ein Sender (WS) und ein Empfänger (WE) erforderlich. Bei jeder anderen Verwendung und bei Veränderungen am Produkt verfällt jeglicher Gewährleistungsanspruch gegenüber der SICK AG.

13 Bedien- und Anzeigeelemente

Tabelle 8: Maßzeichnungen



Abbildung 12: Kurzbaufom, Anschlussleitung



Abbildung 13: Kurzbaufom, Stecker M12

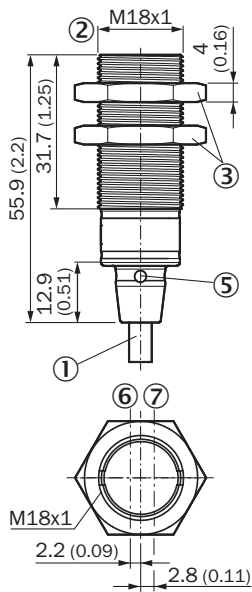

Abbildung 14: Kurzbaufom, Poti, Anschlussleitung

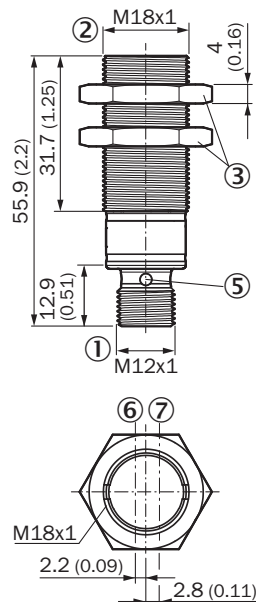

Abbildung 15: Kurzbaufom, Poti, Stecker M12

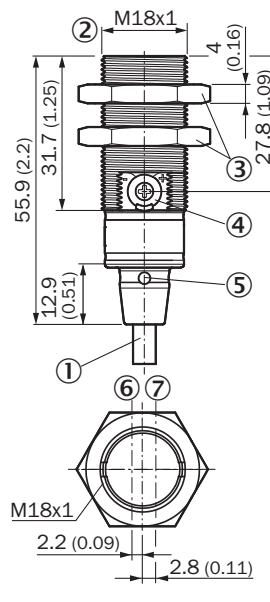

Abbildung 16: Langbauform, Anschlussleitung

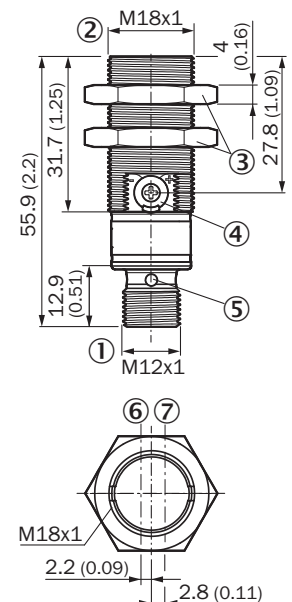

Abbildung 17: Langbauform, Stecker M12

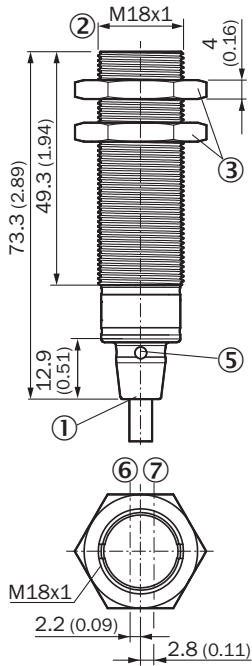

Abbildung 18: Langbauform, Poti, Anschlussleitung

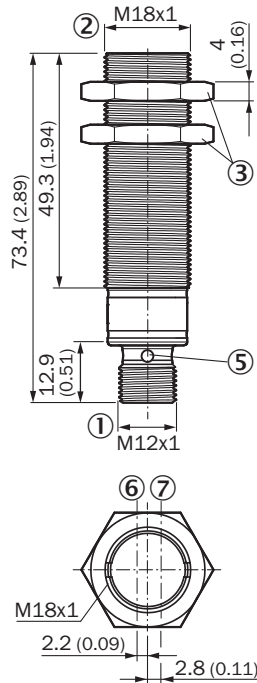

Abbildung 19: Langbauform, Poti, Stecker M12

- ① Anschluss
- ② Befestigungsgewinde M18 x 1
- ③ Befestigungsmutter (2 x); WS24, Edelstahl
- ④ Potentiometer, 270°
- ⑤ Anzeige-LED (4 x)
- ⑥ Optikachse, Empfänger
- ⑦ Optikachse, Sender

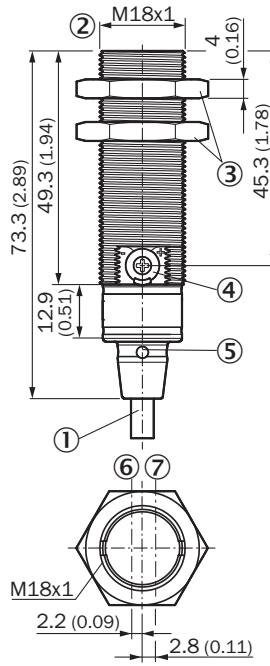

Abbildung 20: Bedienelement: Empfindlichkeitseinstellung

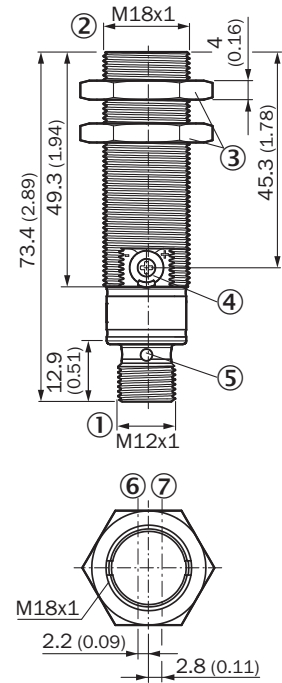
14 Montage

Sensoren (Sender und Empfänger) an geeignete Befestigungswinkel montieren (siehe SICK-Zubehör-Programm). Sender und Empfänger zueinander ausrichten.

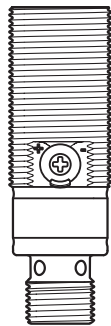
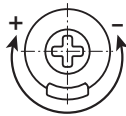
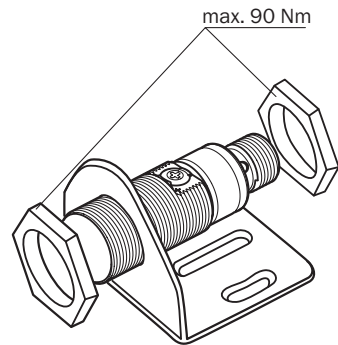

Maximal zulässiges Anzugsdrehmoment des Sensors von 90 Nm beachten.



HINWEIS

Bei jeder zweiten Einweg-Lichtschanke die Anordnung von Sender und Empfänger tauschen, bzw. genügend Abstand zwischen den Einweg-Lichtschanken einhalten.



Abbildung 21: Anordnung von mehreren Einweg-Lichtschanken

15 Elektronische Installation

Anschluss der Sensoren muss spannungsfrei ($U_V = 0\text{ V}$) erfolgen. Je nach Anschlussart sind die folgenden Informationen zu beachten:

- Steckeranschluss: Pinbelegung
- Leitung: Adernfarbe

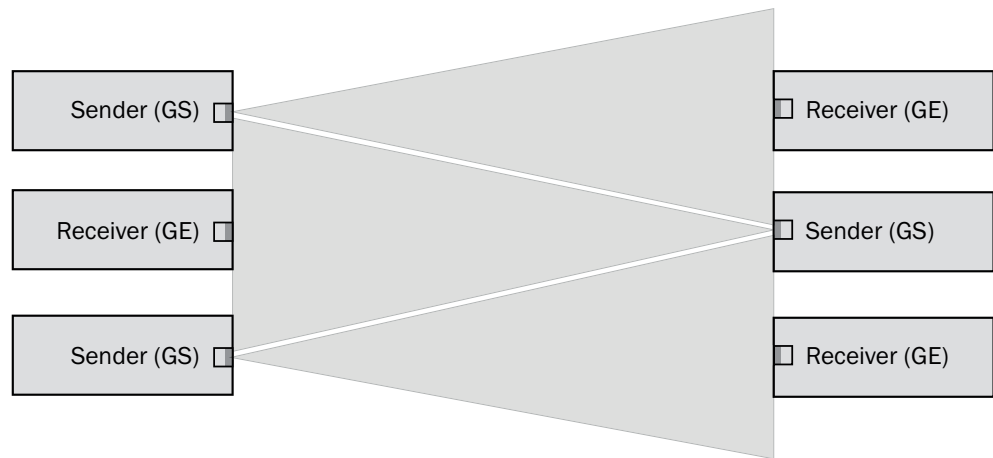
Erst nach Anschluss aller elektrischen Verbindungen die Spannungsversorgung ($U_V > 0\text{ V}$) anlegen bzw. einschalten. Am Sensor leuchtet die grüne Anzeige-LED.

Erläuterungen zum Anschlussschema (Tabellen 2 und 3):

Q / \bar{Q} = Schaltausgänge

TE / Test = Testeingang (siehe Tabelle 12)

n. c. = nicht angeschlossen

DC: 10... 30 V DC, siehe „Technische Daten“, Seite 25

Tabelle 9: DC, GRS



GRS18(S)V	D11xxx	D13x2/4x	D13x1/3x	D24xxx	D23xd/4x	D23x1/3x
1	+ (L+)	+ (L+)	+ (L+)	+ (L+)	+ (L+)	+ (L+)
2	n. c.	n. c.	n. c.	n. c.	n. c.	n. c.
3	- (M)	- (M)	- (M)	- (M)	- (M)	- (M)
4	Test	Test	n. c.	Q	Test	n. c.
	 1 = brn 2 = wht 3 = blu 4 = blk 0.14 mm ² AWG26	 1 = brn 2 = wht 3 = blu 4 = blk 0.14 mm ² AWG26				

Tabelle 10: DC, GRE

GRE18(S)V	x11xxx	x13xxx	x24xxx	x23xxx
1	+ (L+)	+ (L+)	+ (L+)	+ (L+)
2	\bar{Q}	n. c.	\bar{Q}	n. c.
3	- (M)	- (M)	- (M)	- (M)
4	Q	Q	Q	Q
	 1 = brn 2 = wht 3 = blu 4 = blk 0.14 ... 1.5 mm ² AWG26	 1 = brn - 3 = blu 4 = blk 0.14 ... 1.5 mm ² AWG26		

Tabelle 11: DC

PNP: Q (≤ 100 mA)		
NPN: Q (≤ 100 mA)		
PNP: \bar{Q} (≤ 100 mA)		
NPN: \bar{Q} (≤ 100 mA)		

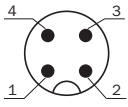
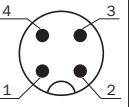
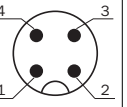
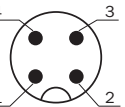
Tabelle 12: Test

	Test

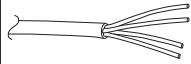
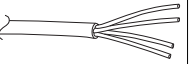
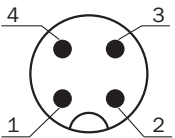
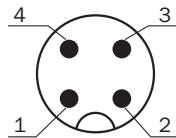
16 Inbetriebnahme

1 Ausrichtung

Sender auf Empfänger ausrichten. Positionierung so wählen, dass der rote Sendelichtstrahl auf den Empfänger auftrifft. Tipp: Weißes Papier oder Reflektor als Ausrichthilfe verwenden. Der Sender muss freie Sicht auf den Empfänger haben, es darf sich kein Objekt im Strahlengang befinden [siehe [Abbildung](#)]. Es ist darauf zu achten, dass die optischen Öffnungen (Frontscheiben) der Sensoren vollständig frei sind.

Sender auf Empfänger ausrichten. Positionierung so wählen, dass das Infrarotlicht (nicht sichtbar) auf den Empfänger auftrifft. Die korrekte Ausrichtung kann nur über die AnzeigeleDs erkannt werden. Siehe dazu [Abbildung](#) und [Tabelle 11](#). Der Sender muss freie Sicht auf den Empfänger haben, es darf sich kein Objekt im Strahlengang befinden. Es ist darauf zu achten, dass die optischen Öffnungen (Frontscheiben) der Sensoren vollständig frei sind.



Abbildung: Ausrichtung

2 Schaltabstand

Einsatzbedingungen beachten: Distanz zwischen Sender und Empfänger mit dem zugehörigen Diagramm [siehe [Abbildung 0](#)] abgleichen (x = Schaltabstand, y = Funktionsreserve). Beim Einsatz von mehreren Einweg-Lichtschranken, die nebeneinander installiert werden, empfehlen wir, bei jeder zweiten Einweg-Lichtschranke die Anordnung von Sender und Empfänger zu tauschen, bzw. genügend Abstand zwischen den Einweg-Lichtschranken einzuhalten. Damit können gegenseitige Beeinflussungen vermieden werden [siehe [Abbildung 21](#)].

Operating reserve

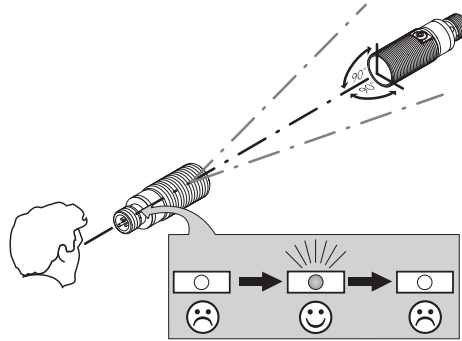
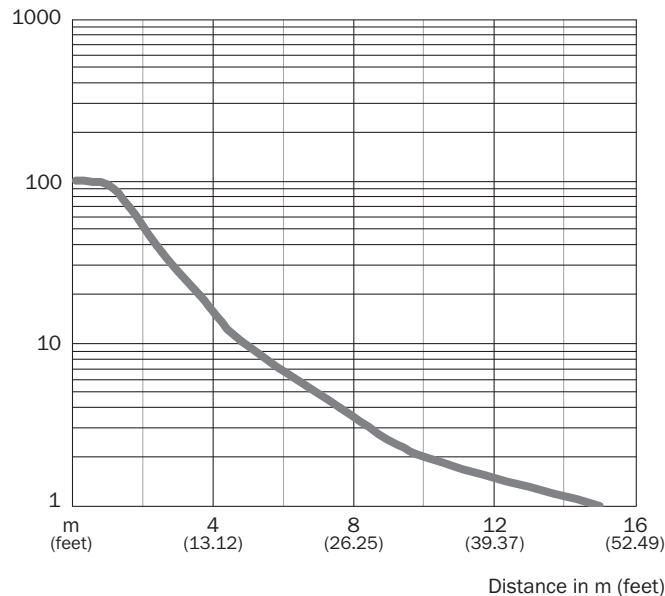

Zur Überprüfung der Funktion und Tabelle 3 heranziehen. Verhält sich der Schaltausgang nicht gemäß Tabelle 3, Einsatzbedingungen prüfen. Siehe Abschnitt Fehlerdiagnose.



Abbildung 22: Schaltabstand

Tabelle 13: Definition Schaltabstand

	GRSE18(S)V
①	0 ... 15 m

① Schaltabstand

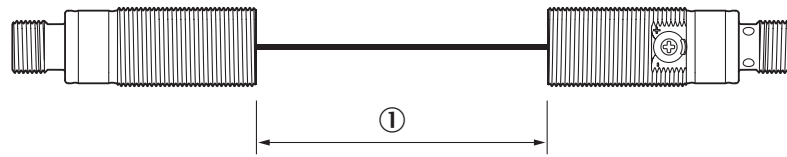
3 Einstellung Empfindlichkeit

Sensor ohne Einstellmöglichkeit: Sensor ist eingestellt und betriebsbereit.

Mit dem Potentiometer (Art: 270°) wird die Empfindlichkeit eingestellt. Drehung nach rechts: Erhöhung der Funktionsreserve, Drehung nach links: Verringerung der Funktionsreserve. Wir empfehlen, das Potentiometer auf "Maximal" zu stellen.

Sensor ist eingestellt und betriebsbereit.

4 Testeingang

Testeingang: Die Sensoren GRSE18(S)V verfügen über einen Testeingang („TE“ oder „Test“ im Anschlussschema [Tabelle 9]), mit dem der Sender ausgeschaltet und somit die ordnungsgemäße Funktion des Sensors überprüft werden kann: Bei Verwendung von Leitungsdosen mit LED-Anzeigen ist darauf zu achten, dass der TE entsprechend belegt ist. Es darf sich kein Objekt zwischen Sender und Empfänger befinden, Testeingang aktivieren (siehe Anschlussschema [Tabelle 9], TE nach 0 V). Sende-LED wird abgeschaltet, bzw. es wird simuliert, dass ein Objekt erkannt wird. Zur Überprüfung der Funktion die folgende Tabelle heranziehen. Verhält sich der Schaltausgang nicht gemäß der folgenden Tabelle, Einsatzbedingungen prüfen. Siehe Abschnitt Fehlerdiagnose.

17 Störungsbehebung

Tabelle Störungsbehebung zeigt, welche Maßnahmen durchzuführen sind, wenn die Funktion des Sensors nicht mehr gegeben ist.

17.1 Tabelle Störungsbehebung

Tabelle 14: Störungsbehebung

Anzeige-LED / Fehlerbild	Ursache	Maßnahme
grüne LED leuchtet nicht	keine Spannung oder Spannung unterhalb der Grenzwerte	Spannungsversorgung prüfen, den gesamten elektrischen Anschluss prüfen (Leitungen und Steckerverbindungen)
grüne LED leuchtet nicht	Spannungsunterbrechungen	Sicherstellen einer stabilen Spannungsversorgung ohne Unterbrechungen
grüne LED leuchtet nicht	Sensor ist defekt	Wenn Spannungsversorgung in Ordnung ist, dann Sensor austauschen
grüne LED leuchtet, kein Ausgangssignal bei Objektdetektion	Testeingang (Test) ist nicht korrekt angeschlossen	Siehe Hinweis für Anschluss des TE

Anzeige-LED / Fehlerbild	Ursache	Maßnahme
gelbe LED blinkt	Sensor ist noch betriebsbereit, aber die Betriebsbedingungen sind nicht optimal	Betriebsbedingungen prüfen: Lichtstrahl (Lichtfleck) vollständig auf den Empfänger ausrichten / Reinigung der optischen Flächen / Empfindlichkeit (Potentiometer) neu einstellen / falls Potentiometer auf max. Empfindlichkeit eingestellt: Abstand zwischen Sender und Empfänger verringern / Schaltabstand überprüfen und ggf. anpassen, siehe Tabelle 13 .
gelbe LED leuchtet, kein Objekt im Strahlengang	Der Lichtstrahl einer Einweg-Lichtschranke trifft auf den Empfänger einer anderen (benachbarten) Einweg-Lichtschranke	Bei jeder zweiten Einweg-Lichtschranke die Anordnung von Sender und Empfänger tauschen, bzw. genügend Abstand zwischen den Einweg-Lichtschranken einhalten, siehe Abbildung 21 .

18 Demontage und Entsorgung

Die Entsorgung des Sensors hat gemäß den länderspezifisch anwendbaren Vorschriften zu erfolgen. Für die enthaltenen Wertstoffe (insbesondere Edelmetalle) ist im Rahmen der Entsorgung eine Verwertung anzustreben.

19 Wartung

SICK-Sensoren sind wartungsfrei.

Wir empfehlen, in regelmäßigen Abständen

- die optischen Grenzflächen zu reinigen
- Verschraubungen und Steckverbindungen zu überprüfen

Veränderungen an Geräten dürfen nicht vorgenommen werden.

Irrtümer und Änderungen vorbehalten. Angegebene Produkteigenschaften und technische Daten stellen keine Garantieerklärung dar.

20 Technische Daten

	GRSE18(S)-xxx2xV, Infraredlight	GRSE18(S)-xxx4xV, visible red light
Schaltabstand	0 ... 10 m	0 ... 10 m
Schaltabstand max.	0 ... 15 m	0 ... 15 m
Lichtfleckdurchmesser/Entfernung	420 mm / 10 m	250 mm / 10 m
Versorgungsspannung U_V	DC 10 ... 30 V ²	DC 10 ... 30 V ²
Ausgangsstrom I_{max}	100 mA	100 mA
Schaltfolge max.	1,000 / s ⁵	1,000 / s ⁵
Ansprechzeit max.	< 0,5 ms ⁶	< 0,5 ms ⁶
Schutzart	IP67,IP68,IP69K ¹¹	IP67,IP68,IP69K ¹¹
Schutzklasse	III ⁸	III ⁸
Schutzschaltungen	A,B,D ¹⁰	A,B,D ¹⁰
Betriebsumgebungstemperatur	-25 °C ... +55 °C	-25 °C ... +55 °C

- 1 Tastgut mit 90 % Remission (bezogen auf Standard-Weiß DIN 5033)
- 2 Grenzwerte; Betrieb im kurzschlussgeschützten Netz max. 8 A; Restwelligkeit max. 5 V_{ss}
- 4 Gebrauchskategorie: AC-15, DC-13 (EN 60947-1)
- 5 Mit Hell- / Dunkelverhältnis 1:1
- 6 Signallaufzeit bei ohmscher Last
- 7 gültig für Q\ auf Pin2, wenn per Software konfiguriert
- 8 Bemessungsspannung DC 50 V
- 10 A = U_V-Anschlüsse verpolsicher
 B = Ein- und Ausgänge verpolsicher
 D = Ausgänge überstrom- und kurzschlussfest
- 11 IP68: Nach EN 60529 (10 m Wassertiefe / 24 h).
 IP69K: Nach ISO 20653:2013-03.

GRSE18(S)V

Capteurs photoélectriques cylindriques



de
en
es
fr
it
ja
pt
ru
zh

Produit décrit

GR18 Inox
GRSE18(S)V

Fabricant

SICK AG
Erwin-Sick-Straße 1
79183 Waldkirch
Allemagne

Site de fabrication

SICK, Malaisie

Remarques juridiques

Cet ouvrage est protégé par les droits d'auteur. Les droits établis restent dévolus à la société SICK AG. La reproduction de l'ouvrage, même partielle, n'est autorisée que dans le cadre légal prévu par la loi sur les droits d'auteur. Toute modification, tout abrègement ou toute traduction de l'ouvrage est interdit sans l'accord écrit exprès de la société SICK AG.

Les marques citées dans ce document sont la propriété de leurs détenteurs respectifs.

© SICK AG. Tous droits réservés.

Document original

Ce document est un document original de SICK AG.



Contenu

21	Instructions de sécurité.....	29
22	Utilisation conforme.....	29
23	Éléments de commande et d'affichage.....	29
24	Montage.....	30
25	Installation électronique.....	31
26	Mise en service.....	34
27	Élimination des défauts.....	35
27.1	Tableau Suppression des défaillances.....	35
28	Démontage et mise au rebut.....	36
29	Maintenance.....	36
30	Caractéristiques techniques.....	37

21 Instructions de sécurité

- Lire la notice d'instruction avant la mise en service.
-  Confier le raccordement, le montage et le réglage uniquement au personnel qualifié.
- Il ne s'agit pas d'un composant de sécurité au sens de la directive machines CE.
- Power supply: Class 2
Enclosure type 1
- Protéger l'appareil contre l'humidité et les impuretés lors de la mise en service.
- Cette notice d'instruction contient des informations nécessaires pendant toute le cycle de vie du capteur.

22 Utilisation conforme

GRSE18(S)V est une barrière émetteur-récepteur optoélectronique (appelée capteur dans ce document) qui permet la détection optique sans contact d'objets, d'animaux et de personnes. Un émetteur (WS) et un récepteur (WE) sont nécessaires à son fonctionnement. Toute autre utilisation ou modification du produit annule la garantie de SICK AG.

23 Éléments de commande et d'affichage

Tableau 15: Plans cotés

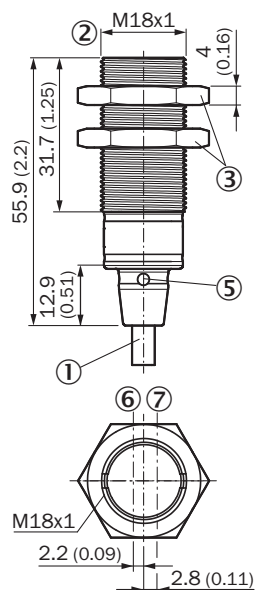

Illustration 23: Forme courte, câble de raccordement

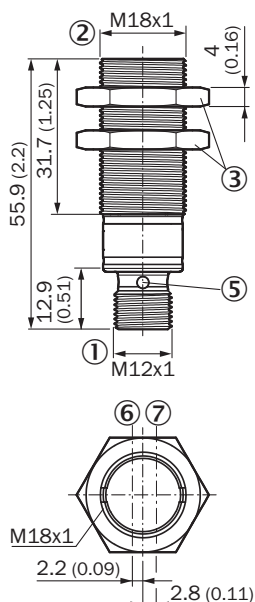

Illustration 24: Forme courte, connecteur mâle M12

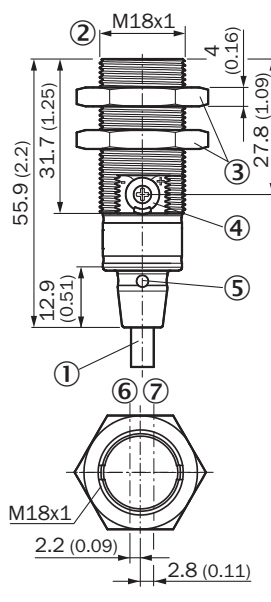

Illustration 25: Forme courte, potentiomètre, câble de raccordement

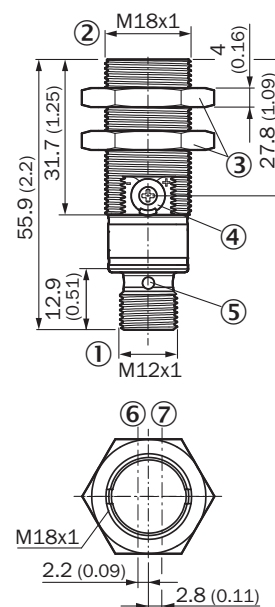

Illustration 26: Forme courte, potentiomètre, connecteur mâle M12

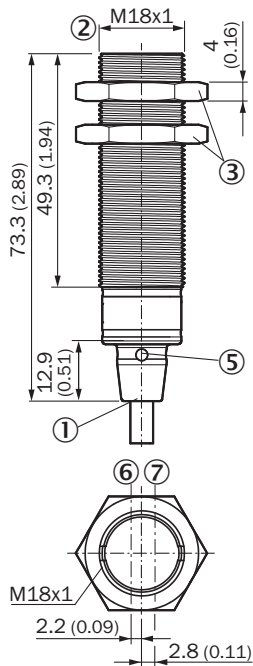

Illustration 27: Forme longue, câble de raccordement

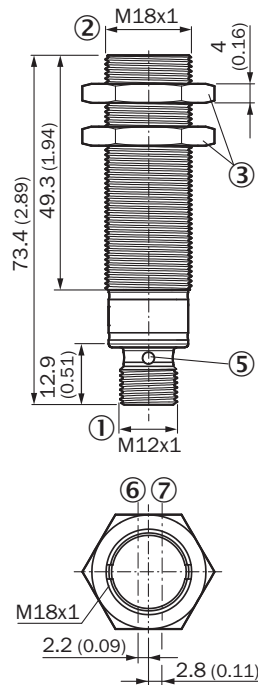

Illustration 28: Forme longue, connecteur mâle M12

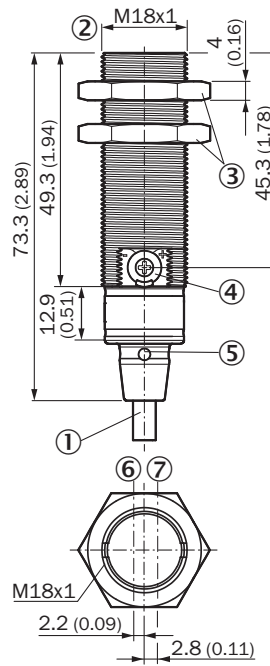

Illustration 29: Forme longue, potentiomètre, câble de raccordement

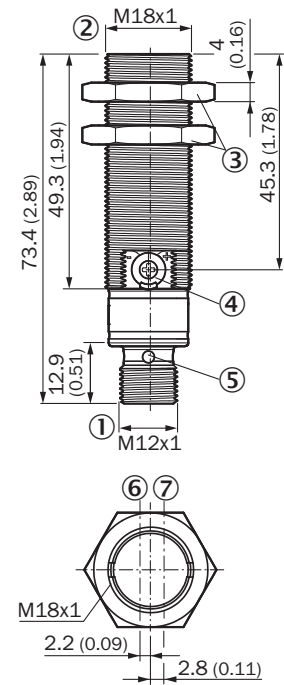

Illustration 30: Forme longue, potentiomètre, connecteur mâle M12

- ① Raccordement
- ② Filetage de fixation M18 x 1
- ③ Écrou de fixation (2 x) ; WS24, acier inoxydable
- ④ Potentiomètre, 270°
- ⑤ LED témoin (4 x)
- ⑥ Axe optique, récepteur
- ⑦ Axe optique, émetteur

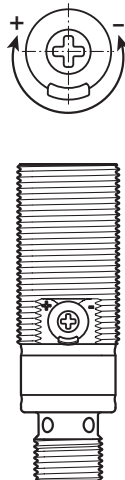
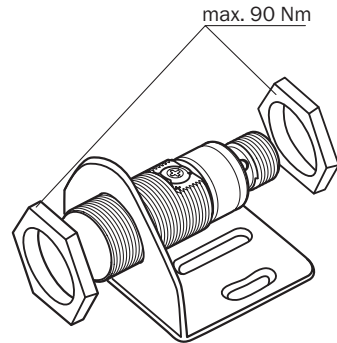

Illustration 31: Éléments de commande : Réglage de la sensibilité

24 Montage

Monter les capteurs (émetteur et récepteur) sur un étrier adapté (voir la gamme d’accessoires SICK). Aligner l’émetteur et sur le récepteur.



Respecter le couple de serrage maximum autorisé du capteur de 90 Nm



REMARQUE

Pour une barrière émetteur-récepteur sur deux, intervertir la place de l'émetteur et du récepteur ou laisser suffisamment d'espace entre les barrières émetteur-récepteur.

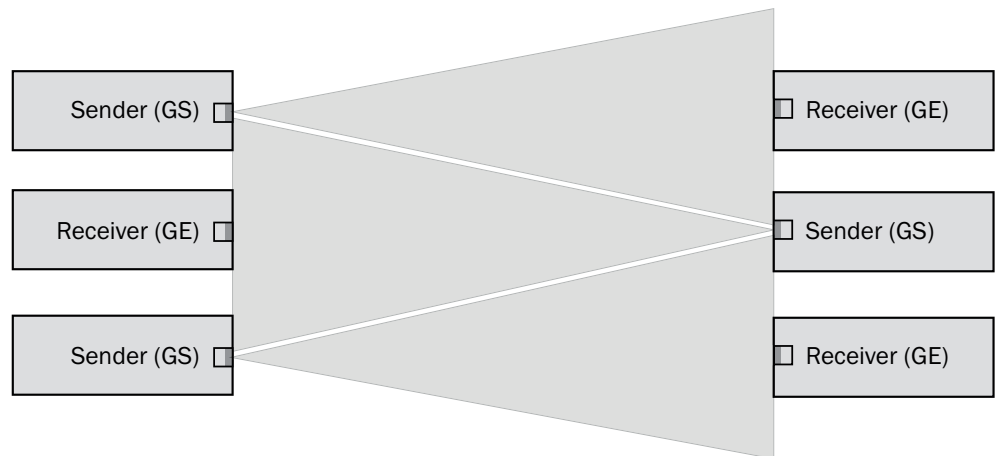

Illustration 32: Disposition de plusieurs barrières émetteur-récepteur

25 Installation électronique

Le raccordement des capteurs doit s'effectuer hors tension ($U_v = 0\text{ V}$). Selon le mode de raccordement, respecter les informations suivantes :

- Raccordement du connecteur : affectation des broches
- Câble : couleur des fils

Après avoir terminé tous les raccordements électriques, appliquer ou activer l'alimentation électrique ($U_v > 0\text{ V}$). La LED verte s'allume sur le capteur.

Explications du schéma de raccordement (tableaux 2 et 3) :

Q / \bar{Q} = sorties de commutation

TE / Test = entrée test (voir tableau 19)

n. c. = non connecté

CC : 10 ... 30 V CC, voir „Caractéristiques techniques“, page 37

Tableau 16: CC, GRS





GRS18(S)V	D11xxx	D13x2/4x	D13x1/3x	D24xxx	D23xd/4x	D23x1/3x
1	+ (L+)	+ (L+)	+ (L+)	+ (L+)	+ (L+)	+ (L+)
2	n. c.	n. c.	n. c.	n. c.	n. c.	n. c.
3	- (M)	- (M)	- (M)	- (M)	- (M)	- (M)
4	Test	Test	n. c.	Q	Test	n. c.
 	 1 = brn (marron) 2 = wht (blanc) 3 = blu (bleu) 4 = blk (noir) 0,14 mm ² AWG26	 1 = brn (marron) 2 = wht (blanc) 3 = blu (bleu) 4 = blk (noir) 0,14 mm ² AWG26				

Tableau 17: CC, GRE

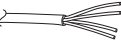

GRE18(S)V	x11xxx	x13xxx	x24xxx	x23xxx
1	+ (L+)	+ (L+)	+ (L+)	+ (L+)
2	\bar{Q}	n. c.	\bar{Q}	n. c.
3	- (M)	- (M)	- (M)	- (M)
4	Q	Q	Q	Q
 	 1 = brn (marron) 2 = wht (blanc) 3 = blu (bleu) 4 = blk (noir) 0,14 ... 1,5 mm ² AWG26	 1 = brn (marron) - 3 = blu (bleu) 4 = blk (noir) 0,14 ... 1,5 mm ² AWG26		

Tableau 18: CC

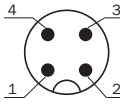
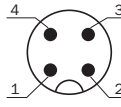
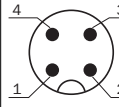
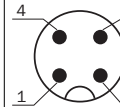
PNP : Q (≤ 100 mA)		
NPN : Q (≤ 100 mA)		
PNP : \bar{Q} (≤ 100 mA)		
NPN : \bar{Q} (≤ 100 mA)		

Tableau 19: Test

	Test

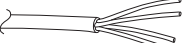
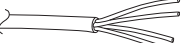
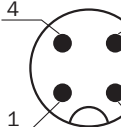
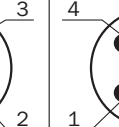
26 Mise en service

1 Alignement

Aligner l'émetteur sur le récepteur. Choisir la position de sorte que le faisceau lumineux émis rouge touche le récepteur. Conseil : utiliser un morceau de papier blanc ou le réflecteur comme outil d'alignement. L'émetteur doit disposer d'un champ de vision dégagé sur le récepteur, il ne doit donc y avoir aucun objet dans la trajectoire du faisceau [voir illustration]. S'assurer que les ouvertures optiques (vitres frontales) des capteurs sont parfaitement dégagées.

Aligner l'émetteur sur le récepteur. Choisir la position de sorte que le faisceau infrarouge (invisible) touche le récepteur. Seules les LED permettent de savoir si l'alignement est correct. Voir illustration et tableau 18. L'émetteur doit disposer d'un champ de vision dégagé sur le récepteur, il ne doit donc y avoir aucun objet dans la trajectoire du faisceau. S'assurer que les ouvertures optiques (vitres frontales) des capteurs sont parfaitement dégagées.

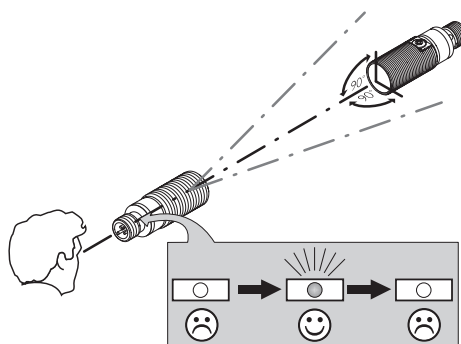
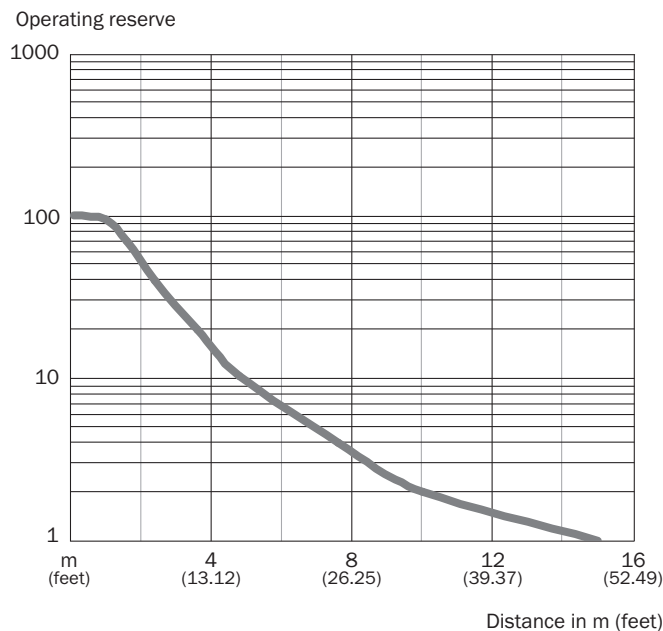

Illustration: Alignement

2 Distance de commutation

Respecter les conditions d'utilisation : comparer la distance entre l'émetteur et le récepteur avec le diagramme correspondant [voir illustration 0] (x = distance de commutation, y = réserve de fonctionnement).

Si plusieurs barrières émetteur-récepteur sont installées les unes à côté des autres, nous recommandons d'intervir la place de l'émetteur et du récepteur une fois sur deux ou de laisser suffisamment d'espace entre les barrières émetteur-récepteur. Ceci permet d'éviter les interférences mutuelles [voir illustration 32].



Pour vérifier le fonctionnement, utiliser le tableau 3. Si la sortie de commutation ne se comporte pas comme indiqué dans le tableau 3, vérifier les conditions d'utilisation. Voir la section consacrée au diagnostic.



Illustration 33: Distance de commutation

Tableau 20: Définition de la distance de commutation

	GRSE18(S)V
①	0 ... 15 m

① Distance de commutation

3 Réglage de la sensibilité

Capteur sans possibilité de réglage : le capteur est réglé et prêt à l'emploi.

La sensibilité se règle avec le potentiomètre (réf : 270°). Rotation vers la droite : augmentation de la réserve de fonctionnement, rotation vers la gauche : réduction de la réserve de fonctionnement. Nous recommandons de régler le potentiomètre sur « Maximum ».

Le capteur est réglé et prêt à l'emploi.

4 Entrée test

Entrée test : les capteurs GRSE18(S)V disposent d'une entrée test (« TE » ou « Test » sur le schéma de raccordement [tableau 16]) qui permet de désactiver le capteur et ainsi de contrôler son bon fonctionnement : lorsque des câbles avec connecteurs femelles équipés de LED sont utilisés, s'assurer que l'entrée TE est correctement affectée.

Aucun objet ne doit se trouver entre l'émetteur et le récepteur ; activer l'entrée test (voir le schéma de raccordement [tableau 16], TE sur 0 V). La LED d'émission s'éteint ou une détection d'objet est simulée. Pour vérifier le fonctionnement, utiliser le tableau suivant. Si la sortie de commutation ne se comporte pas comme indiqué dans le tableau suivant, vérifier les conditions d'utilisation. Voir la section consacrée au diagnostic.

27 Élimination des défauts

Le tableau Élimination des défauts présente les mesures à appliquer si le capteur ne fonctionne plus.

27.1 Tableau Suppression des défaillances

Tableau 21: Élimination des défauts

LED d'état / image du défaut	Cause	Mesure
La LED verte ne s'allume pas	Pas de tension ou tension inférieure aux valeurs limites	Contrôler l'alimentation électrique, contrôler tous les branchements électriques (câbles et connexions)
La LED verte ne s'allume pas	Coupures d'alimentation électrique	S'assurer que l'alimentation électrique est stable et ininterrompue
La LED verte ne s'allume pas	Le capteur est défectueux	Si l'alimentation électrique est en bon état, remplacer le capteur
La LED verte s'allume, pas de signal de sortie en cas de détection d'objet	L'entrée test (Test) n'est pas correctement raccordée	Voir les informations sur le raccordement de l'entrée test

LED d'état / image du défaut	Cause	Mesure
La LED jaune clignote	Le capteur est encore opérationnel, mais les conditions d'utilisation ne sont pas idéales	Vérifier les conditions d'utilisation : Diriger le faisceau lumineux (spot lumineux) entièrement sur le récepteur / Nettoyage des surfaces optiques / Régler à nouveau la sensibilité (potentiomètre) / Si le potentiomètre est réglé sur la sensibilité max. : réduire la distance entre l'émetteur et le récepteur/ Contrôler la distance de commutation et éventuellement l'adapter, voir tableau 20 .
La LED jaune s'allume, pas d'objet dans la trajectoire du faisceau	Le faisceau lumineux d'une barrière émetteur-récepteur atteint le récepteur d'une autre barrière émetteur-récepteur (voisine)	Pour une barrière émetteur-récepteur sur deux, intervertir la place de l'émetteur et du récepteur ou laisser suffisamment d'espace entre les barrières émetteur-récepteur, voir illustration 32 .

28 Démontage et mise au rebut

La mise au rebut du capteur doit respecter la réglementation nationale en vigueur. Dans le cadre de la mise au rebut, veiller à recycler les matériaux (notamment les métaux précieux).

29 Maintenance

Les capteurs SICK ne nécessitent aucune maintenance.

Nous vous recommandons de procéder régulièrement

- au nettoyage des surfaces optiques
- au contrôle des vissages et des connexions enfichables

Ne procéder à aucune modification sur les appareils.

Sujet à modification sans préavis. Les caractéristiques du produit et techniques fournies ne sont pas une déclaration de garantie.

30 Caractéristiques techniques

	GRSE18(S)-xxx2xV, Infraredlight	GRSE18(S)-xxx4xV, visible red light
Distance de commutation	0 ... 10 m	0 ... 10 m
Portée max.	0 ... 15 m	0 ... 15 m
Diamètre spot / distance	420 mm / 10 m	250 mm / 10 m
Tension d'alimentation U_V	DC 10 ... 30 V ²	DC 10 ... 30 V ²
Courant de sortie I_{max}	100 mA	100 mA
Commutation max.	1,000 / s ⁵	1,000 / s ⁵
Temps de réponse max.	< 0,5 ms ⁶	< 0,5 ms ⁶
Indice de protection	IP67,IP68,IP69K ¹¹	IP67,IP68,IP69K ¹¹
Classe de protection	III ⁸	III ⁸
Protections électriques	A,B,D ¹⁰	A,B,D ¹⁰
Température de service	-25 °C ... +55 °C	-25 °C ... +55 °C

- 1 Tastgut mit 90 % Remission (bezogen auf Standard-Weiß DIN 5033)
 2 Grenzwerte; Betrieb im kurzschlussgeschützten Netz max. 8 A; Restwelligkeit max. 5 V_{ss}
 4 Gebrauchskategorie: AC-15, DC-13 (EN 60947-1)
 5 Mit Hell- / Dunkelverhältnis 1:1
 6 Signallaufzeit bei ohmscher Last
 7 gültig für Q\ auf Pin2, wenn per Software konfiguriert
 8 Bemessungsspannung DC 50 V
 10 A = U_V-Anschlüsse verpolsicher
 B = Ein- und Ausgänge verpolsicher
 D = Ausgänge überstrom- und kurzschlussfest
 11 IP68 : selon EN 60529 (profondeur d'eau 10 m / 24 h).
 IP69K : selon ISO 20653:2013-03.

GRSE18(S)V

Barreira de luz cilíndrica

SICK
Sensor Intelligence.



de
en
es
fr
it
ja
pt
ru
zh

Produto descrito

GR18 Inox
GRSE18(S)V

Fabricante

SICK AG
Erwin-Sick-Str. 1
79183 Waldkirch
Alemanha

Local de fabricação

SICK, Malásia

Notas legais

Reservados os direitos autorais do presente documento. Todos os direitos permanecem em propriedade da empresa SICK AG. A reprodução total ou parcial desta obra só é permitida dentro dos limites regulamentados pela Lei de Direitos Autorais. É proibido alterar, resumir ou traduzir esta obra sem a autorização expressa e por escrito da SICK AG.

As marcas citadas neste documento são de propriedade de seus respectivos proprietários.

© SICK AG. Todos os direitos reservados

Documento original

Este é um documento original da SICK AG.



Índice

31	Avisos de segurança.....	41
32	Especificações de uso.....	41
33	Elementos de comando e indicação.....	41
34	Montagem.....	42
35	Instalação elétrica.....	43
36	Colocação em operação.....	46
37	Eliminação de falhas.....	47
	37.1 Tabela de eliminação de falhas.....	47
38	Desmontagem e descarte.....	48
39	Manutenção.....	48
40	Dados técnicos.....	49

31 Avisos de segurança

- Ler o manual de instruções antes da colocação em operação.
-  A conexão, a montagem e o ajuste devem ser executados somente por pessoal técnico qualificado.
- Este não é um componente de segurança conforme a Diretriz de Máquinas Europeia.
- Power supply: Class 2
Enclosure type 1
- Durante a colocação em operação, manter o aparelho protegido contra impurezas e umidade.
- Este manual de instruções contém informações necessárias para toda a vida útil do sensor.

32 Especificações de uso

O GRSE18(S)V é uma barreira de luz unidirecional optoeletrônica (doravante denominada “sensor”) utilizada para a detecção óptica, sem contato, de objetos, animais e pessoas. Para a operação, são necessários um emissor (WS) e um receptor (WE). Qualquer utilização diferente ou alterações do produto ocasionam a perda da garantia da SICK AG.

33 Elementos de comando e indicação

Tabela 22: Desenhos dimensionais



Figura 34: Forma construtiva curta, cabo de conexão



Figura 35: Forma construtiva curta, conector M12

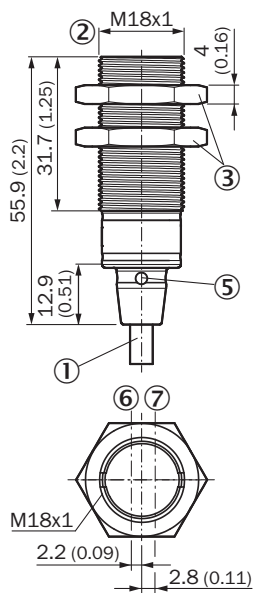

Figura 36: Forma construtiva curta, potenciômetro, cabo de conexão

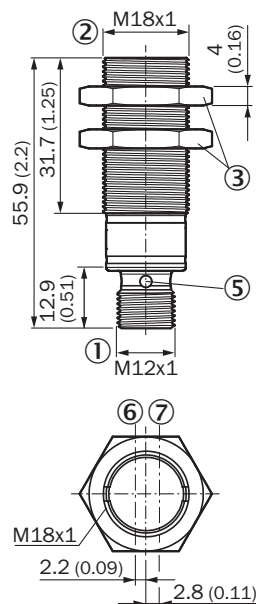

Figura 37: Forma construtiva curta, potenciômetro, conector M12

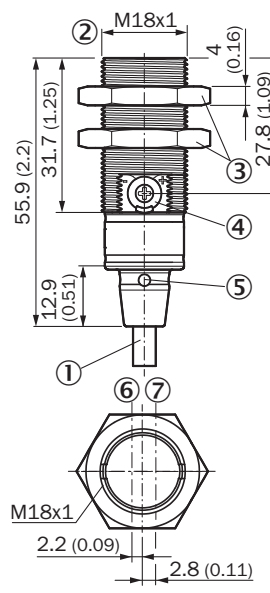

Figura 38: Forma construtiva longa, cabo de conexão

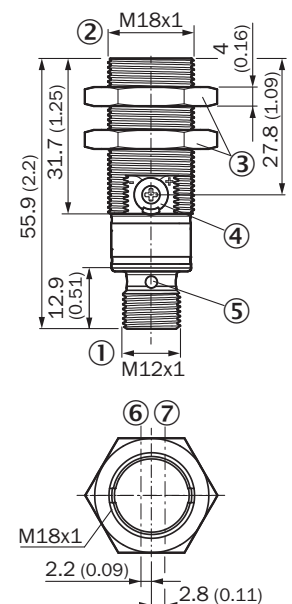

Figura 39: Forma construtiva longa, conector M12

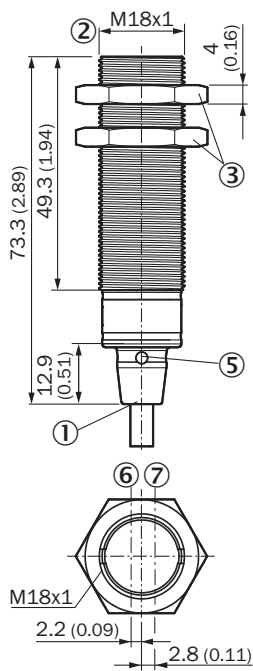

Figura 40: Forma construtiva longa, potenciômetro, cabo de conexão

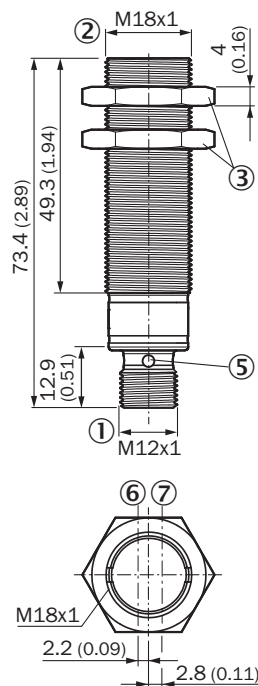

Figura 41: Forma construtiva longa, potenciômetro, conector M12

- ① Conexão
- ② Rosca de fixação M18 x 1
- ③ Porca de fixação (2 x); WS24, aço inoxidável
- ④ Potenciômetro, 270°
- ⑤ LED indicador (4 x)
- ⑥ Eixo do sistema óptico, receptor
- ⑦ Eixo do sistema óptico, emissor

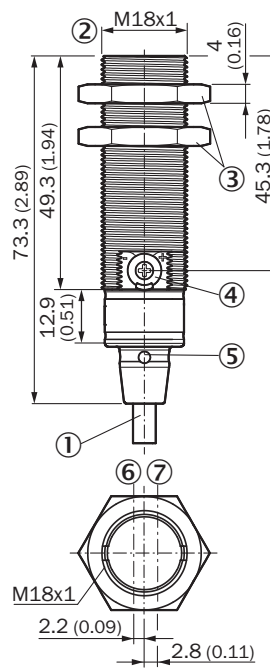

Figura 42: Elemento de comando: ajuste da sensibilidade

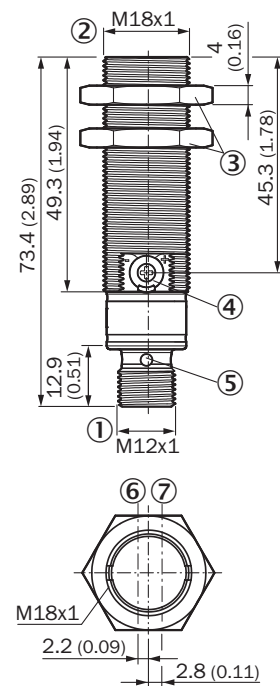
34 Montagem

Montar os sensores (emissor e receptor) em uma cantoneira de fixação adequada (ver a linha de acessórios SICK). Alinhar o emissor e o receptor entre si.

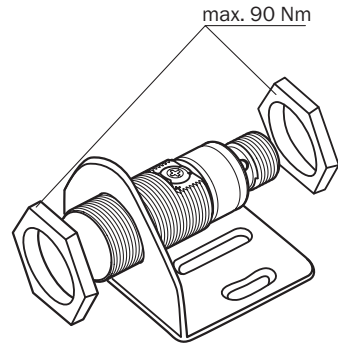

Observar o torque de aperto máximo permitido de 90 Nm para o sensor.



NOTA

Trocar a disposição do sensor e do receptor a cada duas barreiras de luz unidirecionais ou manter distância suficiente entre as barreira de luz unidirecionais.



Figura 43: Disposição de várias barreiras de luz unidirecionais

35 Instalação elétrica

A conexão dos sensores deve ser realizada em estado desenergizado ($U_V = 0\text{ V}$). Conforme o tipo de conexão, devem ser observadas as seguintes informações:

- Conector: Pin-out
- Cabo: Cor dos fios

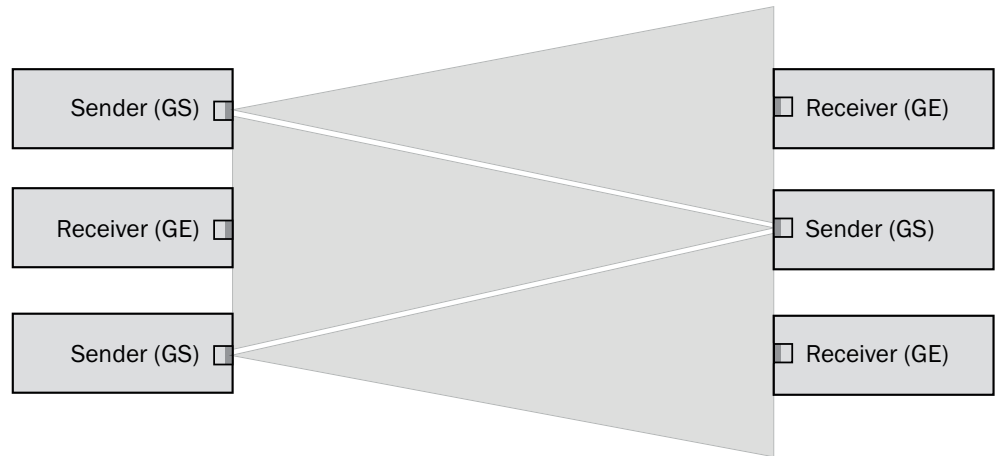
Instalar ou ligar a alimentação de tensão ($U_V > 0\text{ V}$) somente após a conexão de todas as conexões elétricas. O indicador LED verde está aceso no sensor.

Explicações relativas ao esquema de conexões (tabelas 2 e 3):

Q / \bar{Q} = saídas de comutação

TE / Test = Entrada de teste (ver tabela 26)

n. c. = não conectado

CC: 10 ... 30 V CC, ver „Dados técnicos“, página 49

Tabela 23: DC, GRS



GRS18(S)V	D11xxx	D13x2/4x	D13x1/3x	D24xxx	D23xd/4x	D23x1/3x
1	+ (L+)	+ (L+)	+ (L+)	+ (L+)	+ (L+)	+ (L+)
2	n. c.	n. c.	n. c.	n. c.	n. c.	n. c.
3	- (M)	- (M)	- (M)	- (M)	- (M)	- (M)
4	Testar	Testar	n. c.	Q	Testar	n. c.
	 1 = brn 2 = wht 3 = blu 4 = blk 0,14 mm ² AWG26	 1 = brn 2 = wht 3 = blu 4 = blk 0,14 mm ² AWG26				

Tabela 24: DC, GRE

GRE18(S)V	x11xxx	x13xxx	x24xxx	x23xxx
1	+ (L+)	+ (L+)	+ (L+)	+ (L+)
2	\bar{Q}	n. c.	\bar{Q}	n. c.
3	- (M)	- (M)	- (M)	- (M)
4	Q	Q	Q	Q
	 1 = brn 2 = wht 3 = blu 4 = blk 0,14 ... 1,5 mm ² AWG26	 1 = brn - 3 = blu 4 = blk 0,14 ... 1,5 mm ² AWG26		

Tabela 25: CC

PNP: Q (≤ 100 mA)		
NPN: Q (≤ 100 mA)		
PNP: \bar{Q} (≤ 100 mA)		
NPN: \bar{Q} (≤ 100 mA)		

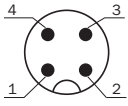
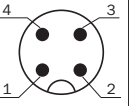
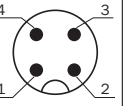
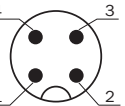
Tabela 26: Testar

		Testar

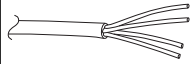
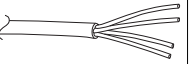
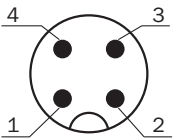
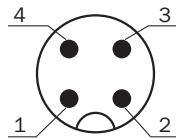
36 Colocação em operação

1 Alinhamento

Alinhar o emissor ao receptor. Selecionar o posicionamento de forma que o feixe da luz de emissão vermelho incida sobre o receptor. Dica: Utilizar um papel branco ou o refletor para auxiliar o alinhamento. O espaço entre o emissor e o receptor deve estar livre; não pode haver objetos no caminho óptico [ver figura]. Certificar-se de que as aberturas ópticas (vidros frontais) dos sensores refletor estejam completamente livres.

Alinhar o emissor ao receptor. Selecionar o posicionamento de forma que a luz infravermelha (invisível) incida sobre o receptor. O alinhamento correto só pode ser verificado através dos indicadores LED. Ver figura e tabela 25. O espaço entre o emissor e o receptor deve estar desimpedido; não pode haver objetos no caminho óptico. Certificar-se de que as aberturas ópticas (vidros frontais) dos sensores refletor estejam completamente livres.



Figura: Alinhamento

2 Distância de comutação

Observar as condições de uso: equiparar a distância entre o emissor e o receptor com o respectivo diagrama [ver figura 0] (x = distância de comutação, y = reserva operacional). Na utilização de várias barreiras de luz unidirecionais, instaladas lado a lado, recomendamos trocar a disposição do emissor e do receptor a cada duas barreiras de luz ou manter uma distância suficiente entre as barreiras de luz unidirecionais. Isto permite evitar interferências recíprocas [ver figura 43].

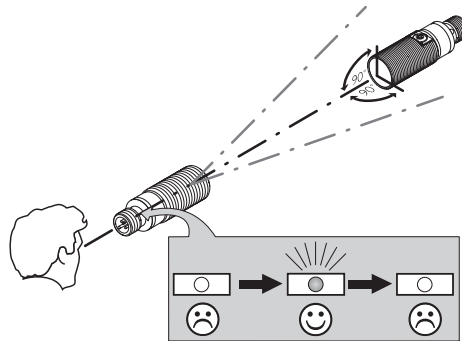
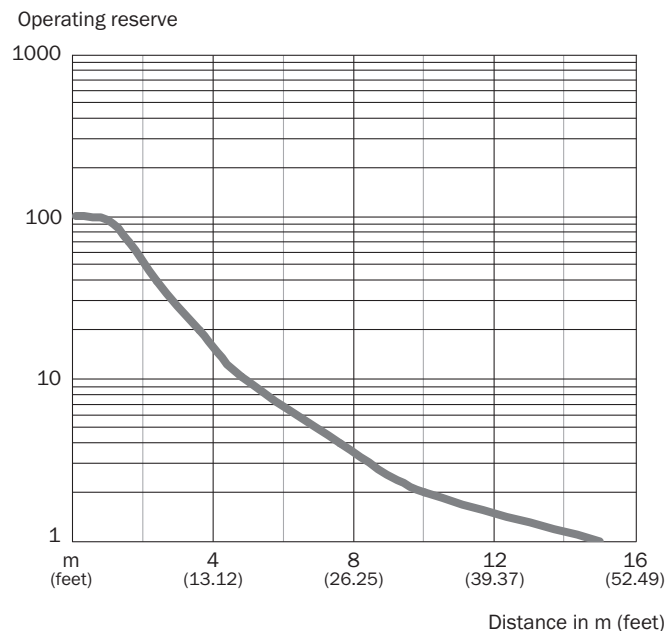

Para verificar a função, consultar e a tabela 3. Se a saída de comutação não se comportar de acordo com a tabela 3, verificar as condições de uso. Ver o item Diagnóstico de erros.



Figura 44: distância de comutação

Tabela 27: Definição distância de comutação

	GRSE18(S)V
①	0 ... 15 m

① Distância de comutação

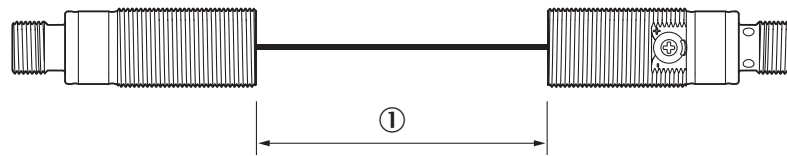
3 Ajuste da sensibilidade

Sensor sem possibilidade de ajuste: sensor está ajustado e operacional.

A sensibilidade é ajustada com o potenciômetro (tipo: 270°). Giro para direita: aumento da reserva operacional; giro para esquerda: redução da reserva operacional. Recomendamos ajustar o potenciômetro para “Máximo”.

O sensor está ajustado e operacional.

4 Entrada de teste

Entrada de teste: os sensores GRSE18(S)V dispõem de uma entrada de teste (“ET” ou “Teste” no esquema de conexões [tabela 23]), através da qual o sensor é desligado, permitindo assim verificar o seu funcionamento correto: ao utilizar conectores fêmea com indicadores LED, certificar-se de que a ET tenha o pin-out adequado.

Não pode haver nenhum objeto entre o emissor e o receptor, ativar a entrada de teste (ver o esquema de conexões [tabela 23], TE com 0 V). O LED de emissão é desligado ou há a simulação, de que um objeto foi detectado. Para verificar a função, consultar a tabela seguinte. Se a saída de comutação não se comportar de acordo com a tabela, verificar as condições de uso. Ver o item Diagnóstico de erros.

37 Eliminação de falhas

A tabela Eliminação de falhas mostra as medidas a serem executadas, quando o sensor não estiver funcionando.

37.1 Tabela de eliminação de falhas

Tabela 28: Eliminação de falhas

Indicador LED / padrão de erro	Causa	Medida
LED verde apagado	Sem tensão ou tensão abaixo dos valores-limite	Verificar a alimentação de tensão, verificar toda a conexão elétrica (cabos e conectores)
LED verde apagado	Interrupções de tensão	Assegurar uma alimentação de tensão estável sem interrupções
LED verde apagado	Sensor está com defeito	Se a alimentação de tensão estiver em ordem, substituir o sensor
LED verde aceso, sem sinal de saída na detecção de objetos	Entrada de teste (Test) não está conectada corretamente	Ver observação relativa à conexão da ET
LED amarelo intermitente	Sensor ainda está operacional, mas as condições de operação não são ideais	Verificar as condições de operação: Alinhar o feixe de luz (ponto de luz) completamente ao receptor / Limpeza das superfícies ópticas / Reajustar a sensibilidade (potenciômetro) / Se o potenciômetro

Indicador LED / padrão de erro	Causa	Medida
		estiver ajustado para a máx. sensibilidade: reduzir a distância entre o emissor e o receptor/ Verificar e, se necessário, adaptar a distância de comutação, ver tabela 27 .
LED amarelo aceso, nenhum objeto no caminho óptico	O feixe de luz de uma barreira de luz unidirecional está incidindo sobre o receptor de uma outra barreira de luz unidirecional (vizinha)	Trocar a disposição do sensor e do receptor a cada duas barreiras de luz unidirecionais ou manter distância suficiente entre as barreira de luz unidirecionais, ver figura 43 .

38 Desmontagem e descarte

O descarte do sensor deve ser efetuado de acordo com as normas aplicáveis específicas de cada país. No âmbito do descarte, deve-se procurar o aproveitamento dos materiais recicláveis contidos (principalmente dos metais nobres).

39 Manutenção

Os sensores SICK não requerem manutenção.

Recomendamos que se efetue em intervalos regulares

- uma limpeza das superfícies ópticas
- uma verificação das conexões roscadas e dos conectores

Não são permitidas modificações no aparelho.

Sujeito a alterações sem aviso prévio. As propriedades do produto e os dados técnicos especificados não constituem nenhum certificado de garantia.

40 Dados técnicos

	GRSE18(S)-xxx2xV, Infraredlight	GRSE18(S)-xxx4xV, visible red light
Distância de comutação	0 ... 10 m	0 ... 10 m
Distância de comutação máx.	0 ... 15 m	0 ... 15 m
Diâmetro do ponto de luz/distância	420 mm / 10 m	250 mm / 10 m
Tensão de alimentação U_V	DC 10 ... 30 V ²	DC 10 ... 30 V ²
Corrente de saída I_{max}	100 mA	100 mA
Sequência máx. de comutação	1,000 / s ⁵	1,000 / s ⁵
Tempo máx. de resposta	< 0,5 ms ⁶	< 0,5 ms ⁶
Tipo de proteção	IP67,IP68,IP69K ¹¹	IP67,IP68,IP69K ¹¹
Classe de proteção	III ⁸	III ⁸
Circuitos de proteção	A,B,D ¹⁰	A,B,D ¹⁰
Temperatura ambiente de funcionamento	-25 °C ... +55 °C	-25 °C ... +55 °C

- 1 Tastgut mit 90 % Remission (bezogen auf Standard-Weiß DIN 5033)
2 Grenzwerte; Betrieb im kurzschlussgeschützten Netz max. 8 A; Restwelligkeit max. 5 V_{ss}
4 Gebrauchskategorie: AC-15, DC-13 (EN 60947-1)
5 Mit Hell- / Dunkelverhältnis 1:1
6 Signallaufzeit bei ohmscher Last
7 gültig für Q\ auf Pin2, wenn per Software konfiguriert
8 Bemessungsspannung DC 50 V
10 A = U_V-Anschlüsse verpolsicher
B = Ein- und Ausgänge verpolsicher
D = Ausgänge überstrom- und kurzschlussfest
11 IP68: conforme EN 60529 (10 m profundidade da água / 24 h).
IP69K: conforme ISO 20653:2013-03.

GRSE18(S)V

Sensore fotoelettrico cilindrico

SICK
Sensor Intelligence.



de
en
es
fr
it
ja
pt
ru
zh

Descrizione prodotto

GR18 Inox
GRSE18(S)V

Produttore

SICK AG
Erwin-Sick-Str. 1
79183 Waldkirch
Germania

Luogo di produzione

SICK Malesia

Note legali

Questo manuale è protetto dai diritti d'autore. I diritti che ne conseguono rimangono alla ditta SICK. Il manuale o parti di esso possono essere fotocopiati esclusivamente entro i limiti previsti dalle disposizioni di legge in materia di diritti d'autore. Non è consentito modificare, abbreviare o tradurre il presente manuale senza previa autorizzazione scritta della ditta SICK AG.

I marchi riportati nel presente manuale sono di proprietà del rispettivo proprietario.

© SICK AG. Tutti i diritti riservati.

Documento originale

Questo documento è un originale della ditta SICK AG.



Indice

41	avvertenze di sicurezza.....	53
42	Uso conforme alle disposizioni.....	53
43	Elementi di comando e di visualizzazione.....	53
44	Montaggio.....	54
45	Installazione elettronica.....	55
46	Messa in servizio.....	58
47	Eliminazione difetti.....	59
	47.1 Tabella rimozione dei guasti.....	59
48	Smontaggio e smaltimento.....	60
49	Manutenzione.....	60
50	Dati tecnici.....	61

41 avvertenze di sicurezza

- Prima della messa in funzione leggere le istruzioni per l'uso.
-  Collegamento, montaggio e regolazione solo a cura di personale tecnico specializzato.
- Non è un componente di sicurezza ai sensi della direttiva macchine UE.
- Power supply: Class 2
Enclosure type 1
- Alla messa in funzione proteggere l'apparecchio dall'umidità e dalla sporcizia.
- Le presenti istruzioni per l'uso contengono informazioni necessarie durante il ciclo di vita del sensore.

42 Uso conforme alle disposizioni

GRSE18(S)V è un sensore fotoelettrico a sbarramento (di seguito detto sensore) utilizzato per il rilevamento ottico senza contatto di oggetti, animali e persone. Per l'esercizio sono necessari un emettitore (WS) e un ricevitore (WE). Se viene utilizzato diversamente e in caso di modifiche del prodotto, decade qualsiasi diritto alla garanzia nei confronti di SICK.

43 Elementi di comando e di visualizzazione

Tabella 29: Disegni quotati



Figura 45: Forma costruttiva corta, cavo di collegamento



Figura 46: Forma costruttiva corta, connettore maschio M12

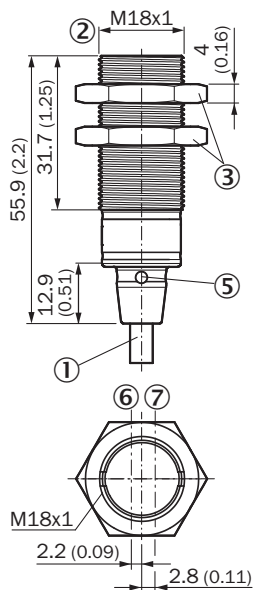

Figura 47: Forma costruttiva corta, potenziometro, cavo di collegamento

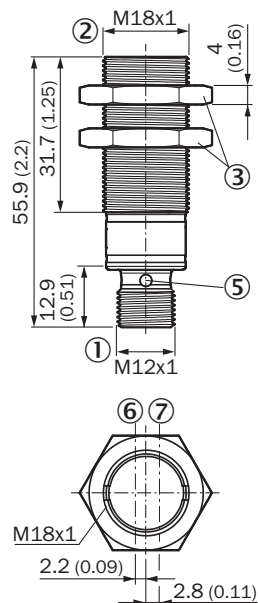

Figura 48: Forma costruttiva corta, potenziometro, connettore maschio M12

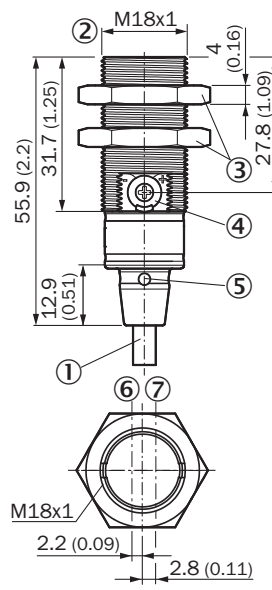

Figura 49: Forma costruttiva lunga, cavo di collegamento

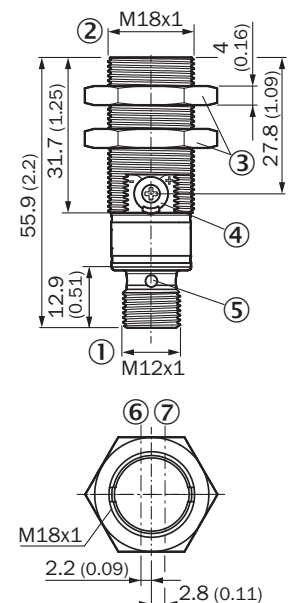

Figura 50: Forma costruttiva lunga, connettore maschio M12

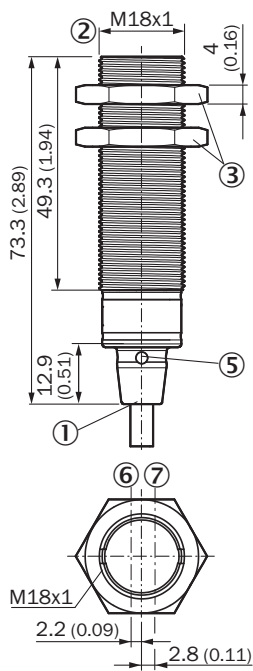

Figura 51: Forma costruttiva lunga, potenziometro, cavo di collegamento

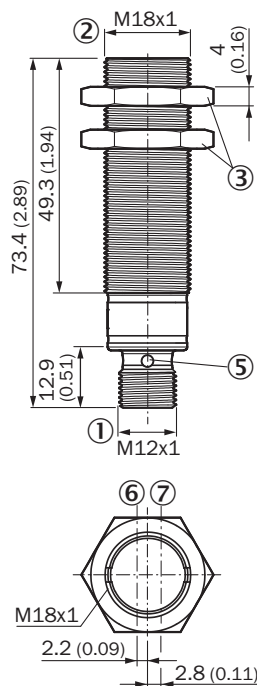

Figura 52: Forma costruttiva lunga, potenziometro, connettore maschio M12

- ① Collegamento
- ② Vite di fissaggio M18 x 1
- ③ Dado di fissaggio (2 x); WS24, acciaio inox
- ④ Potenziometro, 270°
- ⑤ Visualizzazione LED (4 x)
- ⑥ Asse ottico, ricevitore
- ⑦ Asse ottico, emettitore

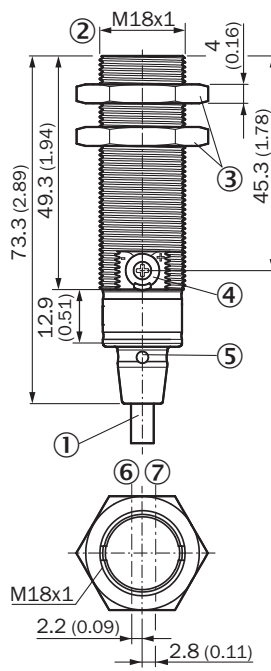

Figura 53: Comando: impostazione della sensibilità

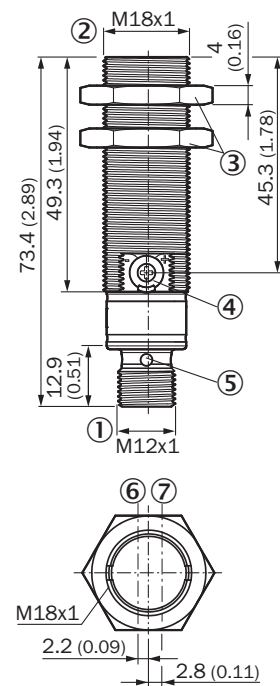
44 Montaggio

Montare i sensori (emettitore e ricevitore) sulle staffe di fissaggio adatte (vedi il programma per accessori SICK). Orientare reciprocamente l'emettitore e il rispettivo ricevitore.

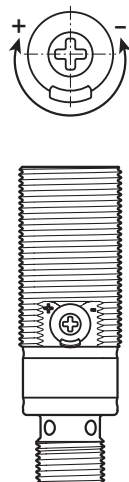
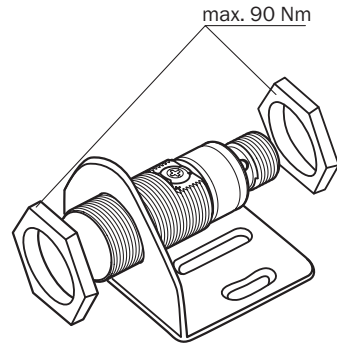

Rispettare la coppia di serraggio massima consentita del sensore di 90 Nm.



INDICAZIONE

Scambiare la disposizione di emettitore e ricevitore, o rispettare una distanza sufficiente fra i sensori fotoelettrici a sbarramento.



Figura 54: Disposizione di diversi sensori fotoelettrici a sbarramento

45 Installazione elettronica

Il collegamento dei sensori deve avvenire in assenza di tensione ($U_V = 0\text{ V}$). In base al tipo di collegamento si devono rispettare le seguenti informazioni:

- Collegamento a spina: assegnazione pin
- Cavo: colore filo

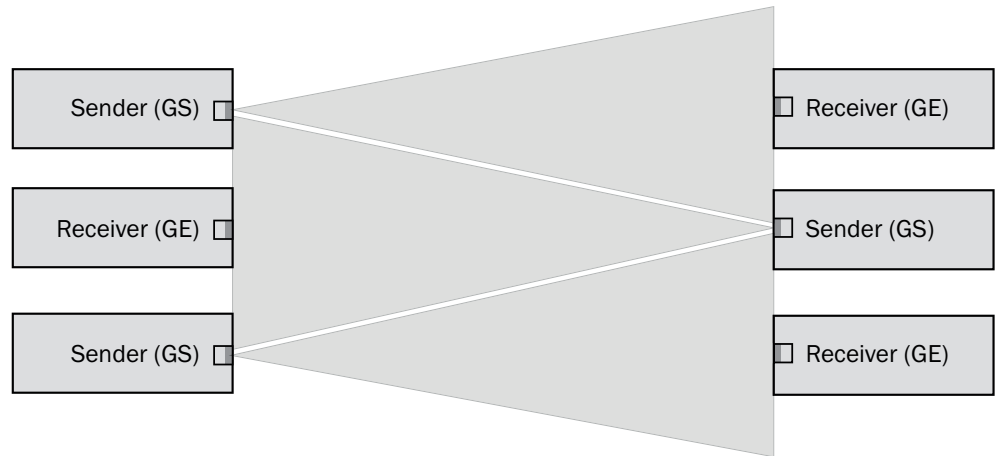
Solamente in seguito alla conclusione di tutti i collegamenti elettrici, ripristinare o accendere l'alimentazione elettrica ($U_V > 0\text{ V}$). Sul sensore si accende l'indicatore LED verde.

Spiegazioni dello schema di collegamento (Tabelle 2 e 3):

Q / \bar{Q} = uscite di commutazione

TE / Test = entrata di prova (v. tabella 33)

n. c. = non collegato

DC: 10... 30 V DC, v. „Dati tecnici“, pagina 61

Tabella 30: DC, GRS



GRS18(S)V	D11xxx	D13x2/4x	D13x1/3x	D24xxx	D23xd/4x	D23x1/3x
1	+ (L+)	+ (L+)	+ (L+)	+ (L+)	+ (L+)	+ (L+)
2	n. c.	n. c.	n. c.	n. c.	n. c.	n. c.
3	- (M)	- (M)	- (M)	- (M)	- (M)	- (M)
4	Test	Test	n. c.	Q	Test	n. c.
	 <p>1 = brn 2 = wht 3 = blu 4 = blk 0,14 mm² AWG26</p>	 <p>1 = brn 2 = wht 3 = blu 4 = blk 0,14 mm² AWG26</p>				

Tabella 31: DC, GRE

GRE18(S)V	x11xxx	x13xxx	x24xxx	x23xxx
1	+ (L+)	+ (L+)	+ (L+)	+ (L+)
2	\bar{Q}	n. c.	\bar{Q}	n. c.
3	- (M)	- (M)	- (M)	- (M)
4	Q	Q	Q	Q
	 <p>1 = brn 2 = wht 3 = blu 4 = blk 0,14 ... 1,5 mm² AWG26</p>	 <p>1 = brn - 3 = blu 4 = blk 0,14 ... 1,5 mm² AWG26</p>		

Tabella 32: DC

PNP: Q/ (≤ 100 mA)		
NPN: Q (≤ 100 mA)		
PNP: \bar{Q} (≤ 100 mA)		
NPN: \bar{Q} (≤ 100 mA)		

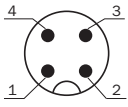
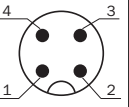
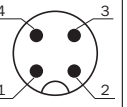
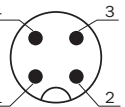
Tabella 33: Test

	Test

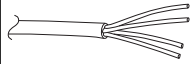
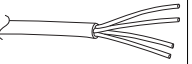
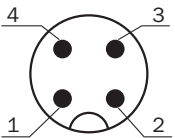
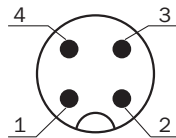
46 Messa in servizio

1 Orientamento

Orientare l'emettitore al ricevitore. Scegliere la posizione in modo tale che il raggio di luce rosso emesso colpisca il ricevitore. Suggerimento: usare della Whitepaper o il riflettore come ausilio per l'orientamento. L'emettitore deve avere una visuale libera sul ricevitore, non ci deve essere nessun oggetto nella traiettoria del raggio [v. figura]. Fare attenzione che le aperture ottiche dei sensori (frontalini) siano completamente libere.

Orientare l'emettitore al ricevitore. Scegliere la posizione in modo tale che la luce infrarossa (non visibile) colpisca il ricevitore. L'orientamento corretto può essere rilevato solo tramite l'indicatore LED. A tale proposito vedi figura e tabella 32. L'emettitore deve avere una visuale libera sul ricevitore, non ci deve essere nessun oggetto nella traiettoria del raggio. Fare attenzione che le aperture ottiche dei sensori (frontalini) siano completamente libere.



Figura: Orientamento

2 Distanza di lavoro

Rispettare le condizioni d'impiego: predisporre la distanza tra emettitore e ricevitore in base al diagramma corrispondente [v. figura 0] (x = distanza di lavoro, y = riserva operativa).

Se si impiegano diversi sensori fotoelettrici a sbarramento installati uno accanto all'altro, si consiglia di scambiare la disposizione di emettitore e ricevitore seguendo l'intervallo di ogni due sensori fotoelettrici a sbarramento, ovvero di rispettare una distanza sufficiente fra i sensori. In tal modo si possono evitare influenze reciproche [v. figura 54].

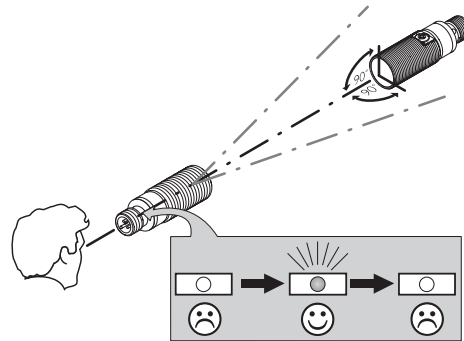
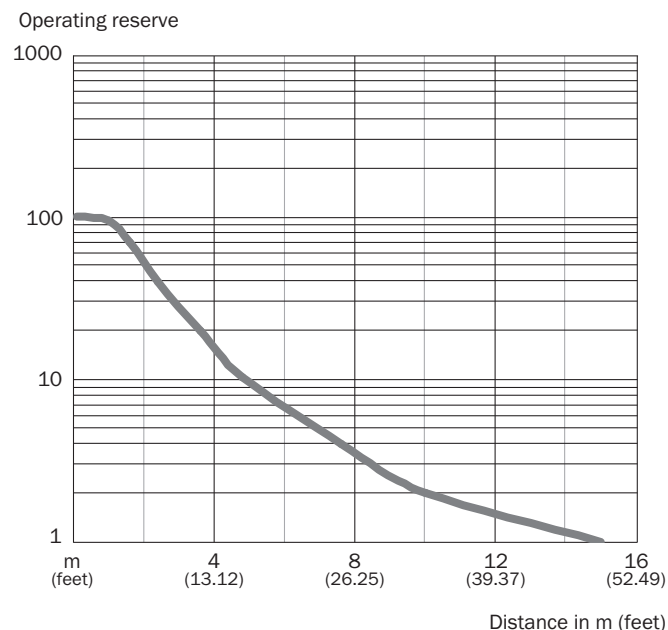

Per verificare il funzionamento, osservare e tabella 3. Se l'uscita di commutazione non si comporta conformemente alla tabella 3, verificare le condizioni d'impiego. Vedi paragrafo Diagnostica delle anomalie.



Figura 55: della distanza di lavoro

Tabella 34: Definizione distanza di lavoro

	GRSE18(S)V
①	0 ... 15 m

① Distanza di lavoro

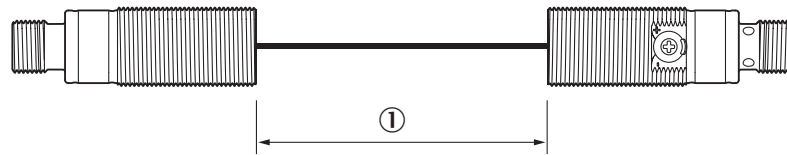
3 Regolazione della sensibilità

Sensore senza possibilità di impostazione: il sensore è impostato e pronto per il funzionamento.

Con il potenziometro (tipo: 270°) viene regolata la sensibilità. Rotazione verso destra: innalzamento della riserva operativa, rotazione verso sinistra: riduzione della riserva operativa. Si consiglia di impostare il potenziometro su "massimo".

Il sensore è impostato e pronto per il funzionamento.

4 Ingresso test

Entrata di prova: i sensori GRSE18(S)V dispongono di un'entrata di prova ("TE" o "test" nello schema di collegamento [tabella 30]), tramite la quale l'emettitore può essere disattivato e in questo modo il funzionamento regolare del sensore può venire controllato. In caso di uso di connettori femmina con indicatori LED si deve prestare attenzione che TE sia occupata nella relativa modalità.

Non ci deve essere nessun oggetto tra emettitore e ricevitore, attivare l'entrata di prova (vedi schema di collegamento [tabella 30], TE verso 0 V). Il LED di emissione si spegne, ovvero viene simulato il rilevamento di un oggetto. Per verificare il funzionamento, osservare la seguente tabella. Se l'uscita di commutazione non si comporta conformemente alla tabella seguente, verificare le condizioni d'impiego. Vedi paragrafo Diagnostica delle anomalie.

47 Eliminazione difetti

La tabella di rimozione dei disturbi mostra quali provvedimenti si devono adottare quando il sensore non funziona più.

47.1 Tabella rimozione dei guasti

Tabella 35: Eliminazione dei guasti

Indicatore LED / figura di errore	Causa	Provvedimento
Il LED verde non si accende	nessuna tensione o tensione al di sotto del valore soglia	Verificare la tensione di alimentazione e/o il collegamento elettrico
Il LED verde non si accende	Interruzioni di tensione	Assicurarsi che ci sia un'alimentazione di tensione stabile
Il LED verde non si accende	Il sensore è guasto	Se l'alimentazione di tensione è regolare, allora chiedere una sostituzione del sensore

Indicatore LED / figura di errore	Causa	Provvedimento
il LED verde si accende, nessun segnale in uscita al momento di rilevamento dell'oggetto	L'entrata di prova (Test) non è collegata correttamente	Vedi le indicazioni per il collegamento della TE
Il LED giallo lampeggia	Il sensore è ancora pronto per il funzionamento, ma le condizioni di esercizio non sono ottimali	Controllare le condizioni di esercizio: Dirigere il raggio di luce (il punto luminoso) completamente sul ricevitore / Pulizia delle superfici ottiche / Sensibilità (potenziometro) / Se il potenziometro è impostato sulla sensibilità massima: diminuire la distanza tra emettitore e ricevitore/ Controllare la distanza di lavoro e, se necessario, adattarla, v. tabella 34 .
il LED giallo si accende, nessun oggetto nella traiettoria del raggio	Il fascio di luce dell'emettitore colpisce il ricevitore di un altro relè fotoelettrico unidirezionale (vicino)	Scambiare la disposizione di emettitore e ricevitore, o rispettare una distanza sufficiente fra i sensori fotoelettrici a sbarramento, v. figura 54 .

48 Smontaggio e smaltimento

Lo smaltimento del sensore deve avvenire conformemente alle direttive previste specificatamente dal paese. Per i materiali riciclabili in esso contenuti (in particolare metalli nobili) si auspica un riciclaggio nell'ambito dello smaltimento.

49 Manutenzione

I sensori SICK sono esenti da manutenzione.

A intervalli regolari si consiglia di

- pulire le superfici limite ottiche
- Verificare i collegamenti a vite e gli innesti a spina

Non è consentito effettuare modifiche agli apparecchi.

Contenuti soggetti a modifiche senza preavviso. Le proprietà del prodotto e le schede tecniche indicate non costituiscono una dichiarazione di garanzia.

50 Dati tecnici

	GRSE18(S)-xxx2xV, Infraredlight	GRSE18(S)-xxx4xV, visible red light
Distanza di commutazione	0 ... 10 m	0 ... 10 m
Distanza max. di commutazione	0 ... 15 m	0 ... 15 m
Diametro punto luminoso/distanza	420 mm / 10 m	250 mm / 10 m
Tensione di alimentazione U_V	DC 10 ... 30 V ²	DC 10 ... 30 V ²
Corrente di uscita I_{max}	100 mA	100 mA
Sequenza di commutazione max.	1,000 / s ⁵	1,000 / s ⁵
Tempo di reazione max.	< 0,5 ms ⁶	< 0,5 ms ⁶
Tipo di protezione	IP67,IP68,IP69K ¹¹	IP67,IP68,IP69K ¹¹
Classe di protezione	III ⁸	III ⁸
Commutazioni di protezione	A,B,D ¹⁰	A,B,D ¹⁰
Temperatura ambientale di funzionamento	-25 °C ... +55 °C	-25 °C ... +55 °C

- 1 Tastgut mit 90 % Remission (bezogen auf Standard-Weiß DIN 5033)
2 Grenzwerte; Betrieb im kurzschlussgeschützten Netz max. 8 A; Restwelligkeit max. 5 V_{ss}
4 Gebrauchskategorie: AC-15, DC-13 (EN 60947-1)
5 Mit Hell- / Dunkelverhältnis 1:1
6 Signallaufzeit bei ohmscher Last
7 gültig für Q\ auf Pin2, wenn per Software konfiguriert
8 Bemessungsspannung DC 50 V
10 A = U_V-Anschlüsse verpolsicher
B = Ein- und Ausgänge verpolsicher
D = Ausgänge überstrom- und kurzschlussfest
11 IP68: secondo EN 60529 (10 m profondità dell'acqua / 24 h).
IP69K: secondo ISO 20653:2013-03.

GRSE18(S)V

Sensores fotoeléctricos cilíndricos

SICK
Sensor Intelligence.



de
en
es
fr
it
ja
pt
ru
zh

Producto descrito

GR18 Inox
GRSE18(S)V

Fabricante

SICK AG
Erwin-Sick-Str. 1
79183 Waldkirch
Alemania

Centro de producción

SICK, Malasia

Información legal

Este documento está protegido por la legislación sobre la propiedad intelectual. Los derechos derivados de ello son propiedad de SICK AG. Únicamente se permite la reproducción total o parcial de este documento dentro de los límites establecidos por las disposiciones legales sobre propiedad intelectual. Está prohibida la modificación, abreviación o traducción del documento sin la autorización expresa y por escrito de SICK AG.

Las marcas mencionadas en este documento pertenecen a sus respectivos propietarios.

© SICK AG. Reservados todos los derechos.

Documento original

Este es un documento original de SICK AG.



Índice

51	Indicaciones de seguridad.....	65
52	Uso conforme a lo previsto.....	65
53	Elementos de mando y visualización.....	65
54	Montaje.....	66
55	Instalación electrónica.....	67
56	Puesta en servicio.....	70
57	Resolución de problemas.....	71
	57.1 Tabla de solución de problemas.....	71
58	Desmontaje y eliminación.....	72
59	Mantenimiento.....	72
60	Datos técnicos.....	73

51 Indicaciones de seguridad

- Lea las instrucciones de uso antes de efectuar la puesta en servicio.
-  La conexión, el montaje y el ajuste deben efectuarlos exclusivamente técnicos especialistas.
- No se trata de un componente de seguridad según la Directiva de máquinas de la UE.
- Power supply: Class 2
Enclosure type 1
- Proteja el dispositivo contra la humedad y la suciedad durante la puesta en servicio.
- Las presentes instrucciones de uso contienen información que puede serle necesaria durante todo el ciclo de vida del sensor.

52 Uso conforme a lo previsto

La GRSE18(S)V es una barrera emisor-receptor optoelectrónica (en lo sucesivo llamada sensor) empleada para la detección óptica y sin contacto de objetos, animales y personas. Para que funcione se precisa un emisor (WS) y un receptor (WE). Cualquier uso diferente al previsto o modificación en el producto invalidará la garantía por parte de SICK AG.

53 Elementos de mando y visualización

Tabla 36: Dibujos acotados



Figura 56: Diseño corto, cable de conexión



Figura 57: Diseño corto, conector macho M12

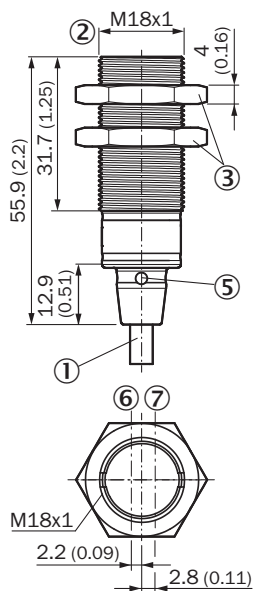

Figura 58: Diseño corto, potenciómetro, cable de conexión

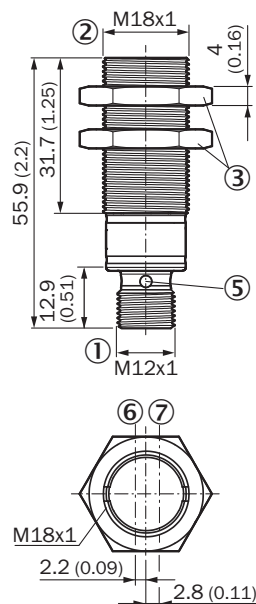

Figura 59: Diseño corto, potenciómetro, conector macho M12

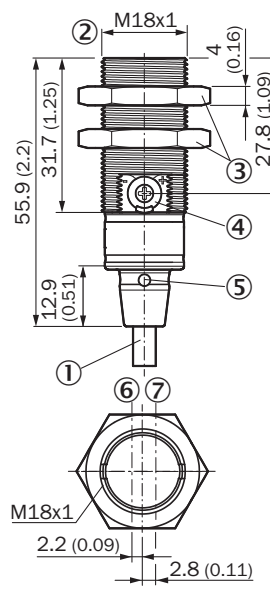

Figura 60: Diseño largo, cable de conexión

Figura 61: Diseño largo, conector macho M12

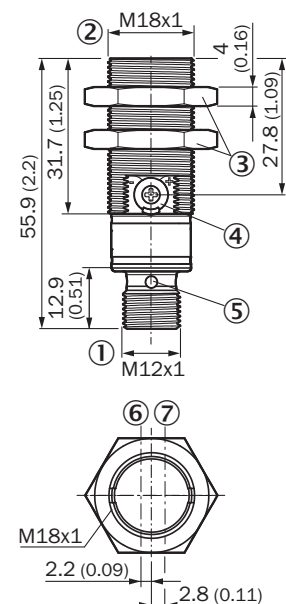
Figura 62: Diseño largo, potenciómetro, cable de conexión

Figura 63: Diseño largo, potenciómetro, conector macho M12

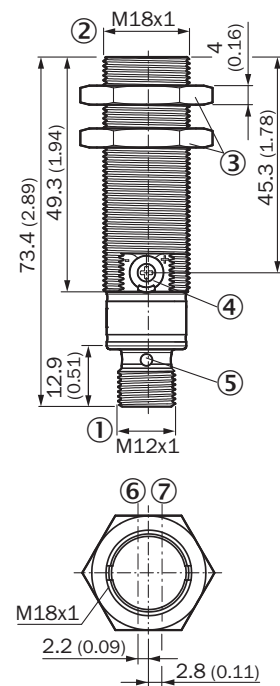
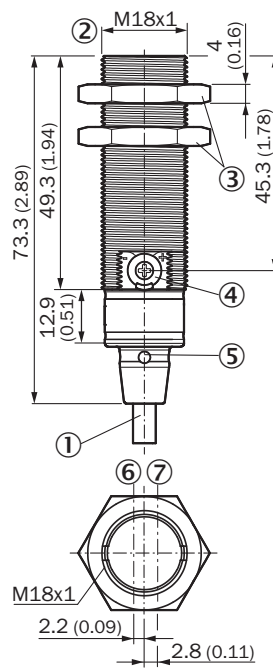
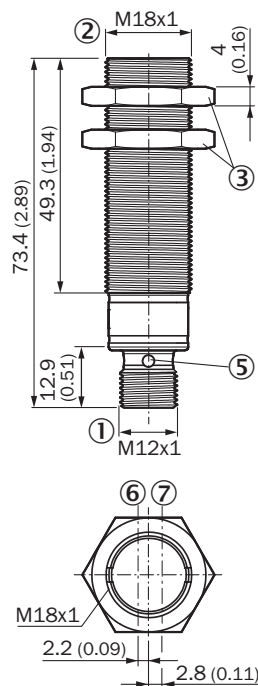
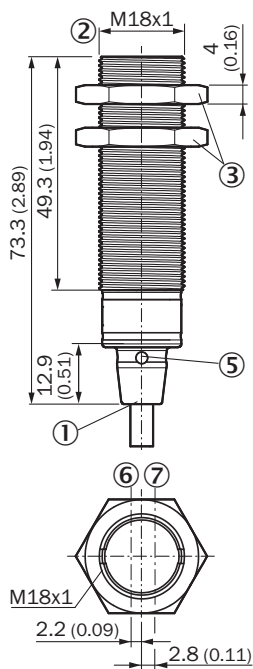
- ① Conexión
- ② Rosca de fijación M18 x 1
- ③ Tuerca de fijación (2 x); WS24, acero inoxidable
- ④ Potenciómetro, 270°
- ⑤ Pantalla LED (4 x)
- ⑥ Eje óptico del receptor
- ⑦ Eje óptico del emisor



Figura 64: Elemento de control: Ajuste de sensibilidad

54 Montaje

Montar los sensores (emisor y receptor) en escuadras de fijación adecuadas (véase el programa de accesorios SICK). Alinear el emisor y el receptor entre sí.

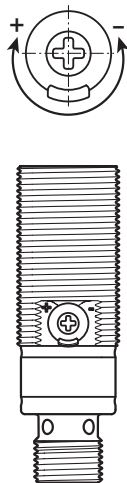
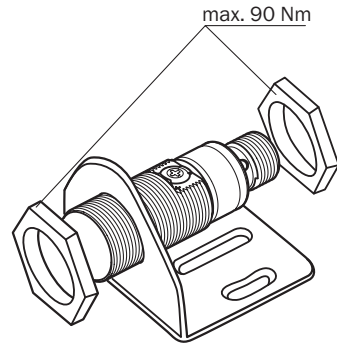

Respetar el par de apriete máximo admisible del sensor de 90 Nm.



INDICACIÓN

Cada dos barreras emisor-receptor, cambiar la disposición de transmisores y receptores o mantener una distancia suficiente entre ellas.



Figura 65: Disposición de varias barreras emisor-receptor

55 Instalación electrónica

Los sensores deben conectarse sin tensión ($V_s = 0\text{ V}$). Debe tenerse en cuenta la siguiente información en función de cada tipo de conexión:

- Conexión de enchufes: asignación de terminales
- Cable: color del hilo

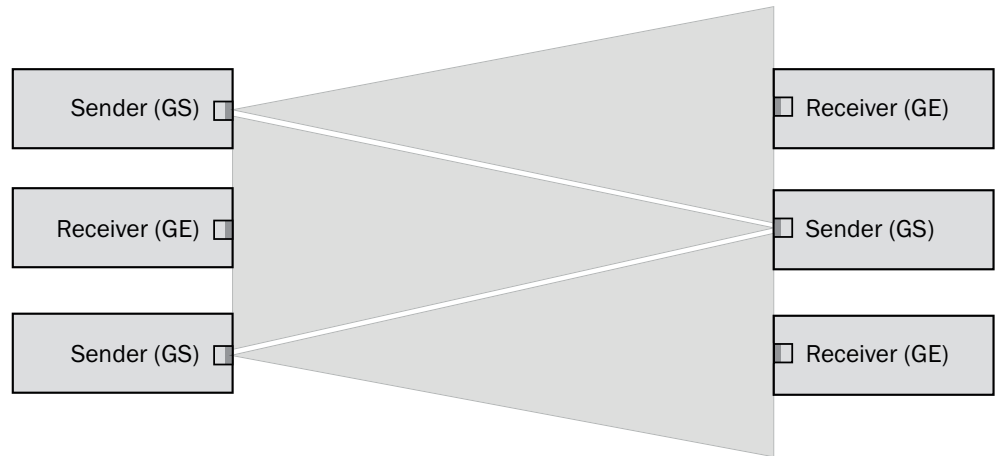
No aplicar o conectar la fuente de alimentación ($V_s > 0\text{ V}$) hasta que no se hayan finalizado todas las conexiones eléctricas. En el sensor se ilumina el LED indicador verde.

Explicaciones relativas al esquema de conexión (tablas 2 y 3):

Q / \bar{Q} = salidas conmutadas

TE / Test = entrada de prueba (véase tabla 40)

n. c. = no conectado

CC: 10 ... 30 V CC, véase „Datos técnicos“, página 73

Tabla 37: CC, GRS



GRS18(S)V	D11xxx	D13x2/4x	D13x1/3x	D24xxx	D23xd/4x	D23x1/3x
1	+ (L+)	+ (L+)	+ (L+)	+ (L+)	+ (L+)	+ (L+)
2	n. c.	n. c.	n. c.	n. c.	n. c.	n. c.
3	- (M)	- (M)	- (M)	- (M)	- (M)	- (M)
4	Prueba	Prueba	n. c.	Q	Prueba	n. c.
	 1 = brn (marrón) 2 = wht (blanco) 3 = blu (azul) 4 = blk (negro) 0,14 mm ² AWG26	 1 = brn (marrón) 2 = wht (blanco) 3 = blu (azul) 4 = blk (negro) 0,14 mm ² AWG26				

Tabla 38: CC, GRE

GRE18(S)V	x11xxx	x13xxx	x24xxx	x23xxx
1	+ (L+)	+ (L+)	+ (L+)	+ (L+)
2	\bar{Q}	n. c.	\bar{Q}	n. c.
3	- (M)	- (M)	- (M)	- (M)
4	Q	Q	Q	Q
	 1 = brn (marrón) 2 = wht (blanco) 3 = blu (azul) 4 = blk (negro) 0,14 ... 1,5 mm ² AWG26	 1 = brn (marrón) - 3 = blu (azul) 4 = blk (negro) 0,14 ... 1,5 mm ² AWG26		

Tabla 39: CC

PNP: Q (≤ 100 mA)		
NPN: Q (≤ 100 mA)		
PNP: \bar{Q} (≤ 100 mA)		
NPN: \bar{Q} (≤ 100 mA)		

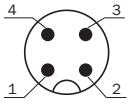
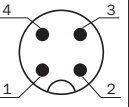
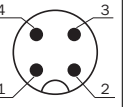
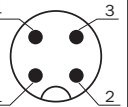
Tabla 40: Prueba

	Prueba

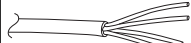
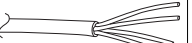
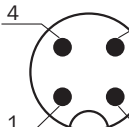
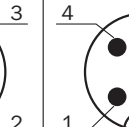
56 Puesta en servicio

1 Alineación

Oriente el emisor hacia el receptor. Seleccione una posición que permita que el haz de luz roja del emisor incida en el receptor. Recomendación: utilizar papel blanco o un reflector como ayuda de alineación. El emisor debe tener una visión despejada del receptor, no puede haber ningún objeto en la trayectoria del haz [véase figura]. Hay que procurar que las aperturas ópticas (pantallas frontales) de los sensores estén completamente libres. Oriente el emisor hacia el receptor. Seleccione una posición que permita que la luz infrarroja (no visible) incida en el receptor. La alineación correcta solo se puede detectar mediante los LED indicadores. Véase a este respecto figura y tabla 39. El emisor debe tener una visión despejada del receptor, no puede haber ningún objeto en la trayectoria del haz. Hay que procurar que las aperturas ópticas (pantallas frontales) de los sensores estén completamente libres.



Figura: Alineación

2 Distancia de conmutación

Respetar las condiciones de aplicación: comparar la distancia entre el emisor y el receptor con el diagrama correspondiente [véase figura 0] (x = distancia de conmutación, y = reserva de funcionamiento).

Si se usan varias barreras emisor-receptor una al lado de otra, recomendamos cambiar la disposición de emisores y receptores cada dos barreras, o mantener una distancia suficiente entre ellas. De este modo se evitarán las interferencias mutuas [véase figura 65].

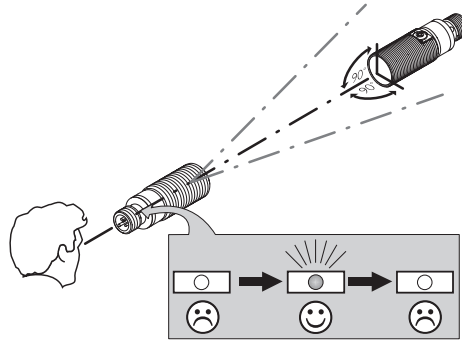
Operating reserve

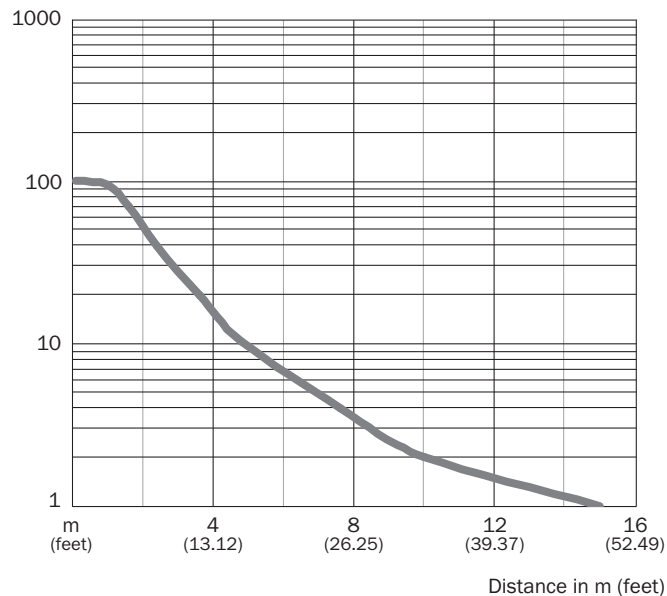

Para verificar el funcionamiento, véanse y la tabla 3. Si la salida conmutada no se comporta según la tabla 3, comprobar las condiciones de aplicación. Véase la sección “Diagnóstico de fallos”.



Figura 66: distancia de conmutación

Tabla 41: Definición de distancia de conmutación

	GRSE18(S)V
①	0 ... 15 m

① Distancia de conmutación

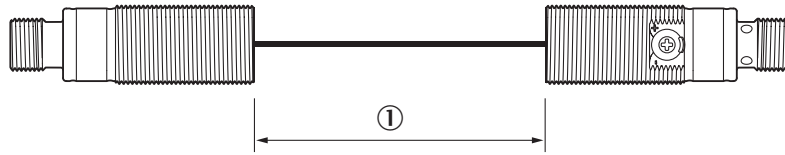
3 Ajuste de la sensibilidad

Sensor sin posibilidad de ajuste: el sensor está ajustado y listo para su uso.

Con el potenciómetro (tipo: 270°) se ajusta la sensibilidad. Giro hacia la derecha: aumenta la reserva de funcionamiento; giro hacia la izquierda: se reduce la reserva de funcionamiento. Recomendamos poner el potenciómetro a su nivel “máximo”.

El sensor está ajustado y listo para su uso.

4 Entrada de prueba

Entrada de prueba: los sensores GRSE18(S)V disponen de una entrada de prueba (“TE” o “Test” en el esquema de conexión [tabla 37]), con la que puede desconectarse el emisor y, de ese modo, comprobarse el buen funcionamiento del sensor: si se utilizan tomas de red con indicadores LED hay que procurar que la TE esté asignada como corresponde.

No debe haber ningún objeto entre emisor y receptor; activar la entrada de prueba (véase el esquema de conexión [tabla 37], TE tras 0 V). El LED emisor se desconecta o se simula que se ha detectado un objeto. Para verificar el funcionamiento, véase la tabla siguiente. Si la salida conmutada no se comporta según la tabla siguiente, comprobar las condiciones de aplicación. Véase la sección “Diagnóstico de fallos”.

57 Resolución de problemas

La tabla “Resolución de problemas” muestra las medidas que hay que tomar cuando ya no está indicado el funcionamiento del sensor.

57.1 Tabla de solución de problemas

Tabla 42: Resolución de problemas

LED indicador / imagen de error	Causa	Acción
El LED verde no se ilumina	Sin tensión o tensión por debajo de los valores límite	Comprobar la fuente de alimentación, comprobar toda la conexión eléctrica (cables y conectores)
El LED verde no se ilumina	Interrupciones de tensión	Asegurar una fuente de alimentación estable sin interrupciones de tensión
El LED verde no se ilumina	El sensor está defectuoso	Si la fuente de alimentación no tiene problemas, cambiar el sensor
El LED verde se ilumina, no hay señal de salida cuando se detecta un objeto	La entrada de prueba (Test) no está correctamente conectada	Ver indicaciones para conectar la entrada de prueba (TE)

LED indicador / imagen de error	Causa	Acción
El LED amarillo parpadea	El sensor aún está operativo, pero las condiciones de servicio no son óptimas	Comprobar las condiciones de servicio: Alinear el haz de luz (spot) completamente con el receptor / Limpieza de las superficies ópticas / Reajustar la sensibilidad (potenciómetro) / Si el potenciómetro está ajustado a la máxima sensibilidad, reducir la distancia entre el emisor y el receptor/ Comprobar la distancia de conmutación y, si es necesario, adaptarla, véase tabla 41 .
El LED amarillo se ilumina, no hay ningún objeto en la trayectoria del haz	El haz de luz de una barrera fotoeléctrica monohaz incide sobre el receptor de otra barrera fotoeléctrica monohaz (vecina)	Cada dos barreras emisor-receptor, cambiar la disposición de emisores y receptores o mantener una distancia suficiente entre ellas, véase figura 65 .

58 Desmontaje y eliminación

El sensor tiene que eliminarse siguiendo la normativa aplicable específica de cada país. Los materiales valiosos que contenga (especialmente metales nobles) deben ser eliminados considerando la opción del reciclaje.

59 Mantenimiento

Los sensores SICK no precisan mantenimiento.

A intervalos regulares, recomendamos:

- Limpiar las superficies ópticas externas
- Comprobar las uniones roscadas y las conexiones.

No se permite realizar modificaciones en los aparatos.

Sujeto a cambio sin previo aviso. Las propiedades y los datos técnicos del producto no suponen ninguna declaración de garantía.

60 Datos técnicos

	GRSE18(S)-xxx2xV, Infraredlight	GRSE18(S)-xxx4xV, visible red light
Distancia de conmutación	0 ... 10 m	0 ... 10 m
Distancia de conmutación máx.	0 ... 15 m	0 ... 15 m
Diámetro del punto luminoso/distancia	420 mm / 10 m	250 mm / 10 m
Tensión de alimentación U_V	DC 10 ... 30 V ²	DC 10 ... 30 V ²
Intensidad de salida I_{max} .	100 mA	100 mA
Secuencia de conmutación máx.	1,000 / s ⁵	1,000 / s ⁵
Tiempo de respuesta máx.	< 0,5 ms ⁶	< 0,5 ms ⁶
Tipo de protección	IP67,IP68,IP69K ¹¹	IP67,IP68,IP69K ¹¹
Clase de protección	III ⁸	III ⁸
Circuitos de protección	A,B,D ¹⁰	A,B,D ¹⁰
Temperatura ambiente de servicio	-25 °C ... +55 °C	-25 °C ... +55 °C

1 Tastgut mit 90 % Remission (bezogen auf Standard-Weiß DIN 5033)

2 Grenzwerte; Betrieb im kurzschlussgeschützten Netz max. 8 A; Restwelligkeit max. 5 V_{ss}

4 Gebrauchskategorie: AC-15, DC-13 (EN 60947-1)

5 Mit Hell- / Dunkelverhältnis 1:1

6 Signallaufzeit bei ohmscher Last

7 gültig für Q\ auf Pin2, wenn per Software konfiguriert

8 Bemessungsspannung DC 50 V

10 A = U_V-Anschlüsse verpolsicher

B = Ein- und Ausgänge verpolsicher

D = Ausgänge überstrom- und kurzschlussfest

11 IP68: conforme a EN 60529 (10 m de profundidad en el agua / 24 h).

IP69K: conforme a ISO 20653:2013-03.

GRSE18(S)V

圆柱形光电传感器

SICK
Sensor Intelligence.



de
en
es
fr
it
ja
pt
ru
zh

所说明的产品

GR18 Inox
GRSE18(S)V

制造商

SICK AG
Erwin-Sick-Str. 1
79183 Waldkirch, Germany
德国

生产基地

SICK, 马来西亚

法律信息

本文档受版权保护。其中涉及到的一切权利归西克公司所有。只允许在版权法的范围内复制本文档的全部或部分內容。未经西克公司的明确书面许可，不允许对文档进行修改、删减或翻译。

本文档所提及的商标为其各自所有者的资产。

© 西克公司版权所有。版权所有

原始文档

本文档为西克股份公司的原始文档。



内容

61	安全须知.....	77
62	规定用途.....	77
63	操作及显示元件.....	77
64	安装.....	78
65	电子安装.....	79
66	调试.....	82
67	故障排除.....	83
	67.1 故障排除表格.....	83
68	拆卸和废弃处理.....	84
69	保养.....	84
70	技术参数.....	85

61 安全须知

- 调试前请阅读操作指南。
-  仅允许由专业人员进行接线、安装和设置。
- 非欧盟机械指令中定义的安全部件。
- Power supply: Class 2
Enclosure type 1
- 调试设备时应防潮防污染。
- 本操作指南中包含了传感器生命周期中必需的各项信息。

62 规定用途

GRSE18(S)V 是一种对射式光电传感器（下文简称为“传感器”），用于物体、动物和人体的非接触式光学检测。须配有一个发射器 (WS) 和一个接收器 (WE) 才可正常运行。如滥用本产品或擅自对其进行改装，则 SICK 公司的所有质保承诺均将失效。

63 操作及显示元件

表格 43: 尺寸图



插图 67: 短构型, 连接电缆

插图 68: 短构型, M12 插头

插图 69: 短构型, 电位计, 连接电缆

插图 70: 短构型, 电位计, M12 插头

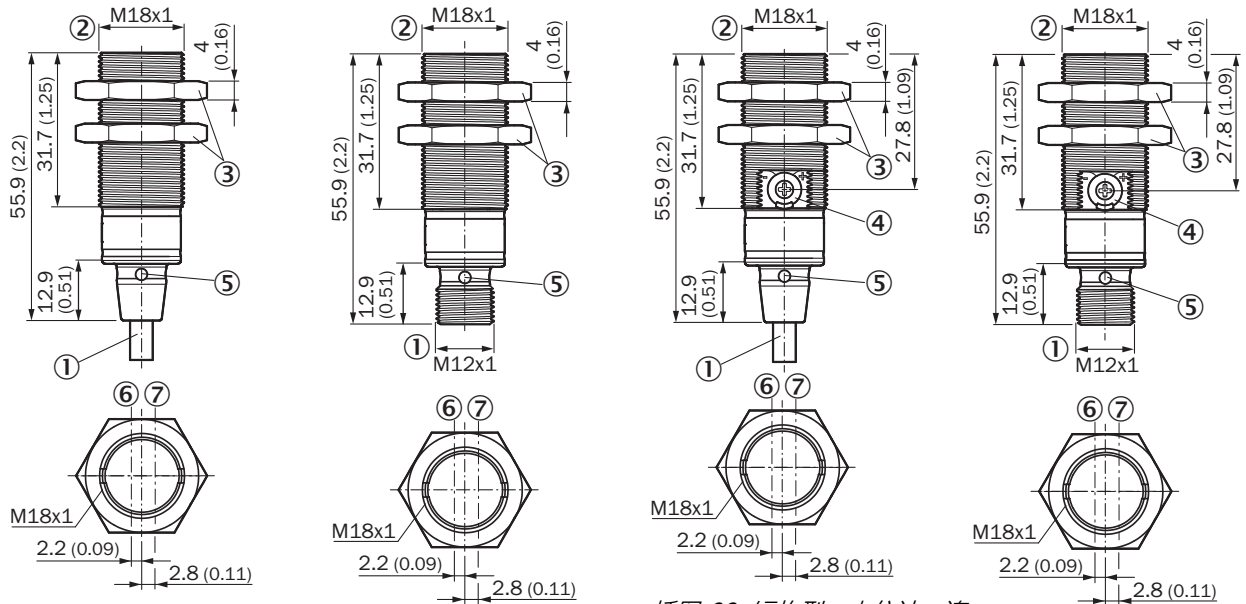

插图 71: 长构型, 连接电缆



插图 72: 长构型, M12 插头

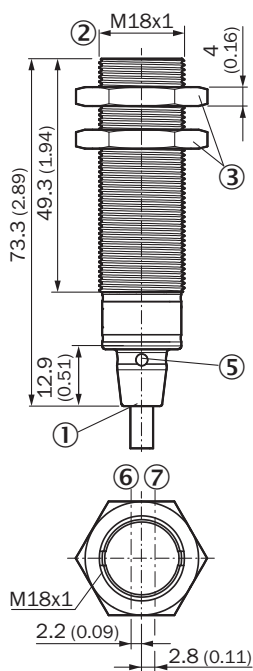

插图 73: 长构型, 电位计, 连接电缆

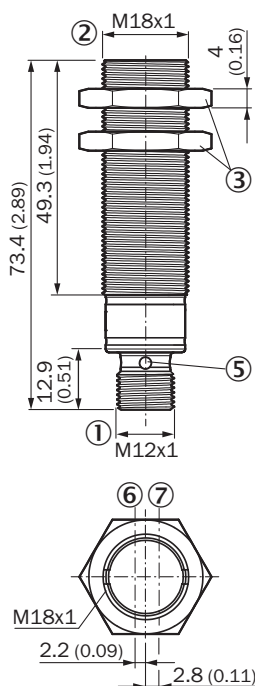

插图 74: 长构型, 电位计, M12 插头

- ① 接口
- ② 安装螺纹 M18 x 1
- ③ 固定螺母 (2 x); WS24, 不锈钢
- ④ 电位计, 270°
- ⑤ LED 指示灯 (4 x)
- ⑥ 光轴, 接收器
- ⑦ 光轴, 发射器

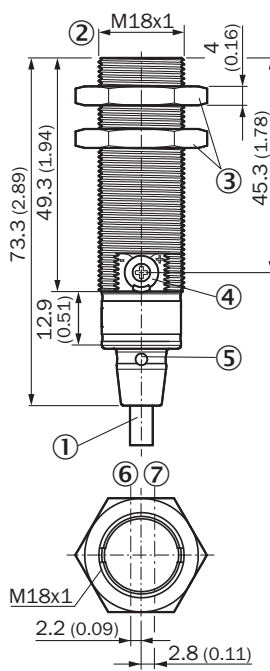

插图 75: 操作元件: 灵敏度调节

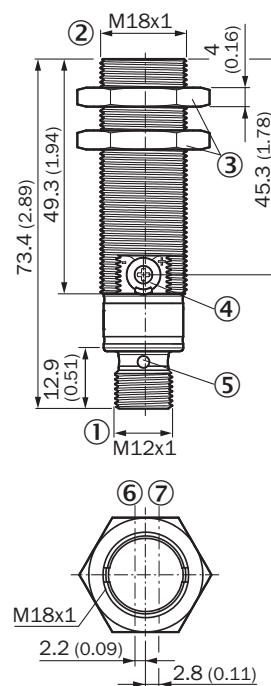
64 安装

将传感器（发射器和接收器）安装在合适的安装支架上（参见 SICK 配件目录）。相互对准反射器和接收器。

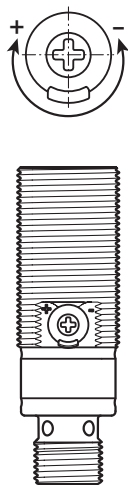
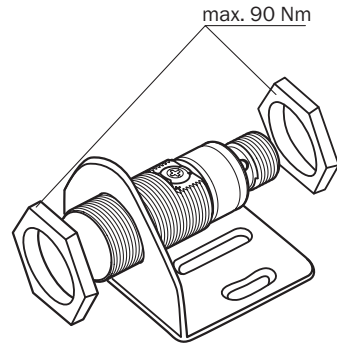

注意传感器的最大允许拧紧扭矩为 90 Nm。



提示

每隔一个单向光栅即交换发射器和接收器的顺序或在各个单向光栅之间保留足够间距。



插图 76: 多个对射式光电传感器的顺序

65 电子安装

必须在无电压状态 ($U_V = 0\text{ V}$) 连接传感器。依据不同连接类型, 注意下列信息:

- 插头连接: 引线分配
- 电缆: 芯线颜色

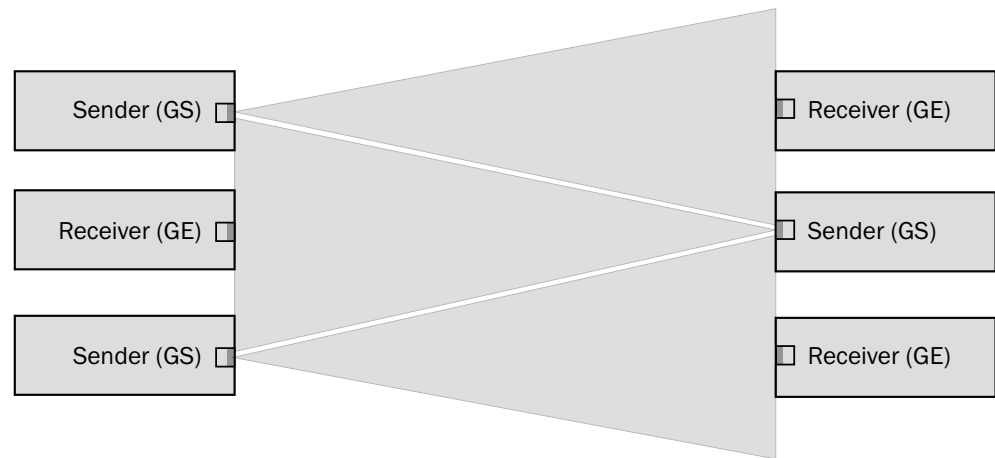
完成所有电气连接后, 才可施加或接通电压供给 ($U_V > 0\text{ V}$)。传感器上的绿色 LED 指示灯亮起。

接线图 (表格 2 和 3) 说明:



Q / \bar{Q} = 开关量输出

TE / Test = 测试输入端 (参见 表格 47)

n. c. = 未连接

DC: 10... 30 V DC, 参见 „技术参数“, 第 85 页

表格 44: DC, GRS

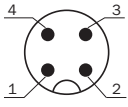
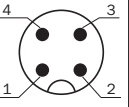
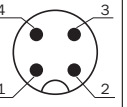
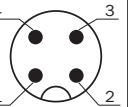
GRS18(S)V	D11xxx	D13x2/4x	D13x1/3x	D24xxx	D23xd/4x	D23x1/3x
1	+ (L+)	+ (L+)	+ (L+)	+ (L+)	+ (L+)	+ (L+)
2	n. c.	n. c.	n. c.	n. c.	n. c.	n. c.
3	- (M)	- (M)	- (M)	- (M)	- (M)	- (M)
4	测试	测试	n. c.	Q	测试	n. c.
	 <p>1 = brn (棕) 2 = wht (白) 3 = blu (蓝) 4 = blk (黑) 0.14 mm² AWG26</p>	 <p>1 = brn (棕) 2 = wht (白) 3 = blu (蓝) 4 = blk (黑) 0.14 mm² AWG26</p>				

表格 45: DC, GRE

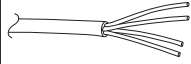
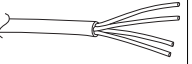
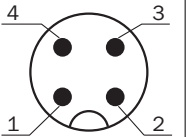
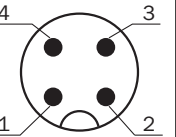
GRE18(S)V	x11xxx	x13xxx	x24xxx	x23xxx
1	+ (L+)	+ (L+)	+ (L+)	+ (L+)
2	\bar{Q}	n. c.	\bar{Q}	n. c.
3	- (M)	- (M)	- (M)	- (M)
4	Q	Q	Q	Q
	 <p>1 = brn (棕) 2 = wht (白) 3 = blu (蓝) 4 = blk (黑) 0.14 ... 1.5 mm² AWG26</p>	 <p>1 = brn (棕) - 3 = blu (蓝) 4 = blk (黑) 0.14 ... 1.5 mm² AWG26</p>		

表格 46: DC

PNP: Q (≤ 100 mA)		
NPN: Q (≤ 100 mA)		
PNP: \bar{Q} (≤ 100 mA)		
NPN: \bar{Q} (≤ 100 mA)		

表格 47: 测试

	测试

66 调试

1 校准

将发射器对准接收器。选择定位，确保红色发射光束射中接收器。提示：可使用白纸或反射器作为校准参考。发射器应无遮挡地观察到接收器，光路中不得有任何物体 [参见插图]。此时，应注意传感器的光学开口（透明保护盖）处应无任何遮挡。

将发射器对准接收器。选择定位，确保红外光（不可见光）射中接收器。仅可通过 LED 指示灯辨别校准是否正确。为此，请参见插图和表格 46。发射器应无遮挡地观察到接收器，光路中不得有任何物体。此时，应注意传感器的光学开口（透明保护盖）处应无任何遮挡。



插图: 校准

2 触发感应距离

注意使用条件：根据相关图表 [参见插图 0] 调整发射器和接收器之间的距离 (x = 触发感应距离, y = 运行备用)。

使用多个采用相邻方式安装的对射式光电传感器时，我们建议每隔一个对射式光电传感器即交换发射器和接收器的顺序或按规定在各个对射式光电传感器之间保留足够间距。由此可避免相互干扰 [参见插图 76]。

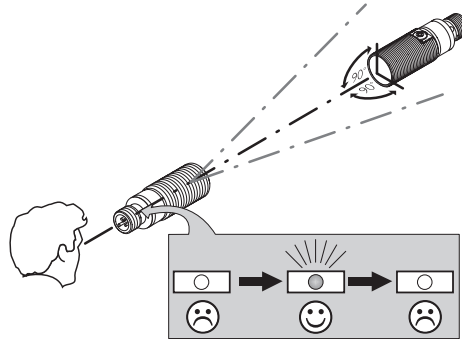
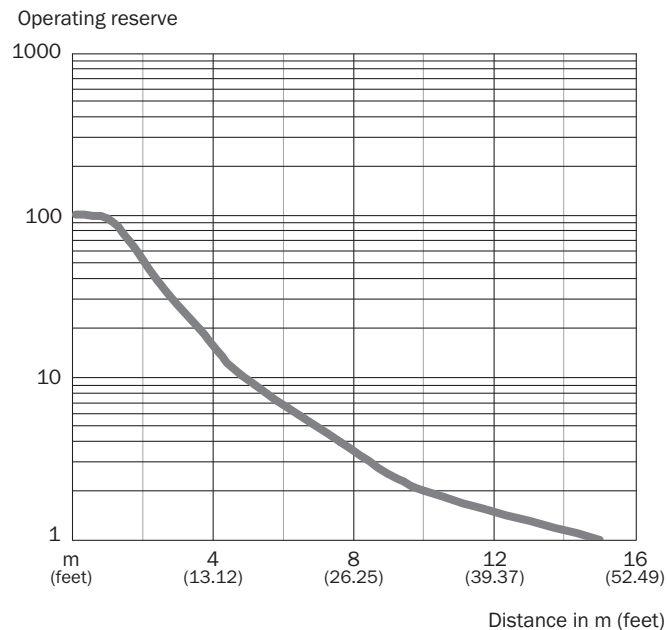

参照 和表格 3 检查功能。如果开关量输出的表现不符合表格 3，则须检查使用条件。参见故障诊断章节。



插图 77: 触发感应距离

表格 48: 触发感应距离定义

	GRSE18(S)V
①	0 ... 15 m

① 触发感应距离

3 设置灵敏度

无需设置传感器：传感器已设置并准备就绪。

使用电位计（型号：270°）设置灵敏度。向右旋转：提高运行备用，向左旋转：降低运行备用。我们建议将电位计调为“最大”。

传感器已设置并准备就绪。

4 测试输入端

测试输入端：传感器 GRSE18(S)V 具有一个测试输出端（接线图 [表格 44] 中的“TE”或者“Test”），使用该输入端关闭发射器及检查传感器功能是否正确：使用配备 LED 指示灯的电缆插口时应注意相应分配 TE。

激活测试输入端时，发送器和接收器之间不得出现任何物体（参见接线图 [表格 44]，TE 为 0 V）。发送 LED 关闭或者模拟检测到物体。参照以下表格检查功能。如果开关量输出的表现不符合以下表格，则须检查使用条件。参见故障诊断章节。

67 故障排除

故障排除表格中罗列了传感器无法执行某项功能时应采取的各项措施。

67.1 故障排除表格

表格 49: 故障排除

LED 指示灯 / 故障界面	原因	措施
绿色 LED 未亮起	无电压或电压低于极限值	检查电源，检查整体电气连接（导线和插头连接）
绿色 LED 未亮起	电压中断	确保电源稳定无中断
绿色 LED 未亮起	传感器损坏	如果电源正常，则更换传感器
绿色 LED 亮起，探测物体时无输出信号	未正确连接测试输入端 (Test)	参见 TE 的连接提示
，黄色 LED 闪烁	尽管传感器准备就绪，但运行条件不佳	检查运行条件：光束（光斑）完全对准接收器 / 清洁光学表面 / 重新设置灵敏度（电位计） / 如果已将电位计设置到最大灵敏度：减小发射器和接收器之间的间距 / 检查触发感应距离，必要时调整，参见表格 48。
黄色 LED 亮起，光路中无物体	某个单向光栅的光束照射到另一个（相邻）单向光栅的接收器上	每隔一个对射式光电传感器即交换发射器和接收器的顺序或在各个对射式光电传感器之间保留足够间距，参见插图 76。

68 拆卸和废弃处理

必须根据当地特定的法律法规废弃处理传感器。如果其中含有可回收材料（尤其是贵金属），则必须在废弃处理时回收利用。

69 保养

SICK 传感器无需保养。

我们建议，定期：

- 清洁镜头检测面
- 检查螺栓连接和插头连接

不得对设备进行任何改装。

如有更改,不另行通知。所给出的产品特性和技术参数并非质保声明。

70 技术参数

	GRSE18(S)-xxx2xV, Infraredlight	GRSE18(S)-xxx4xV, visible red light
开关距离	0 ... 10 m	0 ... 10 m
最大开关距离	0 ... 15 m	0 ... 15 m
光斑直径/距离	420 mm / 10 m	250 mm / 10 m
供电电压 U_V	DC 10 ... 30 V ²	DC 10 ... 30 V ²
输出电流 I_{max}	100 mA	100 mA
最大开关操作顺序	1,000 / s ⁵	1,000 / s ⁵
最长响应时间	< 0,5 ms ⁶	< 0,5 ms ⁶
防护类型	IP67,IP68,IP69K ¹¹	IP67,IP68,IP69K ¹¹
防护等级	III ⁸	III ⁸
保护电路	A,B,D ¹⁰	A,B,D ¹⁰
工作环境温度	-25 °C ... +55 °C	-25 °C ... +55 °C

¹ Tastgut mit 90 % Remission (bezogen auf Standard-Weiß DIN 5033)

² Grenzwerte; Betrieb im kurzschlussgeschützten Netz max. 8 A; Restwelligkeit max. 5 V_{ss}

⁴ Gebrauchskategorie: AC-15, DC-13 (EN 60947-1)

⁵ Mit Hell- / Dunkelverhältnis 1:1

⁶ Signallaufzeit bei ohmscher Last

⁷ gültig für Q\ auf Pin2, wenn per Software konfiguriert

⁸ Bemessungsspannung DC 50 V

¹⁰ A = U_V-Anschlüsse verpolsicher

B = Ein- und Ausgänge verpolsicher

D = Ausgänge überstrom- und kurzschlussfest

¹¹ IP68: 根据 EN 60529 (10 m 水深 / 24 h)。

IP69K: 根据 ISO 20653: 2013-03。

GRSE18(S)V

シリンダ型光電センサ

SICK
Sensor Intelligence.



de
en
es
fr
it
ja
pt
ru
zh

説明されている製品

GR18 Inox
GRSE18(S)V

メーカー

SICK AG
Erwin-Sick-Str. 1
79183 Waldkirch
Germany

生産拠点

SICK、マレーシア

法律情報

本書は著作権によって保護されています。著作権に由来するいかなる権利も SICK AG が保有しています。本書および本書の一部の複製は、著作権法の法的規定の範囲内でのみ許可されます。本書の内容を変更、削除または翻訳することは、SICK AG の書面による明確な同意がない限り禁じられています。

本書に記載されている商標は、それぞれの所有者の所有です。

© SICK AG. 無断複写・複製・転載を禁ず。

オリジナルドキュメント

このドキュメントは SICK AG のオリジナルドキュメントです。



コンテンツ

71	安全上の注意事項.....	89
72	正しいご使用方法.....	89
73	操作/表示要素.....	89
74	取付.....	90
75	電子装備.....	91
76	コミッショニング.....	94
77	トラブルシューティング.....	95
	77.1 トラブルシューティング表.....	95
78	解体および廃棄.....	96
79	メンテナンス.....	96
80	技術仕様.....	97

71 安全上の注意事項

- コミッショニング前に取扱説明書をお読みください。
-  接続、取付けおよび設定できるのは専門技術者に限ります。
- 本製品は EU 機械指令の要件を満たす安全コンポーネントではありません。
- Power supply: Class 2
Enclosure type 1
- コミッショニングの際には、装置が濡れたり汚れたりしないように保護してください。
- 本取扱説明書には、センサのライフサイクル中に必要となる情報が記載されています。

72 正しいご使用方法

GRSE18(S)V とは透過形光電スイッチ (以下センサと呼ぶ) で、物体、動物または人物などを光学技術により非接触で検知するための装置です。動作には投光器 (WS) および受光器 (WE) が必要です。製品を用途以外の目的で使用したり改造したりした場合は、SICK AG に対する一切の保証請求権が無効になります。

73 操作/表示要素

表 50: 寸法図面



図 78: ショート形状、接続ケーブル

図 79: ショート形状、M12 オスコネクタ

図 80: ショート形状、ポテンシオメータ、接続ケーブル

図 81: ショート形状、ポテンシオメータ、M12 オスコネクタ

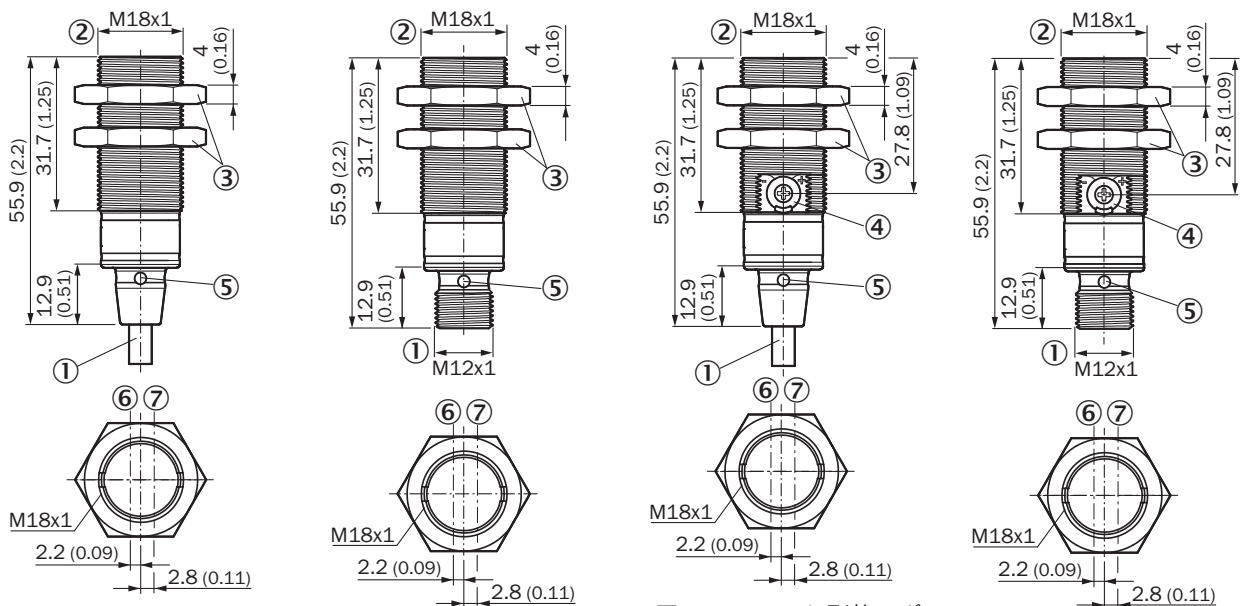

図 82: ロング形状、接続ケーブル

図 83: ロング形状、M12 オスコネクタ

図 84: ロング形状、ポテンシヨメータ、接続ケーブル

図 85: ロング形状、ポテンシヨメータ、M12 オスコネクタ

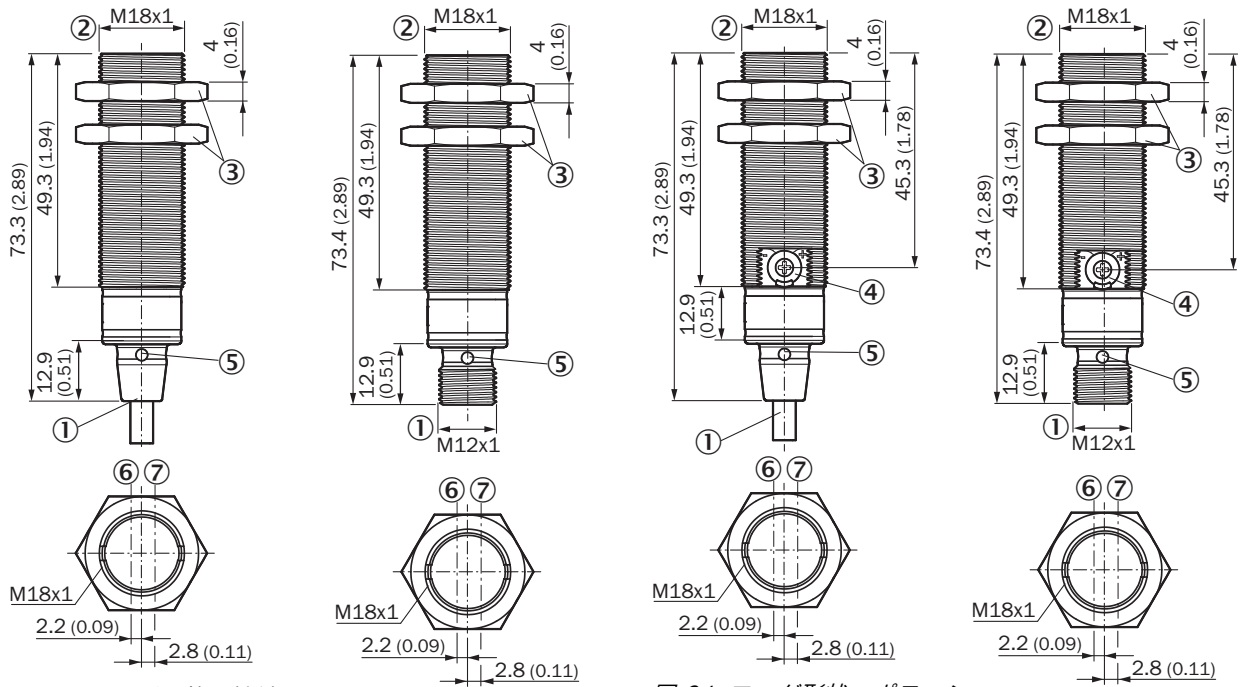
- ① 接続
- ② 取付ネジ M18 x 1
- ③ 固定ナット (2 x); WS24、ステンレススチール
- ④ ポテンシヨメータ、270°
- ⑤ LED 表示 (4 x)
- ⑥ 光軸、受光器
- ⑦ 光軸、投光器



図 86: 操作要素: 感度調節

74 取付

センサ (投光器と受光器) を適切な取付ブラケットに取付けます (SICK 付属品カタログを参照)。投光器と受光器を互いに方向調整します。

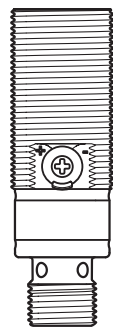
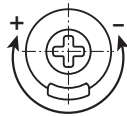
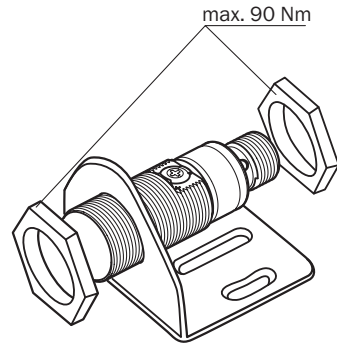

センサの締付トルクの最大許容値 90 Nm を遵守してください。



注意事項

透過形光電スイッチひとつおきに、投光器と受光器の配置を入れ替え、透過形光電スイッチ同士の間には十分な間隔を保ちます。



図 87: 複数の透過形光電スイッチの配置

75 電子装備

センサの接続は無電圧 ($U_V = 0\text{ V}$) で行わなければなりません。接続タイプに応じて以下の情報を遵守してください:

- コネクタ接続: ピン配置
- ケーブル: 芯線色

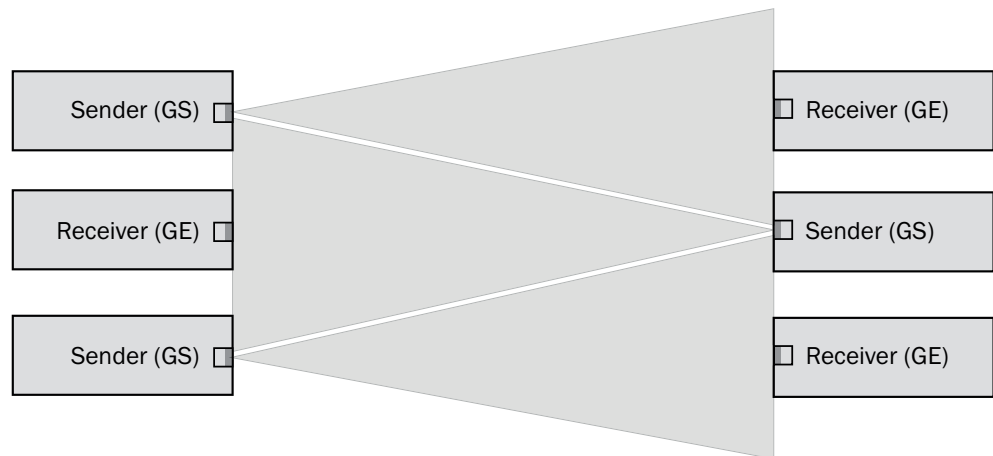
すべての電気機器を接続してから供給電圧 ($V_S > 0\text{ V}$) を印加、あるいは電源を入れてください。センサの緑色の LED 表示が点灯します。

配線図の説明 (表 2 および 3):

Q / \bar{Q} = スイッチング出力

TE / テスト = テスト入力 (参照 表 54)

n. c. = 未接続

DC: 10... 30 V DC、参照 „技術仕様“, ページ 97

表 51: DC, GRS



GRS18(S)V	D11xxx	D13x2/4x	D13x1/3x	D24xxx	D23xd/4x	D23x1/3x
1	+ (L+)	+ (L+)	+ (L+)	+ (L+)	+ (L+)	+ (L+)
2	n. c.	n. c.	n. c.	n. c.	n. c.	n. c.
3	- (M)	- (M)	- (M)	- (M)	- (M)	- (M)
4	Test	Test	n. c.	Q	Test	n. c.
	 <p>1 = 茶 2 = 白 3 = 青 4 = 黒 0.14 mm² AWG26</p>	 <p>1 = 茶 2 = 白 3 = 青 4 = 黒 0.14 mm² AWG26</p>				

表 52: DC, GRE

GRE18(S)V	x11xxx	x13xxx	x24xxx	x23xxx
1	+ (L+)	+ (L+)	+ (L+)	+ (L+)
2	\bar{Q}	n. c.	\bar{Q}	n. c.
3	- (M)	- (M)	- (M)	- (M)
4	Q	Q	Q	Q
	 <p>1 = 茶 2 = 白 3 = 青 4 = 黒 0.14 ... 1.5 mm² AWG26</p>	 <p>1 = 茶 - 3 = 青 4 = 黒 0.14 ... 1.5 mm² AWG26</p>		

表 53: DC

PNP: Q (≤ 100 mA)		
NPN: Q (≤ 100 mA)		
PNP: \bar{Q} (≤ 100 mA)		
NPN: \bar{Q} (≤ 100 mA)		

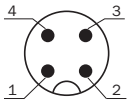
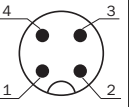
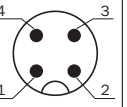
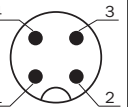
表 54: Test

	Test

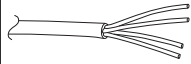
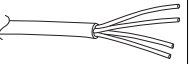
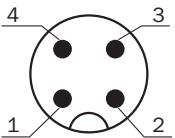
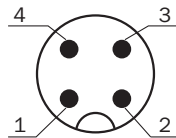
76 コミッショニング

1 光軸調整

投光器を受光器に合わせて光軸調整します。赤色の投光軸が受光器に照射されるように、位置決めします。ヒント: 白紙またはリフレクタを光軸調整の補助手段として使用してください。投光器から受光器への視界が遮られたり、照射経路に対象物があるではありません [参照 図]。センサの光開口部 (フロントカバー) が全く遮られないよう注意してください。

投光器を受光器に合わせて光軸調整します。赤外光 (不可視) が受光器に照射されるように位置決めします。光軸調整が正しいかどうかは、LED 表示灯によってのみ確認できます。これについては、図と表 53 を参照。投光器から受光器への視界が遮られたり、照射経路に対象物があるではありません。センサの光開口部 (フロントカバー) が全く遮られないよう注意してください。



図: 光軸調整

2 検出距離

使用条件を遵守してください; 投光器と受光器の間隔を対応する図 [参照 図 0] と照合します (x = 検出距離、 y = 予備能)。

複数の透過形光電スイッチを隣り合わせに取付けて使用する場合、透過形光電スイッチひとつおきに投光器と受光器の配置を入れ替え、透過形光電スイッチの間に十分な間隔を保つことをお勧めします。それにより相互干渉を回避することができます [参照 図 87]。

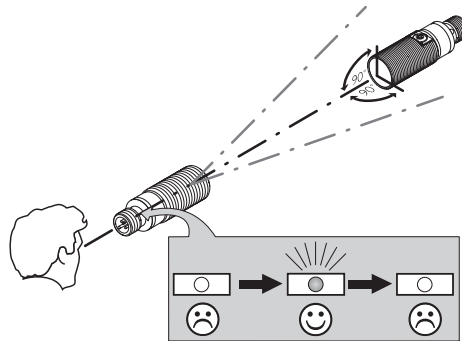
Operating reserve

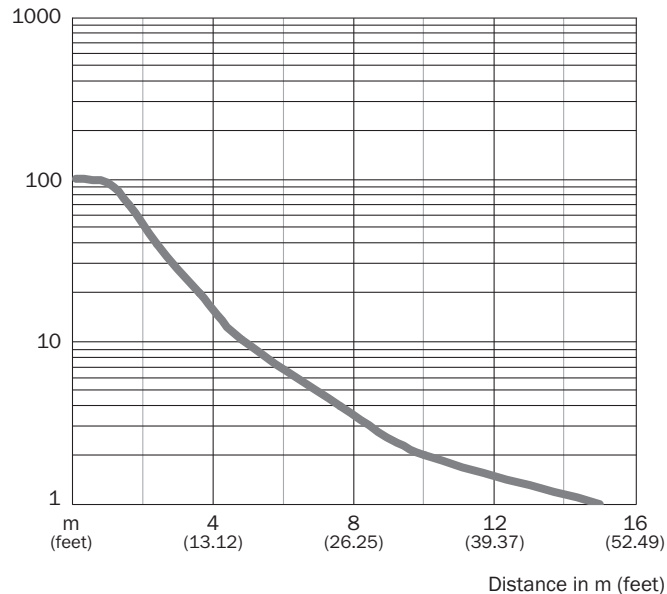

機能を点検するために、と表 3 を使用します。スイッチング出力が表 3 に従った動作を示さない場合は、使用条件を確認してください。故障診断の項目を参照。



表 55: 検出距離の定義

	GRSE18(S)V
①	0 ... 15 m

① 検出距離

3 感度設定

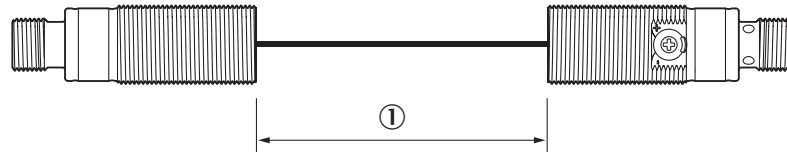
設定不要なセンサ: センサは設定され、動作準備が整っています。

ポテンシオメータ (タイプ: 270°) で感度を設定します。右へ回すと予備能が増大、左へ回すと予備能が減少します。ポテンシオメータを「最大」に設定することをお勧めします。

センサは設定され動作準備が整いました。

4 テスト入力

テスト入力: このセンサ GRSE18(S)V には、テスト入力 (配線図 [表 51] では「TE」または「Test」) が搭載されており、これによって投光器はオフになり、つまりセンサが正しく機能しているかどうかを点検することができます。LED 表示灯付きのメスケーブルコネクタを使用する場合は、TE が適切に配置されているかどうか注意してください。

投光器と受光器の間に対象物があってはなりません。テスト入力を起動します (配線図 [表 51] 参照、TE は 0 V へ)。投光 LED がオフになるか、または対象物の検出がシミュレーションされます。機能を点検するためには次の表を使用します。スイッチング出力が以下の表に従った動作を示さない場合は、使用条件を確認してください。故障診断の項目を参照。

77 トラブルシューティング

トラブルシューティングの表は、センサが機能しなくなった場合に、どのような対策を講じるべきかを示しています。

77.1 トラブルシューティング表

表 56: トラブルシューティング

LED 表示灯/故障パターン	原因	対策
緑色の LED が点灯しない	無電圧、または電圧が限界値以下	電源を確認し、すべての電気接続 (ケーブルおよびプラグ接続) を確認します
緑色の LED が点灯しない	電圧がきていない又は不安定	安定した電源電圧が供給されていることを確認します
緑色の LED が点灯しない	センサの異常	電源に問題がなければ、センサを交換します
緑色の LED が点灯、対象物が検出された際に出力信号がない	テスト入力 (Test) が正しく接続されていない	TI の接続に関する注意事項を参照してください
黄色い LED が点滅	センサの動作準備はまだ整っているが、動作条件が最適ではない	動作条件の点検: 光軸 (光軸スポット) を完全に受光器に合わせます。 / 光学面の洗浄 / 感度 (ポテンシオメータ) を新規設定 / ポテンシオメータを最大感度に設定した場合: 投光器と受光器の間

LED 表示灯/故障パターン	原因	対策
		隔を短くする/ 検出距離を点検し、必要に応じて調整する、参照表 55。
黄色い LED が点灯、光軸に対象物がない	透過形光電センサの投光光軸が、別の（隣接する）透過形光電センサの受光器にあたる	透過形光電スイッチひとつおきに、投光器と受光器の配置を入れ替え、透過形光電スイッチ同士の間には十分な間隔を保ちます:参照図 87。

78 解体および廃棄

センサは必ず該当国の規制にしたがって処分してください。廃棄処理の際には、できるだけ構成材料をリサイクルするよう努めてください（特に貴金属類）。

79 メンテナンス

SICK センサはメンテナンスフリーです。

定期的に以下を行うことをお勧めしています：

- ・ レンズ境界面の清掃
- ・ ネジ締結と差込み締結の点検

機器を改造することは禁止されています。

記載内容につきましては予告なしに変更する場合がございますのであらかじめご了承ください。指定された製品特性および技術データは保証書ではありません。

80 技術仕様

	GRSE18(S)-xxx2xV, Infraredlight	GRSE18(S)-xxx4xV, visible red light
検出範囲	0 ... 10 m	0 ... 10 m
最大検出範囲	0 ... 15 m	0 ... 15 m
光点のスポット径/距離	420 mm / 10 m	250 mm / 10 m
供給電圧 U_V	DC 10 ... 30 V ²	DC 10 ... 30 V ²
出力電流 I_{max}	100 mA	100 mA
最大スイッチング周波数	1,000 / s ⁵	1,000 / s ⁵
最大応答時間	< 0,5 ms ⁶	< 0,5 ms ⁶
保護等級	IP67,IP68,IP69K ¹¹	IP67,IP68,IP69K ¹¹
保護クラス	III ⁸	III ⁸
回路保護	A,B,D ¹⁰	A,B,D ¹⁰
周辺温度 (作動中)	-25 °C ... +55 °C	-25 °C ... +55 °C

¹ Tastgut mit 90 % Remission (bezogen auf Standard-Weiß DIN 5033)

² Grenzwerte; Betrieb im kurzschlussgeschützten Netz max. 8 A; Restwelligkeit max. 5 V_{ss}

⁴ Gebrauchskategorie: AC-15, DC-13 (EN 60947-1)

⁵ Mit Hell- / Dunkelverhältnis 1:1

⁶ Signallaufzeit bei ohmscher Last

⁷ gültig für Q\ auf Pin2, wenn per Software konfiguriert

⁸ Bemessungsspannung DC 50 V

¹⁰ A = U_V-Anschlüsse verpolsicher

B = Ein- und Ausgänge verpolsicher

D = Ausgänge überstrom- und kurzschlussfest

¹¹ IP68: EN 60529 に準拠 (水深 10 m / 24 h)。

IP69K: Nach ISO 20653:2013-03.

GRSE18(S)V

Цилиндрические фотоэлектрические датчики



de
en
es
fr
it
ja
pt
ru
zh

Описание продукта

GR18 Inox
GRSE18(S)V

Изготовитель

SICK AG
Erwin-Sick-Str. 1
79183 Waldkirch
Deutschland (Германия)

Место изготовления

SICK, Малайзия

Правовые примечания

Данная документация защищена авторским правом. Обоснованные таким образом права сохраняются за фирмой SICK AG. Тиражирование документации или ее части допускается только в рамках положений закона об авторских правах. Внесение в документацию изменений, сокращение или перевод ее содержимого без однозначного письменного согласия фирмы SICK AG запрещено.

Товарные знаки, упомянутые в данном документе, являются собственностью соответствующего владельца.

© SICK AG Все права защищены.

Оригинальный документ

Настоящий документ является оригинальным документом SICK AG.



Содержание

81	Указания по технике безопасности.....	101
82	Применение по назначению.....	101
83	Элементы управления и индикаторы.....	101
84	Монтаж.....	102
85	Подключение электроники.....	103
86	Ввод в эксплуатацию.....	106
87	Устранение неисправностей.....	107
	87.1 Таблица устранения неисправностей.....	107
88	Демонтаж и утилизация.....	108
89	Техобслуживание.....	108
90	Технические характеристики.....	109

81 Указания по технике безопасности

- Перед вводом в эксплуатацию изучите руководство по эксплуатации.
-  Подключение, монтаж и установку поручать только специалистам.
- Данное устройство не является оборудованием для обеспечения безопасности в соответствии с Директивой ЕС по машинному оборудованию.
- Power supply: Class 2
Enclosure type 1
- При вводе в эксплуатацию следует защитить устройство от попадания влаги и грязи.
- В данном руководстве по эксплуатации содержится информация, необходимая на протяжении всего жизненного цикла датчика.

82 Применение по назначению

GRSE18(S)V является однолучевым фотозлектрическим датчиком (в дальнейшем называемым «датчик») и используется для оптической бесконтактной регистрации предметов, животных и людей. Для эксплуатации необходимы передатчик (WS) и приёмник (WE). В случае использования устройства для иных целей, а также в случае внесения в изделие изменений, любые претензии к компании SICK AG на предоставление гарантии исключаются.

83 Элементы управления и индикаторы

Таблица 57: Габаритные чертежи



Рисунок 88: Короткий вариант, соединительный кабель



Рисунок 89: Короткий вариант, разъем M12

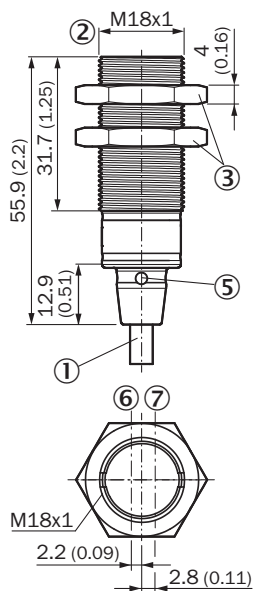

Рисунок 90: Короткий вариант, потенциометр, соединительный кабель

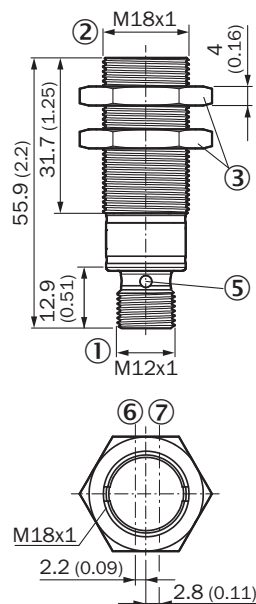

Рисунок 91: Короткий вариант, потенциометр, разъем M12

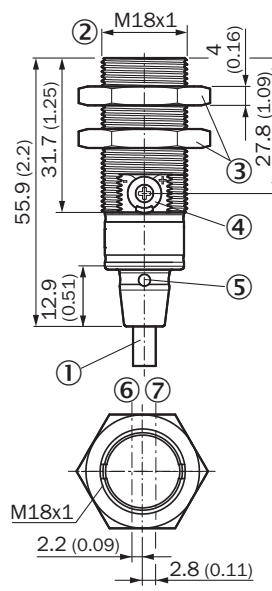

Рисунок 92: Длинный вариант, соединительный кабель

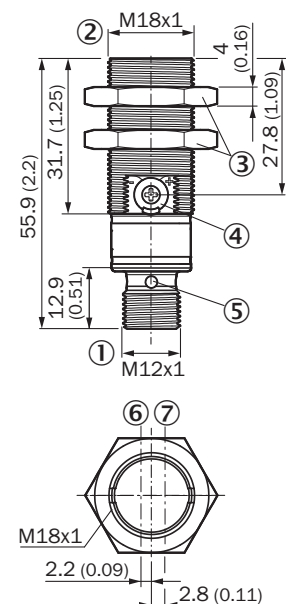

Рисунок 93: Длинный вариант, разъем M12

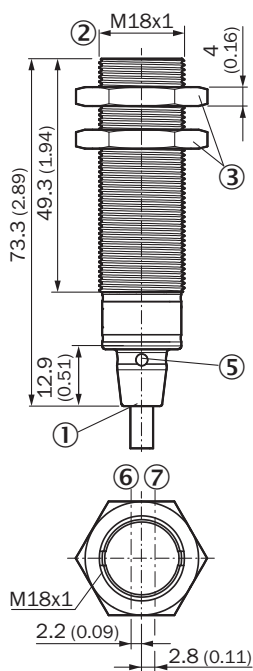

Рисунок 94: Длинный вариант, потенциометр, соединительный кабель

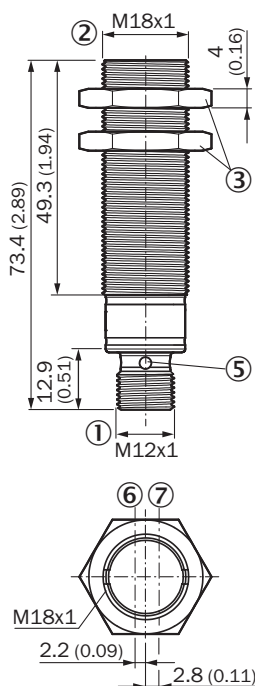

Рисунок 95: Длинный вариант, потенциометр, разъем M12

- ① Соединение
- ② Крепежная резьба M18 x 1
- ③ Крепежная гайка (2 х); WS24, нержавеющая сталь
- ④ Потенциометр, 270°
- ⑤ Светодиодный индикатор (4 штуки)
- ⑥ Оптическая ось, приемник
- ⑦ Оптическая ось, передатчик

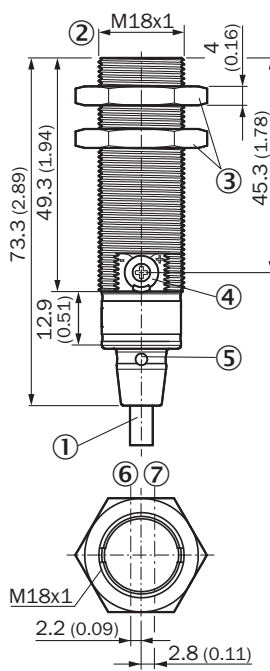

Рисунок 96: Элемент управления: регулировка чувствительности

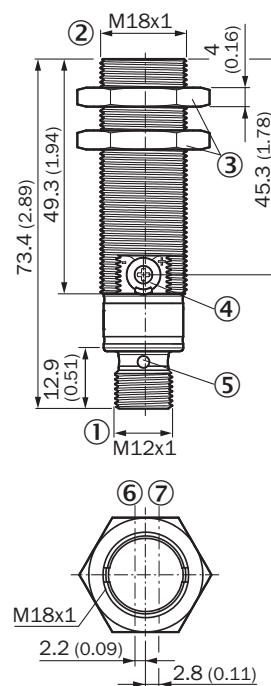
84 Монтаж

Установите датчики (передатчик и приёмник) на подходящем крепёжном уголке (см. программу принадлежностей от SICK). Выровняйте передатчик и приёмник друг относительно друга.

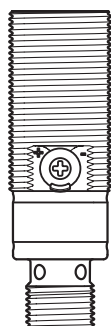
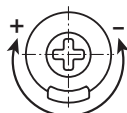
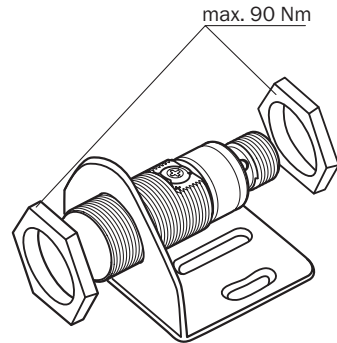

Выдерживайте максимально допустимый момент затяжки датчика в 90 Нм.



УКАЗАНИЕ

На каждом втором однолучевом фоторелейном барьере поменять местами передатчик и приемник каждого второго однолучевого фоторелейного барьера или же выдерживать достаточное расстояние между однолучевыми фоторелейными барьерами.



Рисунок 97: Расположение нескольких однолучевых фотоэлектрических датчиков

85 Подключение электроники

Подключение датчиков должно производиться при отключенном напряжении питания ($U_V = 0\text{ В}$). В зависимости от типа подключения следует принять во внимание следующую информацию:

- Штепсельный разъём: расположение выводов
- Кабель: цвет жилы

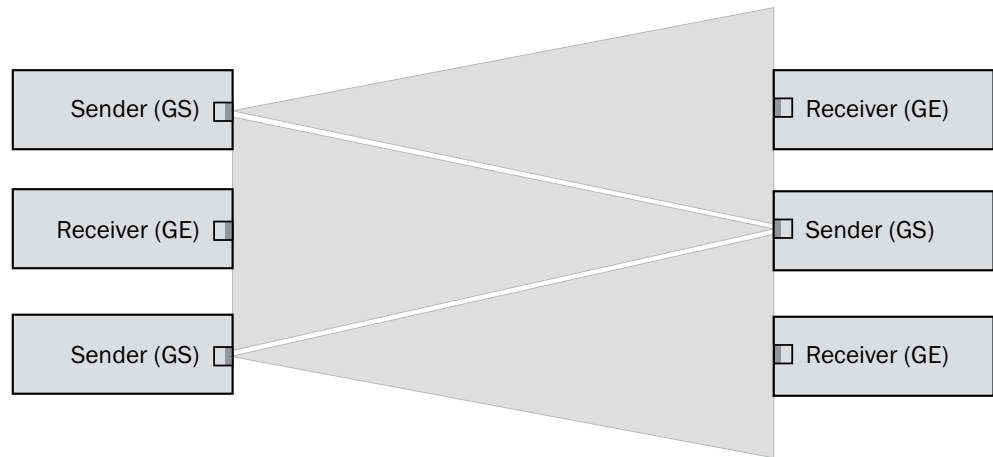
Подавать напряжение питания и включать источник напряжения только после завершения подключения всех электрических соединений ($U_V > 0\text{ В}$). На датчике загорается зелёный светодиодный индикатор.

Пояснения к схеме подключений (таблицы 2 и 3):

Q / \bar{Q} = переключающие выходы

TE/тест = тестовый вход (см. таблица 61)

n. c. = не подключен

DC: 10 ... 30 В пост. тока см. „Технические характеристики“, страница 109

Таблица 58: DC, GRS



GRS18(S)V	D11xxx	D13x2/4x	D13x1/3x	D24xxx	D23xd/4x	D23x1/3x
1	+ (L+)	+ (L+)	+ (L+)	+ (L+)	+ (L+)	+ (L+)
2	н. с.	н. с.	н. с.	н. с.	н. с.	н. с.
3	- (M)	- (M)	- (M)	- (M)	- (M)	- (M)
4	Тест	Тест	н. с.	Q	Тест	н. с.
	 1 = brn (коричневый) 2 = wht (белый) 3 = blu (синий) 4 = blk (черный) 0,14 мм ² AWG26	 1 = brn (коричневый) 2 = wht (белый) 3 = blu (синий) 4 = blk (черный) 0,14 мм ² AWG26				

Таблица 59: DC, GRE

GRE18(S)V	x11xxx	x13xxx	x24xxx	x23xxx
1	+ (L+)	+ (L+)	+ (L+)	+ (L+)
2	\bar{Q}	н. с.	\bar{Q}	н. с.
3	- (M)	- (M)	- (M)	- (M)
4	Q	Q	Q	Q
	 1 = brn (коричневый) 2 = wht (белый) 3 = blu (синий) 4 = blk (черный) 0,14 ... 1,5 мм ² AWG26	 1 = brn (коричневый) - 3 = blu (синий) 4 = blk (черный) 0,14 ... 1,5 мм ² AWG26		

Таблица 60: пост. ток

PNP: Q (≤ 100 mA)		
NPN: Q (≤ 100 mA)		
PNP: \bar{Q} (≤ 100 mA)		
NPN: \bar{Q} (≤ 100 mA)		

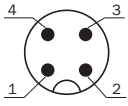
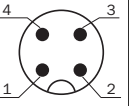
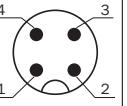
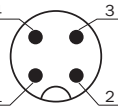
Таблица 61: Тест

	Тест

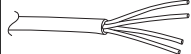
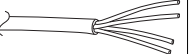
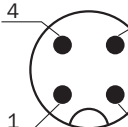
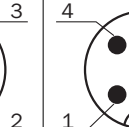
86 Ввод в эксплуатацию

1 Выравнивание

Произведите выверку передатчика по одной оси с приемником. Выберите такую позицию, чтобы красный луч передатчика попадал на приёмник. Совет: в качестве приспособления для выверки используйте лист белой бумаги или отражатель. Передатчик должен иметь свободную траекторию до приёмника, нахождение объектов на пути луча не допускается [см. рисунок]. Необходимо следить за тем, чтобы оптические отверстия (передние стекла) датчиков были совершенно свободными.

Произведите выверку передатчика по одной оси с приемником. Выберите такую позицию, чтобы инфракрасный луч (он не виден) попадал на приемник. Правильность выверки можно определить с помощью светодиодных индикаторов. См. рисунок и таблица 60. Передатчик должен иметь свободную траекторию до приёмника, нахождение объектов на пути луча не допускается. Необходимо следить за тем, чтобы оптические отверстия (передние стекла) датчиков были совершенно свободными.



Рисунок: Выравнивание

2 Расстояние срабатывания

Учёт условий применения: скорректировать дистанцию между передатчиком и приёмником с помощью соответствующей диаграммы [см. рисунок 0] (x = дистанция переключения, y = функциональный резерв).

При применении нескольких однолучевых фоторелейных барьеров, которые устанавливаются рядом друг с другом, рекомендуется поменять местами передатчик и приемник каждого второго однолучевого фоторелейного барьера или же выдержать достаточное расстояние между однолучевыми фоторелейными барьерами. Таким образом можно избежать взаимного воздействия [см. рисунок 97].

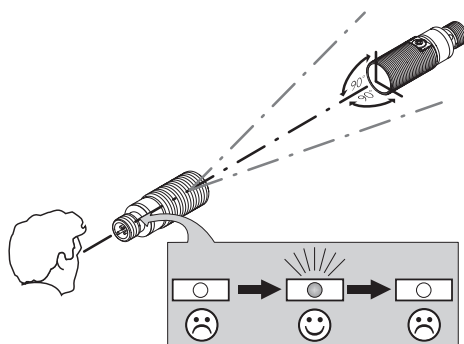
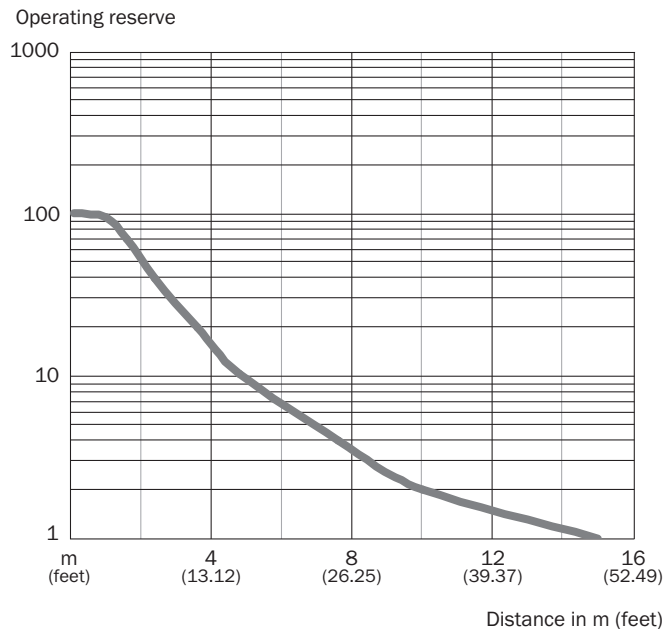

Для проверки функционирования воспользуйтесь и таблицей 3. Если характер поведения переключающего выхода не соответствует Таблице 3, проверить условий эксплуатации. См. раздел «Диагностика неисправностей».



Рисунок 98: расстояния срабатывания

Таблица 62: Определение расстояния срабатывания

	GRSE18(S)V
①	0 ... 15 м

① Расстояние срабатывания

3 Настройка чувствительности

Датчик без возможности настройки: датчик настроен и готов к эксплуатации. Чувствительность датчика регулируется с помощью потенциометра (тип: 270 °). Вращение вправо: увеличение функционального резерва, вращение влево: уменьшение функционального резерва. Рекомендуется устанавливать потенциометр на максимум («Maximal»).

Датчик настроен и готов к эксплуатации.

4 Тестовый вход

Тестовый вход: датчики GRSE18(S)V имеют тестовый вход («TE» или «Test» на схеме электрических соединений [таблица 58]), с помощью которого можно выключить датчик и тем самым проверить исправность его функционирования: при использовании розеток со светодиодными индикаторами следите за правильным подключением TE.

Между передатчиком и приемником не должно быть никакого объекта, активируйте тестовый вход (см. схему электрических соединений [таблица 58], TE по 0 В). Светодиод передатчика отключается или моделируется распознавание объекта. Для проверки функционирования воспользуйтесь следующей таблицей. Если характер поведения переключающего выхода не соответствует следующей Таблице, проверить условий эксплуатации. См. раздел «Диагностика неисправностей».

87 Устранение неисправностей

В таблице Устранение неисправностей показано, какие меры необходимо предпринять, если датчики не работают.

87.1 Таблица устранения неисправностей

Таблица 63: Устранение неисправностей

Светодиодный индикатор / картина неисправности	Причина	Меры по устранению
зеленый светодиод не горит	нет напряжения питания или оно ниже нижнего предельного значения	Проверить напряжения питания, всю схему электроподключения (проводку и разъемные соединения)
зеленый светодиод не горит	Пропадание напряжения питания	Обеспечить надежную подачу напряжения питания без его пропадания
зеленый светодиод не горит	Сенсор неисправен	Если напряжение питания в порядке, то заменить сенсор

Светодиодный индикатор / картина неисправности	Причина	Меры по устранению
зеленый светодиод горит, выходной сигнал детектирования объекта отсутствует	Тестовый вход (Test) неверно подключен	См. указания по подключению ТЕ
желтый светодиод мигает	Сенсор пока еще готов к работе, но эксплуатационные условия не оптимальны	Проверить эксплуатационные условия: Полностью сориентировать световой луч (световое пятно) на приемник / чистка оптических поверхностей / заново настроить чувствительность (потенциометром) / если потенциометр уже настроен на макс. чувствительность: уменьшить расстояние между передатчиком и приёмником/ проверить и, при необходимости, скорректировать расстояние срабатывания, см. таблица 62 .
желтый светодиод горит, объект на пути луча отсутствует	Световой луч однолучевого фоторелейного барьера попадает на приемник другого (соседнего) однолучевого фоторелейного барьера	На каждом втором однолучевом фотозлектрическом датчике поменять расположение передатчика и приёмника или соблюдать достаточное расстояние между однолучевыми фотозлектрическими датчиками, см. рисунок 97 .

88 Демонтаж и утилизация

Утилизацию сенсоров следует проводить согласно национальным предписаниям по утилизации. Следует стремиться к повторному использованию содержащихся в них материалов (прежде всего, драгоценных металлов).

89 Техобслуживание

Датчики SICK не нуждаются в техобслуживании.

Рекомендуется регулярно

- очищать оптические ограничивающие поверхности
- проверять прочность резьбовых и штекерных соединений

Запрещается вносить изменения в устройства.

Право на ошибки и внесение изменений сохранено. Указанные свойства изделия и технические характеристики не являются гарантией.

90 Технические характеристики

	GRSE18(S)-xxx2xV, Infraredlight	GRSE18(S)-xxx4xV, visible red light
Расстояние срабатывания	0 ... 10 m	0 ... 10 m
Расстояние срабатывания, макс.	0 ... 15 m	0 ... 15 m
Диаметр светового пятна/расстояние	420 mm / 10 m	250 mm / 10 m
Напряжение питания U_V	DC 10 ... 30 V ²	DC 10 ... 30 V ²
Выходной ток $I_{\text{макс.}}$	100 mA	100 mA
Частота срабатывания макс.	1,000 / s ⁵	1,000 / s ⁵
Время отклика макс.	< 0,5 ms ⁶	< 0,5 ms ⁶
Класс защиты	IP67,IP68,IP69K ¹¹	IP67,IP68,IP69K ¹¹
Класс защиты	III ⁸	III ⁸
Схемы защиты	A,B,D ¹⁰	A,B,D ¹⁰
Диапазон рабочих температур	-25 °C ... +55 °C	-25 °C ... +55 °C

- 1 Tastgut mit 90 % Remission (bezogen auf Standard-Weiß DIN 5033)
 2 Grenzwerte; Betrieb im kurzschlussgeschützten Netz max. 8 A; Restwelligkeit max. 5 V_{ss}
 4 Gebrauchskategorie: AC-15, DC-13 (EN 60947-1)
 5 Mit Hell- / Dunkelverhältnis 1:1
 6 Signallaufzeit bei ohmscher Last
 7 gültig für Q\ auf Pin2, wenn per Software konfiguriert
 8 Bemessungsspannung DC 50 V
 10 A = U_V-Anschlüsse verpolsicher
 B = Ein- und Ausgänge verpolsicher
 D = Ausgänge überstrom- und kurzschlussfest
 11 IP68: согласно EN 60529 (глубина воды 10 м / 24 ч).
 IP69K: согласно ISO 20653:2013-03.

Australia

Phone +61 3 9457 0600
1800 334 802 - tollfree
E-Mail sales@sick.com.au

Austria

Phone +43 22 36 62 28 8-0
E-Mail office@sick.at

Belgium/Luxembourg

Phone +32 2 466 55 66
E-Mail info@sick.be

Brazil

Phone +55 11 3215-4900
E-Mail marketing@sick.com.br

Canada

Phone +1 905 771 14 44
E-Mail information@sick.com

Czech Republic

Phone +420 2 57 91 18 50
E-Mail sick@sick.cz

Chile

Phone +56 2 2274 7430
E-Mail info@schadler.com

China

Phone +86 20 2882 3600
E-Mail info.china@sick.net.cn

Denmark

Phone +45 45 82 64 00
E-Mail sick@sick.dk

Finland

Phone +358-9-2515 800
E-Mail sick@sick.fi

France

Phone +33 1 64 62 35 00
E-Mail info@sick.fr

Germany

Phone +49 211 5301-301
E-Mail info@sick.de

Hong Kong

Phone +852 2153 6300
E-Mail ghk@sick.com.hk

Hungary

Phone +36 1 371 2680
E-Mail office@sick.hu

India

Phone +91 22 6119 8900
E-Mail info@sick-india.com

Israel

Phone +972 4 6881000
E-Mail info@sick-sensors.com

Italy

Phone +39 02 274341
E-Mail info@sick.it

Japan

Phone +81 3 5309 2112
E-Mail support@sick.jp

Malaysia

Phone +6 03 8080 7425
E-Mail enquiry.my@sick.com

Mexico

Phone +52 (472) 748 9451
E-Mail mario.garcia@sick.com

Netherlands

Phone +31 30 2044 000
E-Mail info@sick.nl

New Zealand

Phone +64 9 415 0459
0800 222 278 - tollfree
E-Mail sales@sick.co.nz

Norway

Phone +47 67 81 50 00
E-Mail sick@sick.no

Poland

Phone +48 22 539 41 00
E-Mail info@sick.pl

Romania

Phone +40 356 171 120
E-Mail office@sick.ro

Russia

Phone +7 495 775 05 30
E-Mail info@sick.ru

Singapore

Phone +65 6744 3732
E-Mail sales.gsg@sick.com

Slovakia

Phone +421 482 901201
E-Mail mail@sick-sk.sk

Slovenia

Phone +386 591 788 49
E-Mail office@sick.si

South Africa

Phone +27 11 472 3733
E-Mail info@sickautomation.co.za

South Korea

Phone +82 2 786 6321
E-Mail info@sickkorea.net

Spain

Phone +34 93 480 31 00
E-Mail info@sick.es

Sweden

Phone +46 10 110 10 00
E-Mail info@sick.se

Switzerland

Phone +41 41 619 29 39
E-Mail contact@sick.ch

Taiwan

Phone +886 2 2375-6288
E-Mail sales@sick.com.tw

Thailand

Phone +66 2645 0009
E-Mail Ronnie.Lim@sick.com

Turkey

Phone +90 216 528 50 00
E-Mail info@sick.com.tr

United Arab Emirates

Phone +971 4 88 65 878
E-Mail info@sick.ae

United Kingdom

Phone +44 1727 831121
E-Mail info@sick.co.uk

USA

Phone +1 800 325 7425
E-Mail info@sick.com

Vietnam

Phone +84 945452999
E-Mail Ngo.Duy.Linh@sick.com

Further locations at www.sick.com

