

**LBV 330**  
- transistor (NPN/PNP)



GB

## Contents

<b>1</b>	<b>About this document</b>	
1.1	Function . . . . .	4
1.2	Target group . . . . .	4
1.3	Symbolism used . . . . .	4
<b>2</b>	<b>For your safety</b>	
2.1	Authorised personnel . . . . .	5
2.2	Appropriate use . . . . .	5
2.3	Warning about misuse . . . . .	5
2.4	General safety instructions . . . . .	5
2.5	Safety label on the instrument . . . . .	6
2.6	CE conformity . . . . .	6
2.7	Safety instructions for Ex areas . . . . .	6
<b>3</b>	<b>Product description</b>	
3.1	Structure . . . . .	7
3.2	Principle of operation . . . . .	8
3.3	Operation . . . . .	8
3.4	Storage and transport . . . . .	9
<b>4</b>	<b>Mounting</b>	
4.1	General instructions . . . . .	10
4.2	Mounting instructions . . . . .	11
<b>5</b>	<b>Connecting to power supply</b>	
5.1	Preparing the connection . . . . .	16
5.2	Connection procedure . . . . .	16
5.3	Wiring plan, single chamber housing . . . . .	17
<b>6</b>	<b>Set up</b>	
6.1	In general . . . . .	20
6.2	Adjustment elements . . . . .	20
6.3	Functional chart . . . . .	21
<b>7</b>	<b>Maintenance and fault rectification</b>	
7.1	Maintenance . . . . .	23
7.2	Rectify faults . . . . .	23
7.3	Exchanging the electronics module . . . . .	24
7.4	Instrument repair . . . . .	26
<b>8</b>	<b>Dismounting</b>	
8.1	Dismounting steps . . . . .	27
8.2	Disposal . . . . .	27
<b>9</b>	<b>Supplement</b>	
9.1	Technical data . . . . .	28
9.2	Dimensions . . . . .	31

### Supplementary documentation



#### Information:

Supplementary documents appropriate to the ordered version come with the delivery. You can find them listed in chapter "*Product description*".

### Instructions manuals for accessories and replacement parts



#### Tip:

To ensure reliable setup and operation of your LBV 330, we offer accessories and replacement parts. The corresponding documentations are:

- 36052 - Electronics module LBV series 300
- 36056 - Lock fitting for LBV 330, unpressurized operation
- 36057 - Lock fitting for LBV 330, pressure range -1 ... 16 bar

# 1 About this document

## 1.1 Function

This operating instructions manual provides all the information you need for mounting, connection and setup as well as important instructions for maintenance and fault rectification. Please read this information before putting the instrument into operation and keep this manual accessible in the immediate vicinity of the device.

## 1.2 Target group

This operating instructions manual is directed to trained qualified personnel. The contents of this manual should be made available to these personnel and put into practice by them.

## 1.3 Symbolism used



### Information, tip, note

This symbol indicates helpful additional information.



**Caution:** If this warning is ignored, faults or malfunctions can result.

**Warning:** If this warning is ignored, injury to persons and/or serious damage to the instrument can result.

**Danger:** If this warning is ignored, serious injury to persons and/or destruction of the instrument can result.



### Ex applications

This symbol indicates special instructions for Ex applications.



### List

The dot set in front indicates a list with no implied sequence.



### Action

This arrow indicates a single action.



### Sequence

Numbers set in front indicate successive steps in a procedure.

## 2 For your safety

### 2.1 Authorised personnel

All operations described in this operating instructions manual must be carried out only by trained specialist personnel authorised by the plant operator.

During work on and with the device the required personal protective equipment must always be worn.

### 2.2 Appropriate use

The LBV 330 is a sensor for level detection.

You can find detailed information on the application range in chapter "*Product description*".

Operational reliability is ensured only if the instrument is properly used according to the specifications in the operating instructions manual as well as possible supplementary instructions.

For safety and warranty reasons, any invasive work on the device beyond that described in the operating instructions manual may be carried out only by personnel authorised by the manufacturer. Arbitrary conversions or modifications are explicitly forbidden.

### 2.3 Warning about misuse

Inappropriate or incorrect use of the instrument can give rise to application-specific hazards, e.g. vessel overfill or damage to system components through incorrect mounting or adjustment.

### 2.4 General safety instructions

This is a high-tech instrument requiring the strict observance of standard regulations and guidelines. The user must take note of the safety instructions in this operating instructions manual, the country-specific installation standards as well as all prevailing safety regulations and accident prevention rules.

The instrument must only be operated in a technically flawless and reliable condition. The operator is responsible for trouble-free operation of the instrument.

During the entire duration of use, the user is obliged to determine the compliance of the necessary occupational safety measures with the current valid rules and regulations and also take note of new regulations.

## **2.5 Safety label on the instrument**

The safety approval markings and safety tips on the device must be observed.

## **2.6 CE conformity**

This device fulfills the legal requirements of the applicable EC guidelines. By attaching the CE mark, we provide confirmation of successful testing.

## **2.7 Safety instructions for Ex areas**

Please note the Ex-specific safety information for installation and operation in Ex areas. These safety instructions are part of the operating instructions manual and come with the Ex-approved instruments.

## 3 Product description

### 3.1 Structure

#### Scope of delivery

The scope of delivery encompasses:

- Point level sensor LBV 330
- Documentation
  - this operating instructions manual
  - Ex-specific "*Safety instructions*" (with Ex versions)
  - if necessary, further certificates

#### Constituent parts

The LBV 330 consists of the following components:

- Housing cover
- Housing with electronics
- Process fitting with tuning fork

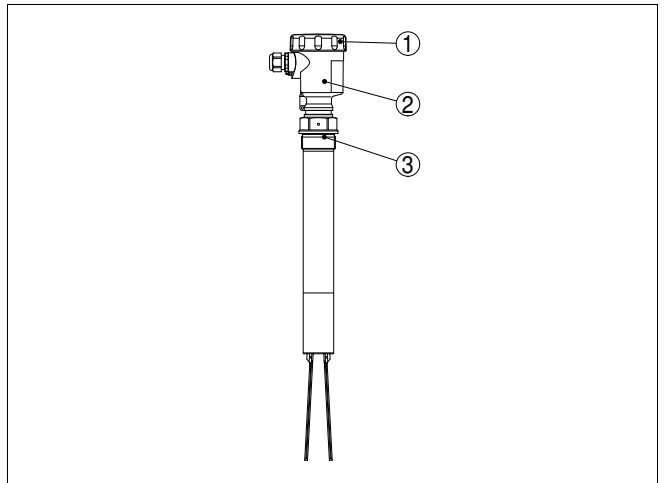

Fig. 1: LBV 330 - with plastic housing

- 1 Housing cover
- 2 Housing with electronics
- 3 Process fitting

#### Type label

The type label contains the most important data for identification and use of the instrument:

- Article number
- Serial number
- Technical data
- Article numbers, documentation

In addition to the type label outside on the instrument, you find the serial number also inside the instrument.

## 3.2 Principle of operation

### Application area

LBV 330 is a point level sensor with tuning fork for level detection.

It is designed for industrial use in all areas of process technology and is preferably used for bulk solids.

Typical applications are overfill and dry run protection. Thanks to its simple and robust measuring system, LBV 330 is virtually unaffected by the chemical and physical properties of the bulk solid.

It also works when subjected to strong external vibrations or changing products.

### Fault monitoring

The electronics module of LBV 330 monitors continuously the following criteria:

- Correct vibrating frequency
- Line break to the piezo drive

If one of the stated malfunctions is detected or in case of power failure, the electronics takes on a defined switching condition, i.e. the output is open (safe condition).

### Functional principle

The tuning fork is piezoelectrically energised and vibrates at its mechanical resonance frequency of approx. 150 Hz. When the tuning fork is submerged in the product, the vibration amplitude changes. This change is detected by the integrated electronics module and converted into a switching command.

### Voltage supply

LBV 330 is a compact instrument, i.e. it can be operated without external evaluation system. The integrated electronics evaluates the level signal and outputs a switching signal. With this switching signal, a connected device can be operated directly (e.g. a warning system, a PLC, a pump etc.).

The data for power supply are specified in chapter "*Technical data*".

## 3.3 Operation

With the factory setting, products with a density of  $> 0.02 \text{ g/cm}^3$  ( $0.0008 \text{ lbs/in}^3$ ) can be measured. The instrument can also be adapted to products with lower density  $> 0.008 \text{ g/cm}^3$  ( $0.0003 \text{ lbs/in}^3$ ).

On the electronics module you will find the following indicating and adjustment elements:

- Signal lamp for indication of the switching condition (green/red)
- Potentiometer for adaptation to the product density
- Mode switch for selecting the switching condition (min./max.)



### 3.4 Storage and transport

<b>Packaging</b>	<p>Your instrument was protected by packaging during transport. Its capacity to handle normal loads during transport is assured by a test according to DIN EN 24180.</p> <p>The packaging of standard instruments consists of environment-friendly, recyclable cardboard. In addition, the sensor is provided with a protective cover of paperboard. For special versions PE foam or PE foil is also used. Dispose of the packaging material via specialised recycling companies.</p>
<b>Transport</b>	<p>Transport must be carried out under consideration of the notes on the transport packaging. Nonobservance of these instructions can cause damage to the device.</p>
<b>Transport inspection</b>	<p>The delivery must be checked for completeness and possible transit damage immediately at receipt. Ascertained transit damage or concealed defects must be appropriately dealt with.</p>
<b>Storage</b>	<p>Up to the time of installation, the packages must be left closed and stored according to the orientation and storage markings on the outside.</p> <p>Unless otherwise indicated, the packages must be stored only under the following conditions:</p> <ul style="list-style-type: none"><li>● Not in the open</li><li>● Dry and dust free</li><li>● Not exposed to corrosive media</li><li>● Protected against solar radiation</li><li>● Avoiding mechanical shock and vibration</li></ul>
<b>Storage and transport temperature</b>	<ul style="list-style-type: none"><li>● Storage and transport temperature see chapter "<i>Supplement - Technical data - Ambient conditions</i>"</li><li>● Relative humidity 20 ... 85 %</li></ul>

## 4 Mounting

### 4.1 General instructions

#### Suitability for the process conditions

Make sure that all parts of the instrument exposed to the process, in particular the sensor element, process seal and process fitting, are suitable for the existing process conditions. These include above all the process pressure, process temperature as well as the chemical properties of the medium.

You can find the specifications in chapter "*Technical data*" or on the type label.

#### Switching point

In general, LBV 330 can be installed in any position. The instrument only has to be mounted in such a way that the vibrating element is at the height of the desired switching point.

#### Moisture

Use the recommended cables (see chapter "*Connecting to power supply*") and tighten the cable gland.

You can give your instrument additional protection against moisture penetration by leading the connection cable downward in front of the cable entry. Rain and condensation water can thus drain off. This applies mainly to outdoor mounting as well as installation in areas where high humidity is expected (e.g. through cleaning processes) or on cooled or heated vessels.

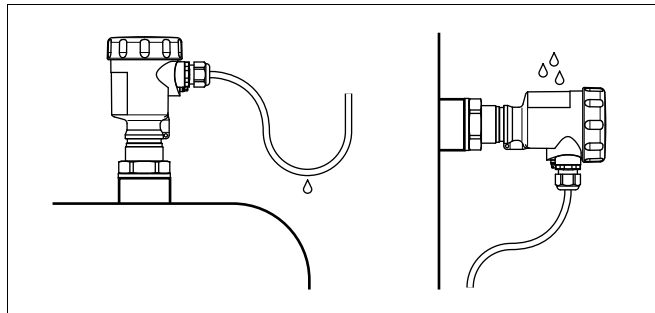

Fig. 2: Measures against moisture penetration

#### Transport

Do not hold LBV 330 on the vibrating element. Especially with flange and tube versions, the sensor can be damaged by the weight of the instrument.

Remove the protective cover just before mounting.

**Pressure/Vacuum**

The process fitting must be sealed if there is gauge or low pressure in the vessel. Before use, check if the seal material is resistant against the measured product and the process temperature.

The max. permissible pressure is specified in chapter "*Technical data*" or on the type label of the sensor.

**Handling**

The vibrating level switch is a measuring instrument and must be treated accordingly. Bending the vibrating element will destroy the instrument.



**Warning:**

The housing must not be used to screw the instrument in! Applying tightening force can damage internal parts of the housing.

Use the hexagon above the thread for screwing in.

## 4.2 Mounting instructions

**Agitators and fluidization**

Due to the effects of agitators, equipment vibration or similar, the level switch can be subjected to strong lateral forces. For this reason, do not use an overly long extension tube for LBV 330, but check if you can mount a short level switch on the side of the vessel in horizontal position.

Extreme vibration caused by the process or the equipment, e.g. agitators or turbulence in the vessel e.g. from fluidization, can cause the extension tube of LBV 330 to vibrate in resonance. This leads to increased stress on the upper weld joint. Should a longer tube version be necessary, you can provide a suitable support directly above the tuning fork to secure the extension tube.



This measure applies mainly to applications in Ex areas. Make sure that the tube is not subject to bending stress due to this measure.

**Inflowing medium**

If LBV 330 is mounted in the filling stream, unwanted false measurement signals can be generated. For this reason, mount LBV 330 at a position in the vessel where no disturbances, e.g. from filling openings, agitators, etc., can occur.

This applies particularly to instrument types with long extension tube.

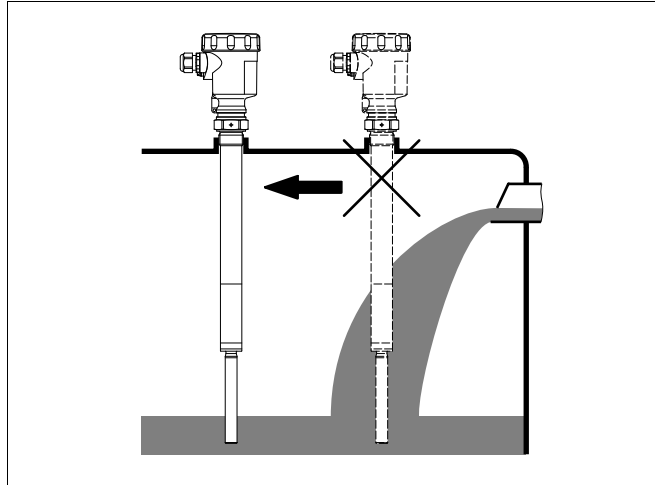

Fig. 3: Inflowing medium

#### Lock fitting

LBV 330 can be mounted with a lock fitting for height adjustment. Take note of the pressure information of the lock fitting.

#### Socket

The vibrating element should protrude into the vessel to avoid buildup. For that reason, avoid using mounting bosses for flanges and screwed fittings. This applies particularly to use with adhesive products.

#### Material cone

In silos for bulk solids, material cones can form and change the switching point. Please keep this in mind when installing the sensor in the vessel. We recommend selecting an installation location where the vibrating fork detects an average value of the material cone.

The tuning fork must be mounted in a way that takes the arrangement of the filling and emptying apertures into account.

To compensate measurement errors caused by the material cone in cylindrical vessels, the sensor must be mounted at a distance of  $d/6$  from the vessel wall.

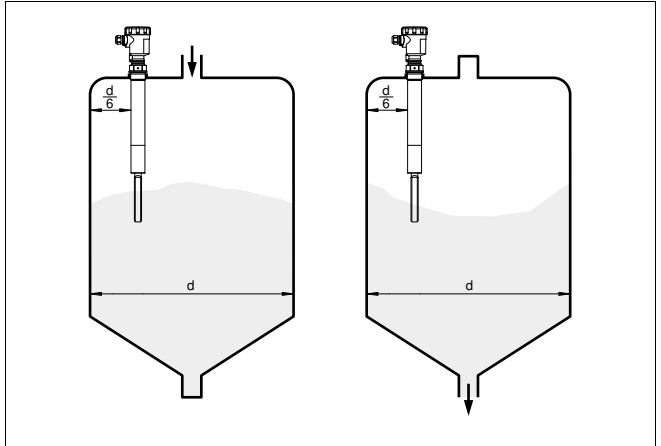

Fig. 4: Filling and emptying centred

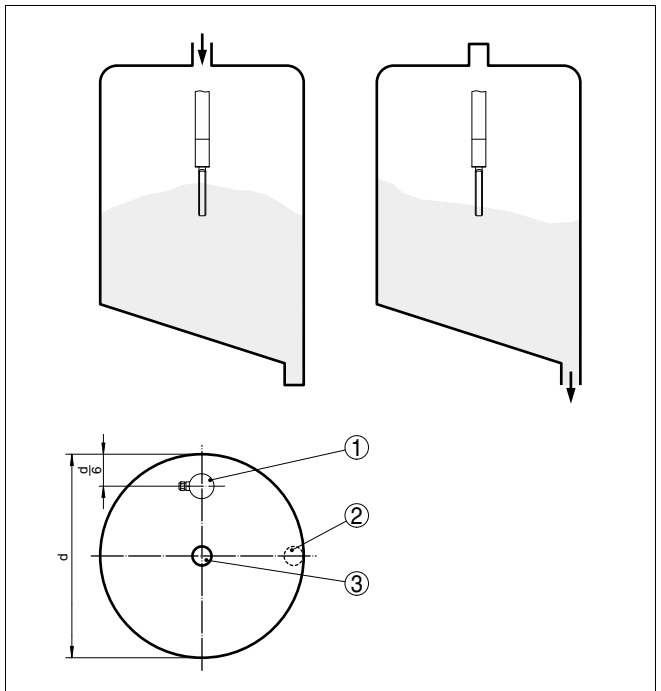

Fig. 5: Filling in the centre, emptying laterally

- 1 LBV 330
- 2 Discharge opening
- 3 Filling opening

**Flows**

To minimise flow resistance caused by the tuning fork, LBV 330 should be mounted in such a way that the surfaces of the blades are parallel to the product movement.

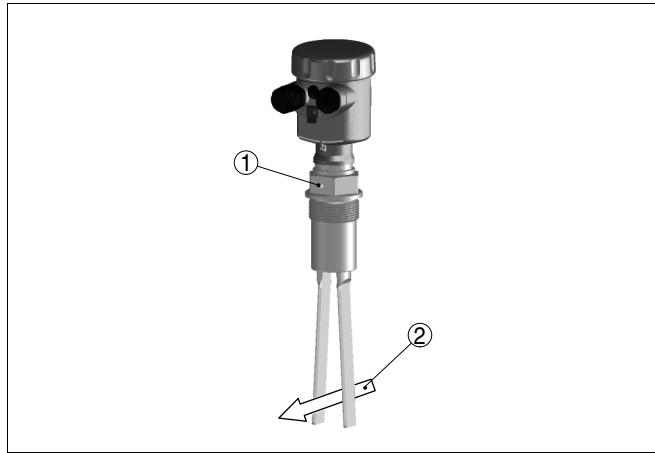

Fig. 6: Flow orientation of the tuning fork

- 1 Marking with screwed version
- 2 Direction of flow

**Baffle protection against falling rocks**

In applications such as grit chambers or settling basins for coarse sediments, the vibrating element must be protected against damage with a suitable baffle.

This baffle must be manufactured by you.

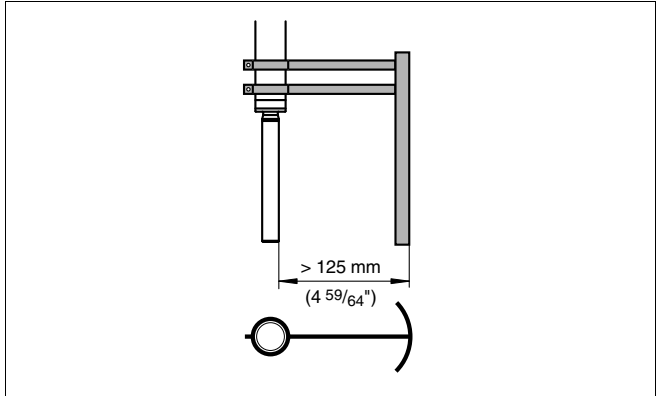

Fig. 7: Baffle for protection against mechanical damage

## 5 Connecting to power supply

### 5.1 Preparing the connection

#### Note safety instructions

Always keep in mind the following safety instructions:

- Connect only in the complete absence of line voltage

#### Take note of safety instructions for Ex applications



In hazardous areas you should take note of the appropriate regulations, conformity and type approval certificates of the sensors and power supply units.

#### Voltage supply

Connect the operating voltage according to the following diagrams. Take note of the general installation regulations. As a rule, connect LBV 330 to vessel ground (PA), or in case of plastic vessels, to the next ground potential. On the side of the instrument housing there is a ground terminal between the cable entries. This connection serves to drain off electrostatic charges. In Ex applications, the installation regulations for hazardous areas must be given priority.

The data for power supply are specified in chapter "*Technical data*".

#### Connection cable

The instrument is connected with standard two-wire cable without screen. If electromagnetic interference is expected which is above the test values of EN 61326 for industrial areas, screened cable should be used.

Use cable with round cross-section. A cable outer diameter of 5 ... 9 mm (0.2 ... 0.35 in) ensures the seal effect of the cable gland. If you are using cable with a different diameter or cross-section, exchange the seal or use a suitable cable gland.

In hazardous areas, only use approved cable connections for LBV 330.

#### Connection cable for Ex applications



Take note of the corresponding installation regulations for Ex applications.

### 5.2 Connection procedure



With Ex instruments, the housing cover may only be opened if there is no explosive atmosphere present.

Proceed as follows:

- 1 Unscrew the housing cover
- 2 Loosen compression nut of the cable entry
- 3 Remove approx. 10 cm (4 in) of the cable mantle, strip approx. 1 cm (0.4 in) of insulation from the ends of the individual wires
- 4 Insert the cable into the sensor through the cable entry



- 5 Lift the opening levers of the terminals with a screwdriver (see following illustration)

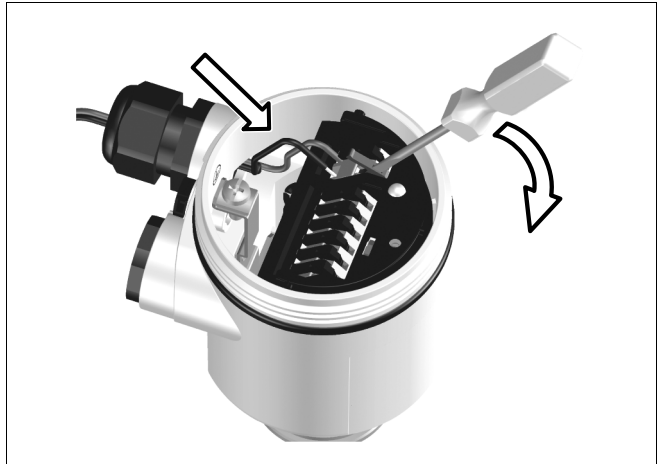

Fig. 8: Connection steps 5 and 6

- 6 Insert the wire ends into the open terminals according to the wiring plan
  - 7 Press down the opening levers of the terminals, you will hear the terminal spring closing
  - 8 Check the hold of the wires in the terminals by lightly pulling on them
  - 9 Tighten the compression nut of the cable entry. The seal ring must completely encircle the cable
  - 10 If necessary, carry out a fresh adjustment
  - 11 Screw the housing cover on
- The electrical connection is finished.

### 5.3 Wiring plan, single chamber housing



The following illustrations apply to the non-Ex as well as to the EEx-d version.

**Housing overview**

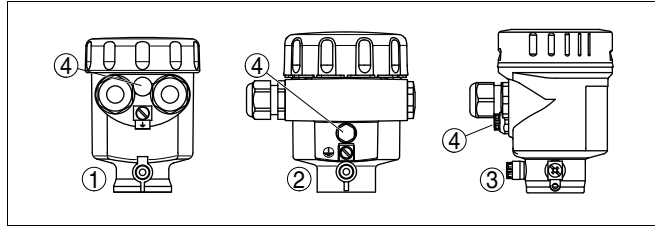

Fig. 9: Material versions, single chamber housing

- 1 Plastic (not with EEx d)
- 2 Aluminium
- 3 Stainless steel, electro-polished
- 4 Filter element for air pressure compensation

**Wiring plan**

We recommend connecting LBV 330 in such a way that the switching circuit is open when there is a level signal, line break or failure (safe condition).

The instrument is used to control relays, contactors, magnet valves, warning lights, horns as well as PLC inputs.



**Caution:**

There is no reverse polarity protection. Take note of the polarity of the output lines.

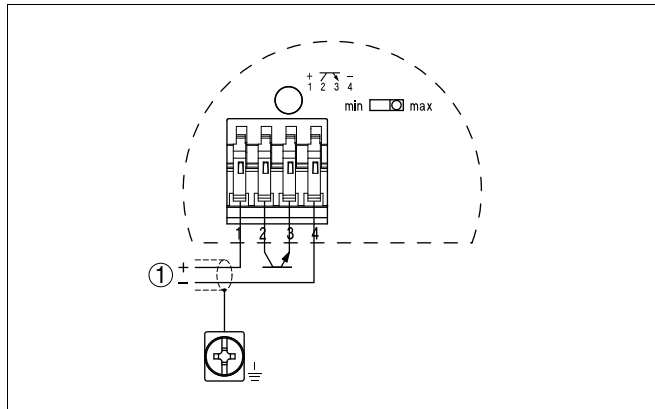
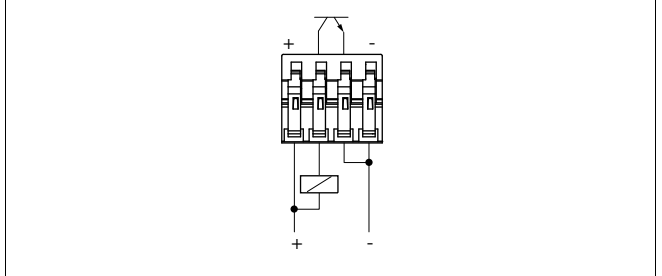
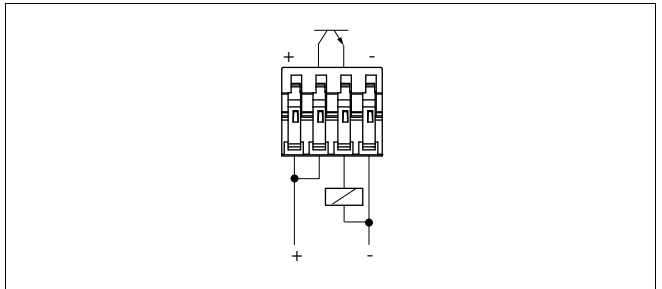

Fig. 10: Wiring plan



*Fig. 11: NPN action*



*Fig. 12: PNP action*

## 6 Set up

### 6.1 In general

The figures in brackets refer to the following illustrations.

#### Function/Configuration

On the electronics module you will find the following indicating and adjustment elements:

- Potentiometer for adaptation to the product density (1)
- DIL switch for mode adjustment - min./max. (2)
- Signal lamp (5)



#### Note:

As a rule, always set the mode with mode switch (2) before starting the setup of LBV 330. The switching output will change if you set the mode switch (2) afterwards. This could possibly trigger other connected instruments or devices.

### 6.2 Adjustment elements

#### Electronics and connection compartment

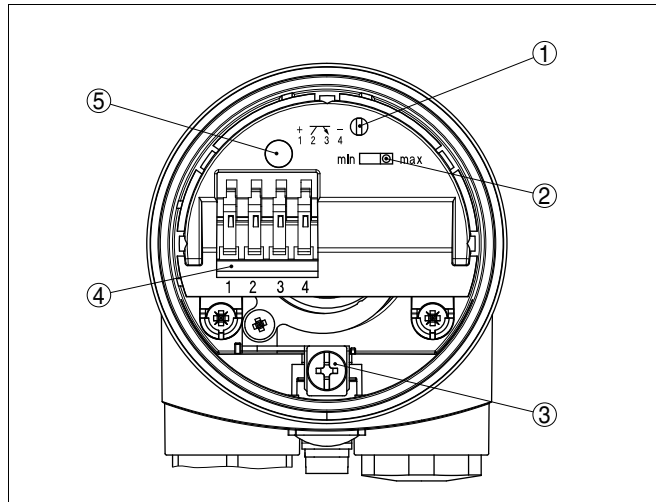

Fig. 13: Electronics and connection compartment - transistor output

- 1 Potentiometer for switching point adaptation
- 2 DIL switch for mode adjustment
- 3 Ground terminal
- 4 Connection terminals
- 5 Control lamp

**Switching point adaptation (1)**

With the potentiometer you can adapt the switching point to the solid. It is already preset and must only be modified in special cases.

By default, the potentiometer of LBV 330 is set to the right stop (> 0.02 g/cm<sup>3</sup> or 0.0008 lbs/in<sup>3</sup>). In case of very light-weight solids, turn the potentiometer to the left stop (> 0.008 g/cm<sup>3</sup> or 0.0003 lbs/in<sup>3</sup>). LBV 330 will thus be more sensitive and can detect light-weight solids more reliably.

**Mode adjustment (2)**

With the mode adjustment (min./max.) you can change the switching condition of the transistor output. You can set the required mode according to the "Function chart" (max. - max. detection or overflow protection, min. - min. detection or dry run protection).

We recommend connecting according to the quiescent current principle (the switching output is open when the switching point is reached) because the transistor output takes on the same (safe) condition if a failure is detected.









**Signal lamp (5)**



Control lamp for indication of the switching status

- green = output conducts
- red = output blocks
- red (flashing) = failure

**6.3 Functional chart**

The following chart provides an overview of the switching conditions depending on the adjusted mode and level.

	Level	Switching status	Control lamp
Mode max. Overflow protection		closed	 Green
Mode max. Overflow protection		open	 Red
Mode min. Dry run protection		closed	 Green
Mode min. Dry run protection		open	 Red

	Level	Switching status	Control lamp
Failure of the supply voltage (min./max. mode)	any	open	
Failure	any	open	 flashes red

## 7 Maintenance and fault rectification

### 7.1 Maintenance

If the instrument is used properly, no special maintenance is required in normal operation.

### 7.2 Rectify faults

#### Reaction when malfunctions occur

The operator of the system is responsible for taking suitable measures to remove interferences.

#### Failure reasons

LBV 330 offers maximum reliability. Nevertheless, faults can occur during operation. These may be caused by the following, e.g.:

- Sensor
- Process
- Voltage supply
- Signal processing

#### Fault rectification

The first measure to be taken is to check the output signal. In many cases, the causes can be determined this way and the faults rectified.

#### Checking the switching signal

Error	Cause	Removal
LBV 330 signals "covered" when the vibrating element is not submerged (overflow protection) LBV 330 signals "uncovered" when the vibrating element is submerged (dry run protection)	Operating voltage too low	Check operating voltage
	Electronics defective	Press the mode switch. If the instrument then changes the mode, the vibrating element may be covered with buildup or mechanically damaged. Should the switching function in the correct mode still be faulty, return the instrument for repair.
		Press the mode switch. If the instrument then does not change the mode, the electronics module is defective. Exchange the electronics module.
	Unfavourable installation location	Mount the instrument at a location in the vessel where no dead zones or mounds can form.
Buildup on the vibrating element	Check the vibrating element and the sensor if there is buildup and remove it.	

Error	Cause	Removal
	Wrong mode selected	Set the correct mode on the mode switch (overflow protection, dry run protection). Wiring should be carried out according to the quiescent current principle.
Signal lamp flashes red	Error on the vibrating element	Check if the vibrating element is damage or extremely corroded.
	Interference on the electronics module	Exchanging the electronics module
	instrument defective	Exchange the instrument or send it in for repair

### Reaction after fault rectification

Depending on the failure reason and measures taken, the steps described in chapter "Set up" must be carried out again, if necessary.

## 7.3 Exchanging the electronics module

In general, all electronics modules of series WE60 can be interchanged. If you want to use an electronics module with a different signal output, you can download the corresponding operating instructions manual from our homepage under Downloads.



With EEx d instruments, the housing cover may only be opened if there is no explosive atmosphere present.

Proceed as follows:

- 1 Switch off power supply
- 2 Unscrew the housing cover
- 3 Lift the opening levers of the terminals with a screwdriver
- 4 Pull the connection cables out of the terminals
- 5 Loosen the two screws with a screw driver (Torx size T10 or slot 4)



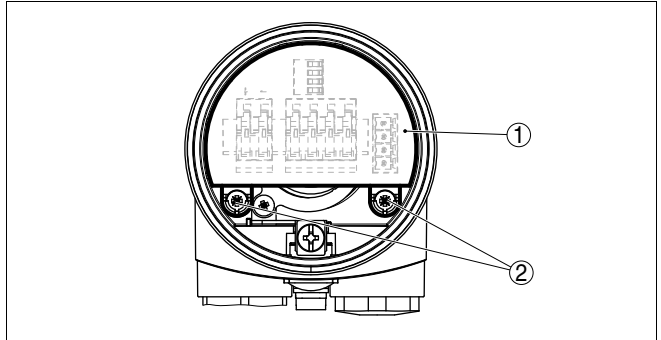

Fig. 24: Loosening the holding screws

- 1 Electronics module
- 2 Screws (2 pcs.)

- 6 Pull out the old electronics module
- 7 Compare the new electronics module with the old one. The type label of the electronics module must correspond to that of the old electronics module. This applies particularly to instruments used in hazardous areas.
- 8 Compare the settings of the two electronics modules. Set the adjustment elements of the new electronics module to the same setting of the old one.



**Information:**

Make sure that the housing is not rotated during the electronics exchange. Otherwise the plug may be in a different position later.

- 9 Insert the electronics module carefully. Make sure that the plug is in the correct position.
  - 10 Screw in and tighten the two holding screws with a screwdriver (Torx size T10 or Phillips 4)
  - 11 Insert the wire ends into the open terminals according to the wiring plan
  - 12 Press down the opening levers of the terminals, you will hear the terminal spring closing
  - 13 Check the hold of the wires in the terminals by lightly pulling on them
  - 14 Check cable gland on tightness. The seal ring must completely encircle the cable.
  - 15 Screw the housing cover on
- The electronics exchange is now finished.

## **7.4 Instrument repair**

If it is necessary to repair the instrument, please contact the responsible Sick agency.

## 8 Dismounting

### 8.1 Dismounting steps



**Warning:**

Before dismounting, be aware of dangerous process conditions such as e.g. pressure in the vessel, high temperatures, corrosive or toxic products etc.

Take note of chapters "*Mounting*" and "*Connecting to power supply*" and carry out the listed steps in reverse order.



With Ex instruments, the housing cover may only be opened if there is no explosive atmosphere present.

### 8.2 Disposal

The instrument consists of materials which can be recycled by specialised recycling companies. We use recyclable materials and have designed the electronics to be easily separable.

**WEEE directive 2002/96/EG**

This instrument is not subject to the WEEE directive 2002/96/EG and the respective national laws. Pass the instrument directly on to a specialised recycling company and do not use the municipal collecting points. These may be used only for privately used products according to the WEEE directive.

Correct disposal avoids negative effects to persons and environment and ensures recycling of useful raw materials.

Materials: see chapter "*Technical data*"

If you have no way to dispose of the old instrument properly, please contact us concerning return and disposal.

## 9 Supplement

### 9.1 Technical data

#### General data

---

Material 316L corresponds to 1.4404 or 1.4435

#### Materials, wetted parts

– Process fitting - thread	316L
– Process fitting - flange	316L
– Process seal	Klingersil C-4400
– Tuning fork	316L
– Extension tube ø 43 mm (1.7 in)	316L

#### Materials, non-wetted parts

– Plastic housing	plastic PBT (Polyester)
– Aluminium die-casting housing	Aluminium die-casting AlSi10Mg, powder-coated - basis: Polyester
– Stainless steel housing, electropolished	316L
– Seal between housing and housing cover	NBR (stainless steel housing), silicone (Alu/plastic housing)
– Light guide in housing cover (plastic)	PMMA (Makrolon)
– Ground terminal	316L

#### Process fittings

– Pipe thread, cylindrical (DIN 3852-A)	G1½ A
– American pipe thread, conical (ASME B1.20.1)	1½ NPT

#### Weight approx.

– Instrument weight (depending on process fitting)	0.8 ... 4 kg (0.18 ... 8.82 lbs)
– Extension tube	2000 g/m (21.5 oz/ft)

Sensor length (L) 0.3 ... 6 m (0.984 ... 19.69 ft)

Max. lateral load 290 Nm, max. 600 N (214 lbf ft, max. 135 lbf)

#### Output variable

---

Output	Floating transistor output, permanently shortcircuit-proof
Load current	< 400 mA
Turn-on voltage	< 55 V DC
Blocking current	< 100 µA
Modes (adjustable)	min./max.
Switching delay	
– When immersed	0.5 s

- When laid bare 1 s

**Ambient conditions**

Ambient temperature on the housing	-40 ... +80 °C (-40 ... +176 °F)
Storage and transport temperature	-40 ... +80 °C (-40 ... +176 °F)

**Process conditions**

Measured variable	Limit level of solids
Process pressure	-1 ... 25 bar/-100 ... 2500 kPa (-14.5 ... 363 psig)
LBV 330 of 316L	-50 ... +150 °C (-58 ... +302 °F)
Process temperature (thread or flange temperature) with temperature adapter (option)	-50 ... +250 °C (-58 ... +482 °F)

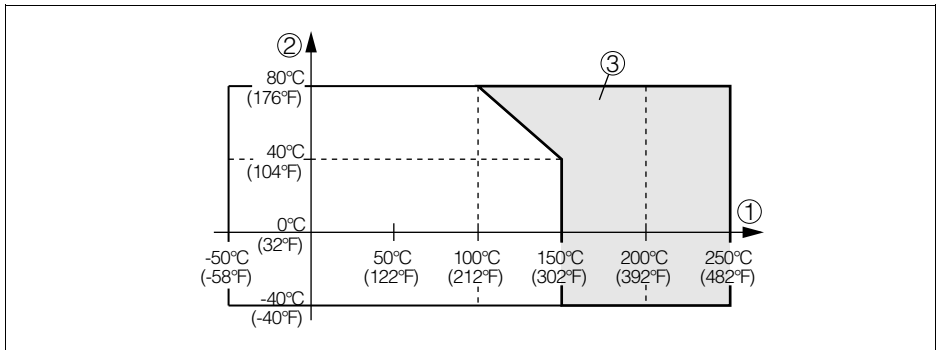

Fig. 25: Ambient temperature - Process temperature

- 1 Process temperature
- 2 Ambient temperature
- 3 Temperature range with temperature adapter

**Product density**

- Standard > 0.02 g/cm<sup>3</sup> (0.0007 lbs/in<sup>3</sup>)
- adjustable > 0.008 g/cm<sup>3</sup> (0.0003 lbs/in<sup>3</sup>)

**Granular size**

max. 10 mm (0.4 in)

**Electromechanical data - version IP 66/IP 67 and IP 66/IP 68; 0.2 bar**

**Cable entry/plug<sup>1)</sup>**

- Single chamber housing
    - 1 x cable gland M20 x 1.5 (cable: ø 5 ... 9 mm), 1 x blind stopper M20 x 1.5
- or:

<sup>1)</sup> Depending on the version M12 x 1, according to ISO 4400, Harting, 7/8" FF.

- 1 x closing cap ½ NPT, 1 x blind plug ½ NPT
- or:
- 1 x plug (depending on the version), 1 x blind stopper M20 x 1.5

Spring-loaded terminals

for wire cross-section up to 1.5 mm<sup>2</sup> (AWG 16)

---

### Adjustment elements

---

Mode switch

- |        |                                       |
|--------|---------------------------------------|
| – Min. | Min. detection or dry run protection  |
| – Max. | Max. detection or overflow protection |

---

### Voltage supply

---

Operating voltage	10 ... 55 V DC
Power consumption	max. 0.5 W

---

### Electrical protective measures

---

Protection rating

- |                     |                                     |
|---------------------|-------------------------------------|
| – Plastic housing   | IP 66/IP 67                         |
| – Aluminium housing | IP 66/IP 68 (0.2 bar) <sup>2)</sup> |

Overvoltage category III

Protection class II

---

### Approvals

---

Depending on the version, instruments with approvals can have different technical data. For these instruments, please note the corresponding approval documents. They are included in the scope of delivery.

<sup>2)</sup> A suitable cable is the prerequisite for maintaining the protection rating.

## 9.2 Dimensions

### LBV 330

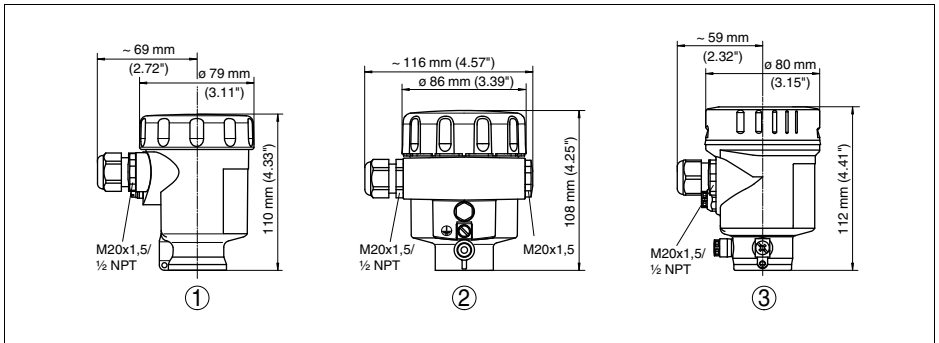

Fig. 26: Housing versions

- 1 Plastic housing
- 2 Aluminium housing
- 3 Stainless steel housing, electropolished

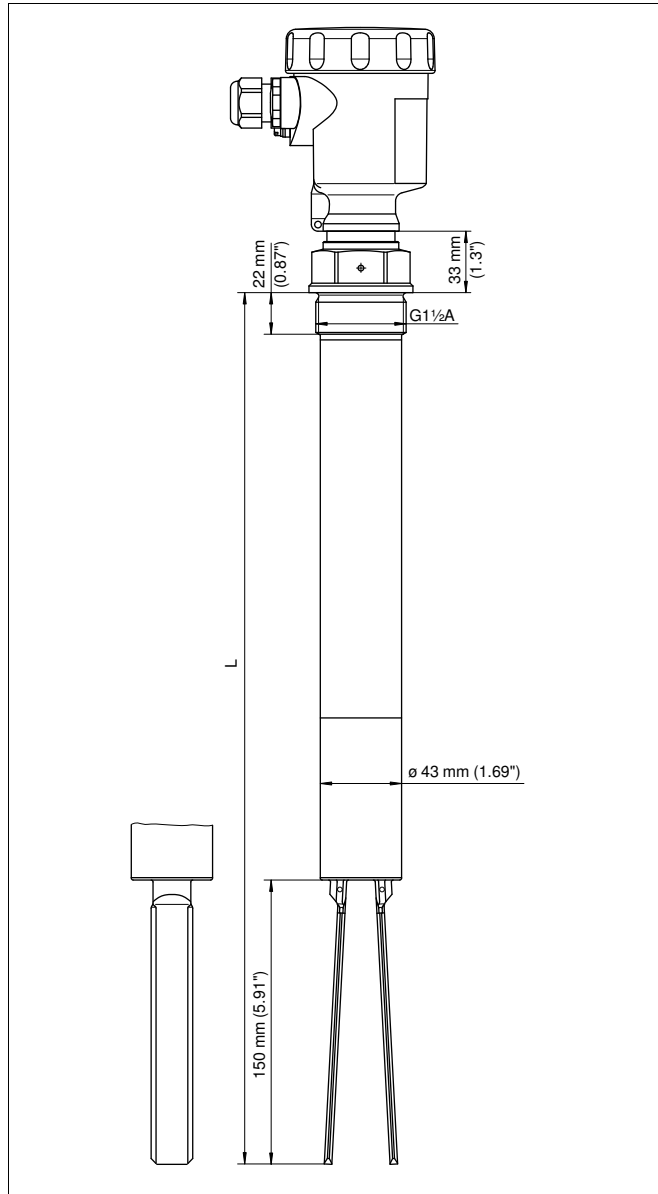
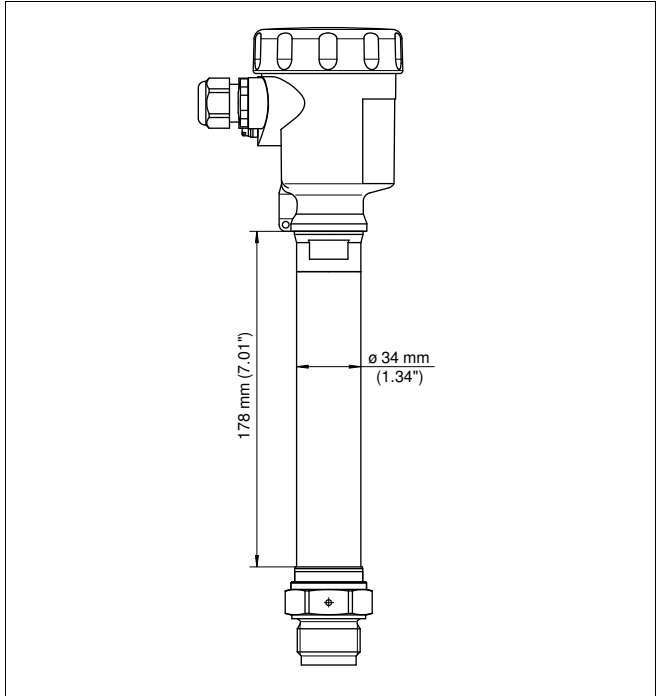

Fig. 27: LBV 330 - threaded version G1½ A (DIN ISO 228/1)

$L$  Sensor length, see chapter "Technical data"





*Fig. 28: Temperature adapter*





Australia  
Phone +61 3 9497 4100  
1800 33 48 02 – tollfree  
E-Mail sales@sick.com.au

Belgium/Luxembourg  
Phone +32 (0)2 466 55 66  
E-Mail info@sick.be

Brasil  
Phone +55 11 3215-4900  
E-Mail sac@sick.com.br

Ceská Republika  
Phone +420 2 57 91 18 50  
E-Mail sick@sick.cz

China  
Phone +852-2763 6966  
E-Mail ghk@sick.com.hk

Danmark  
Phone +45 45 82 64 00  
E-Mail sick@sick.dk

Deutschland  
Phone +49 211 5301-301  
E-Mail info@sick.de

España  
Phone +34 93 480 31 00  
E-Mail info@sick.es

France  
Phone +33 1 64 62 35 00  
E-Mail info@sick.fr

Great Britain  
Phone +44 (0)1727 831121  
E-Mail info@sick.co.uk

India  
Phone +91-22-4033 8333  
E-Mail info@sick-india.com

Israel  
Phone +972-4-999-0590  
E-Mail info@sick-sensors.com

Italia  
Phone +39 02 27 43 41  
E-Mail info@sick.it

Japan  
Phone +81 (0)3 3358 1341  
E-Mail support@sick.jp

Nederlands  
Phone +31 (0)30 229 25 44  
E-Mail info@sick.nl

Norge  
Phone +47 67 81 50 00  
E-Mail austefjord@sick.no

Österreich  
Phone +43 (0)22 36 62 28 8-0  
E-Mail office@sick.at

Polska  
Phone +48 22 837 40 50  
E-Mail info@sick.pl

Republic of Korea  
Phone +82-2 786 6321/4  
E-Mail kang@sickkorea.net

Republika Slovenija  
Phone +386 (0)1-47 69 990  
E-Mail office@sick.si

România  
Phone +40 356 171 120  
E-Mail office@sick.ro

Russia  
Phone +7 495 775 05 34  
E-Mail info@sick-automation.ru

Schweiz  
Phone +41 41 619 29 39  
E-Mail contact@sick.ch

Singapore  
Phone +65 6744 3732  
E-Mail admin@sicksgp.com.sg

Suomi  
Phone +358-9-25 15 800  
E-Mail sick@sick.fi

Sverige  
Phone +46 10 110 10 00  
E-Mail info@sick.se

Taiwan  
Phone +886 2 2365-6292  
E-Mail sickgrc@ms6.hinet.net

Türkiye  
Phone +90 216 587 74 00  
E-Mail info@sick.com.tr

USA/Canada/México  
Phone +1(952) 941-6780  
1800-325-7425 – tollfree  
E-Mail info@sickusa.com

More representatives and agencies in all major industrial nations at [www.sick.com](http://www.sick.com)

**SICK**  
Sensor Intelligence.