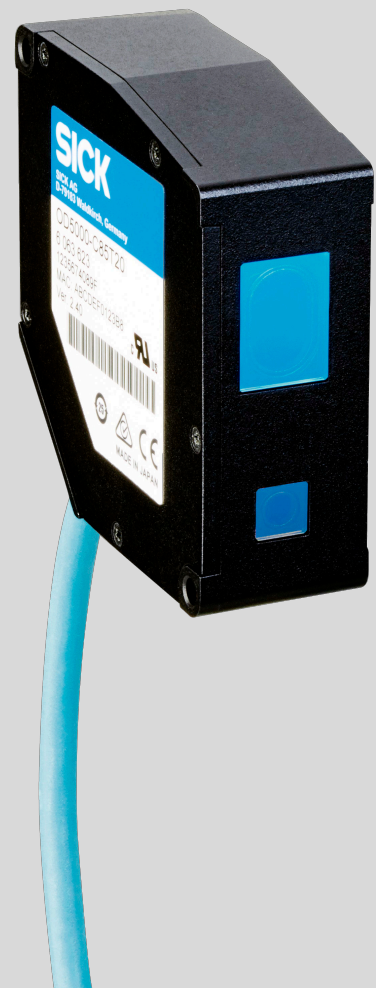


OD5000

Displacement measurement sensor

SICK
Sensor Intelligence.



Product described

OD5000

Manufacturer

SICK AG
Erwin-Sick-Str. 1
79183 Waldkirch
Germany

Legal information

This work is protected by copyright. Any rights derived from the copyright shall be reserved for SICK AG. Reproduction of this document or parts of this document is only permissible within the limits of the legal determination of Copyright Law. Any modification, abridgment or translation of this document is prohibited without the express written permission of SICK AG.

The trademarks stated in this document are the property of their respective owner.

© SICK AG. All rights reserved.

Original document

This document is an original document of SICK AG.



Contents

1	About this document.....	7
1.1	Information on the operating instructions.....	7
1.2	Explanation of symbols.....	7
1.3	SICK service.....	7
2	Safety information.....	8
2.1	Intended use.....	8
2.2	Improper use.....	8
2.3	Limitation of liability.....	8
2.4	Modifications and conversions.....	8
2.5	Requirements for skilled persons and operating personnel.....	9
2.6	Operational safety and particular hazards.....	9
2.6.1	Laser radiation.....	10
2.7	Warning signs on the device.....	10
3	Product description.....	11
3.1	Product characteristics.....	11
3.2	Setup and dimensions.....	11
3.2.1	Light spot size.....	14
3.3	Product identification.....	18
4	Transport and storage.....	20
4.1	Transport.....	20
4.2	Unpacking.....	20
4.3	Transport inspection.....	20
4.4	Storage.....	20
5	Mounting.....	21
5.1	Scope of delivery.....	21
5.2	Facilities for connecting.....	22
5.3	Mounting instructions.....	23
5.4	Mounting device.....	23
5.4.1	Mounting the device depending on application.....	24
6	Electrical installation.....	27
6.1	Safety.....	27
6.2	Wiring notes.....	27
6.3	Pin assignment of the connections.....	27
6.4	Connecting the device electrically.....	30
7	Operation.....	31
7.1	General notes.....	31
7.2	Control elements and status indicators.....	31
7.2.1	Indicator lights.....	31
7.2.2	Operating elements.....	32

7.3	Operation via web browser (SOPASair).....	32
7.3.1	Determining the device IP address.....	32
7.3.2	Connecting via the web browser.....	32
7.3.3	Overview of SOPASair.....	34
7.3.4	Monitoring.....	35
7.3.5	Measurement.....	35
7.3.5.1	Setting diffuse or specular reflection.....	36
7.3.5.2	Determining the measurement type.....	36
7.3.5.3	Teaching in the zero point.....	37
7.3.5.4	Setting the sampling duration.....	38
7.3.5.5	Synchronizing several OD5000 sensors.....	39
7.3.5.6	Determining the direction of detection.....	39
7.3.5.7	Checking the light distribution curve and peaks..	40
7.3.6	Settings for channels A–D.....	41
7.3.6.1	Setting the measurement value filter.....	41
7.3.6.2	Setting the Hold function.....	43
7.3.6.3	Mismeasurement behavior.....	46
7.3.7	I/O channels.....	47
7.3.7.1	Setting ObSB switching mode.....	48
7.3.7.2	Setting DtO switching mode.....	48
7.3.7.3	Setting Window switching mode.....	48
7.3.7.4	Setting edge height change switching mode.....	48
7.3.7.5	Setting limits.....	49
7.3.7.6	Setting the hysteresis.....	50
7.3.7.7	Setting the switch-on delay (on delay).....	50
7.3.7.8	Setting the switch-off delay (Off Delay).....	51
7.3.7.9	Setting the calibration.....	51
7.3.7.10	Setting One shot.....	53
7.3.8	I/O settings input (MF).....	54
7.3.8.1	Setting the polarity.....	54
7.3.8.2	Setting the switching function.....	54
7.3.8.3	Setting the debounce.....	55
7.3.9	Device.....	55
7.3.9.1	Deactivating the measurement laser.....	55
7.3.9.2	Resetting the device to factory settings.....	55
7.3.9.3	Setting the sensor time.....	55
7.3.9.4	Device identification (find me).....	55
7.3.9.5	Saving the configuration.....	55
7.3.9.6	Loading the configuration.....	56
7.3.10	Communication.....	56
7.3.10.1	Communication settings.....	56
7.3.10.2	Network settings.....	57
7.3.11	Recording.....	58
7.3.11.1	Formatting settings.....	58
7.3.11.2	Starting and testing the recording.....	58

7.3.11.3	Determining the allocation.....	58
7.3.11.4	Setting the interval.....	59
7.3.11.5	Setting the start conditions.....	59
7.3.11.6	Defining the threshold.....	59
7.3.11.7	Defining the trigger channel.....	59
7.3.11.8	Setting the start position.....	59
7.3.11.9	View process.....	60
7.3.12	Info.....	60
7.3.13	Expert.....	61
7.3.14	Settings.....	61
7.3.14.1	Selecting a language.....	61
7.3.14.2	Selecting the display mode.....	61
7.4	Operation via Ethernet.....	61
7.4.1	Reading and writing data.....	62
7.4.2	Command list.....	63
7.4.2.1	Outputting measured values.....	63
7.4.3	Measurement.....	65
7.4.3.1	Selecting default settings.....	65
7.4.3.2	Making the settings for channels A-D.....	67
7.4.4	I/O settings.....	69
7.4.4.1	Configuring channels A-D.....	69
7.4.4.2	Configuring MF input.....	71
7.4.5	Device settings.....	71
7.4.6	Communication.....	72
7.4.7	Saving data.....	72
7.4.8	Info.....	73
7.4.9	Determining measured values using time specifications.....	73
7.4.10	Obtaining data continuously.....	73
7.4.11	Error messages.....	76
8	Maintenance.....	77
8.1	Maintenance.....	77
8.2	Cleaning.....	77
9	Troubleshooting.....	78
9.1	General faults, warnings, and errors.....	78
9.2	Detecting and displaying errors.....	78
9.3	Information for service cases.....	79
9.4	Returns.....	79
9.5	Repairs.....	79
10	Decommissioning.....	80
10.1	Disposal.....	80
11	Technical data.....	81
11.1	Performance.....	81

11.2	Interfaces.....	83
11.3	Mechanics and electronics.....	83
11.4	Ambient data.....	83
11.5	Linearity diagram.....	84
12	Accessories.....	87
12.1	Recommended accessories.....	87
13	Annex.....	88
13.1	EU declaration of conformity / Certificates.....	88
13.2	Licenses.....	88

1 About this document

1.1 Information on the operating instructions

These operating instructions provide important information on how to handle the product from SICK AG. Adherence to all the specified safety notes and guidelines is a prerequisite for working safely. You must also comply with any local work safety regulations and general safety specifications applicable to the use of the product.

Ensure that you read through these operating instructions carefully before starting any work. They constitute an integral part of the product and should be stored in the direct vicinity of the product so they remain accessible to personnel at all times. If the product is passed on to a third party, these operating instructions should be handed over with it.

These operating instructions do not provide information on operating the machine in which the product is integrated. For information about this, refer to the operating instructions of the particular machine.

1.2 Explanation of symbols

Warnings and important information in this document are labeled with symbols. The warnings are introduced by signal words that indicate the extent of the danger. These warnings must be observed at all times and care must be taken to avoid accidents, personal injury, and material damage.



DANGER

... indicates a situation of imminent danger, which will lead to a fatality or serious injuries if not prevented.



WARNING

... indicates a potentially dangerous situation, which may lead to a fatality or serious injuries if not prevented.



CAUTION

... indicates a potentially dangerous situation, which may lead to minor/slight injuries if not prevented.



NOTICE

... indicates a potentially harmful situation, which may lead to material damage if not prevented.



NOTE

... highlights useful tips and recommendations as well as information for efficient and trouble-free operation.

1.3 SICK service

If you require any technical information, our SICK Service will be happy to help. To find your agency, see the final page of this document.



NOTE

Before calling, make a note of all type label data such as type code, serial number, etc., to ensure faster processing.

2 Safety information

2.1 Intended use

The displacement measurement sensor is an opto-electronic measuring device and is used for optical, non-contact distance measurement of objects.

The required optical properties of the object that will be detected are specified in the technical data section of this document.

SICK AG assumes no liability for losses or damage arising from the use of the product, either directly or indirectly. This applies in particular to use of the product that does not conform to its intended purpose and is not described in this documentation.

2.2 Improper use

Any use outside of the stated areas, in particular use outside of the technical specifications and the requirements for intended use, will be deemed to be incorrect use.

- The device does not constitute a safety component in accordance with the respective applicable safety standards for machines.
- The device must not be used in explosion-hazardous areas, in corrosive environments or under extreme environmental conditions.
- Any use of accessories not specifically approved by SICK AG is at your own risk.



WARNING

Danger due to improper use!

Any improper use can result in dangerous situations.

Therefore, observe the following information:

- Device should be used only in accordance with its intended use.
 - All information in these operating instructions must be strictly observed.
-

2.3 Limitation of liability

Applicable standards and regulations, the latest state of technological development, and our many years of knowledge and experience have all been taken into account when assembling the data and information contained in these operating instructions. The manufacturer accepts no liability for damage caused by:

- Failing to observe the operating instructions
- Incorrect use
- Use by untrained personnel
- Unauthorized conversions
- Technical modifications
- Use of unauthorized spare parts, consumables, and accessories

With special variants, where optional extras have been ordered, or owing to the latest technical changes, the actual scope of delivery may vary from the features and illustrations shown here.

2.4 Modifications and conversions



NOTICE

Modifications and conversions to the device may result in unforeseeable dangers.

Interrupting or modifying the device or SICK software will invalidate any warranty claims against SICK AG. This applies in particular to opening the housing, even as part of mounting and electrical installation.

2.5 Requirements for skilled persons and operating personnel



WARNING

Risk of injury due to insufficient training.

Improper handling of the device may result in considerable personal injury and material damage.

- All work must only ever be carried out by the stipulated persons.

The operating instructions state the following qualification requirements for the various areas of work:

- **Instructed personnel** have been briefed by the operator about the tasks assigned to them and about potential dangers arising from improper action.
- **Skilled personnel** have the specialist training, skills, and experience, as well as knowledge of the relevant regulations, to be able to perform tasks delegated to them and to detect and avoid any potential dangers independently.
- **Electricians** have the specialist training, skills, and experience, as well as knowledge of the relevant standards and provisions to be able to carry out work on electrical systems and to detect and avoid any potential dangers independently. In Germany, electricians must meet the specifications of the BGV A3 Work Safety Regulations (e.g. Master Electrician). Other relevant regulations applicable in other countries must be observed.

The following qualifications are required for various activities:

Table 1: Activities and technical requirements

Activities	Qualification
Mounting, maintenance	<ul style="list-style-type: none"> ■ Basic practical technical training ■ Knowledge of the current safety regulations in the workplace
Electrical installation, device replacement	<ul style="list-style-type: none"> ■ Practical electrical training ■ Knowledge of current electrical safety regulations ■ Knowledge of the operation and control of the devices in their particular application
Commissioning, configuration	<ul style="list-style-type: none"> ■ Basic knowledge of the Windows™ operating system in use ■ Basic knowledge of the design and setup of the described connections and interfaces ■ Basic knowledge of data transmission
Operation of the device for the particular application	<ul style="list-style-type: none"> ■ Knowledge of the operation and control of the devices in their particular application ■ Knowledge of the software and hardware environment for the particular application

2.6 Operational safety and particular hazards

Please observe the safety notes and the warnings listed here and in other chapters of these operating instructions to reduce the possibility of risks to health and avoid dangerous situations.



CAUTION

Optical radiation: Laser class 1

The accessible radiation does not pose a danger when viewed directly for up to 100 seconds. It may pose a danger to the eyes and skin in the event of incorrect use.

- Do not open the housing. Opening the housing may increase the level of risk.
 - Current national regulations regarding laser protection must be observed.
-



WARNING

Electrical voltage!

Electrical voltage can cause severe injury or death.

- Work on electrical systems must only be performed by qualified electricians.
 - The power supply must be disconnected when attaching and detaching electrical connections.
 - The sensor must only be connected to a voltage source as set out in the requirements in the operating instructions.
 - National and regional regulations must be complied with.
 - Safety requirements relating to work on electrical systems must be complied with.
-



WARNING

Dangerous equipotential bonding currents!

Improper grounding can lead to dangerous equipotential bonding currents, which may in turn lead to dangerous voltages on metallic surfaces, such as the housing. Electrical voltage can cause severe injury or death.

- Work on electrical systems must only be performed by qualified electricians.
 - Follow the notes in the operating instructions.
 - Install the grounding for the sensor and the system in accordance with national and regional regulations.
-

2.6.1 Laser radiation

The device is equipped with a laser source:

- Measurement laser (red, visible to the human eye)
-



CAUTION

Optical radiation: Laser class 1

The accessible radiation does not pose a danger when viewed directly for up to 100 seconds. It may pose a danger to the eyes and skin in the event of incorrect use.

- Do not open the housing. Opening the housing may increase the level of risk.
 - Current national regulations regarding laser protection must be observed.
-

The laser qualifies as a class 1 laser based on standard IEC 60825-1: 2014 (Safety of laser products - Part 1: Equipment classification and requirements, Edition 3).

2.7 Warning signs on the device

A visible red laser is installed in the device. The laser corresponds to laser class 1 based on IEC 60825-1:2007 (second edition) and IEC 60825-1:2014 (third edition). The housing is labeled with a warning sign.

3 Product description

3.1 Product characteristics

The displacement measurement sensor uses the triangulation principle for distance measurement. This technology makes it possible to measure the distance between the displacement measurement sensor and an object.

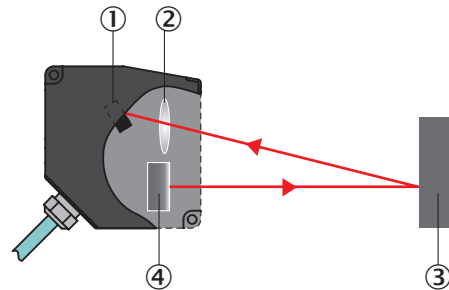


Figure 1: Triangulation principle

- ① Receiver
- ② Lens
- ③ Object
- ④ Laser

A point of light is projected onto the measuring object. The light reflected is captured by a light-sensitive receiver at a specific angle. Based on the angle between the send and receive direction, the position of the object is triangulated (lat. Triangulum: triangle).

The displacement measurement sensor can be configured via the SOPASair user interface. For more information visit:

► www.sick.com/SOPASair

3.2 Setup and dimensions

All measurements in mm (inch).

OD5000-C15xxx

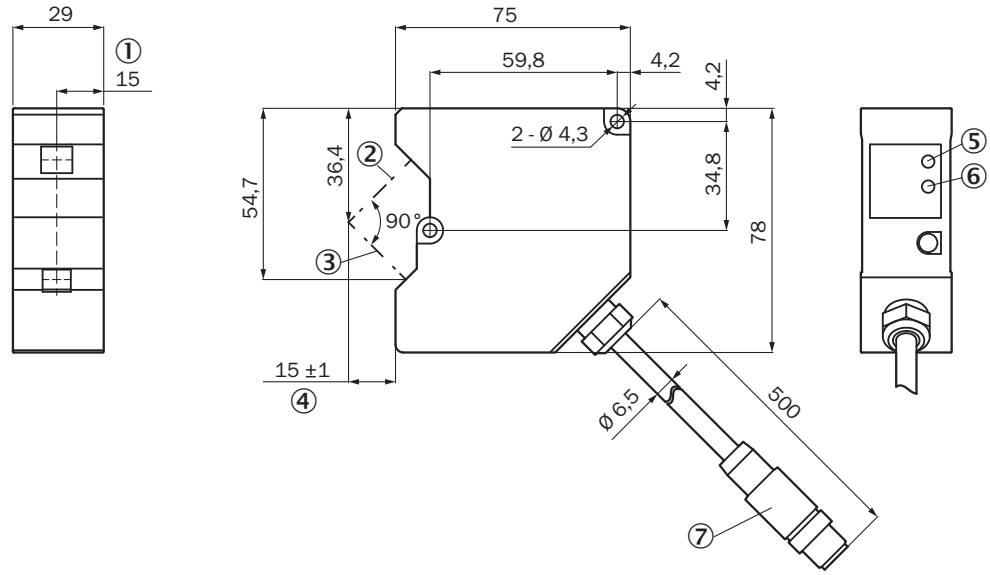


Figure 2: Setup and dimensions of OD5000-C15xxx

- ① Reference plane
- ② Optical axis, receiver
- ③ Optical axis, sender
- ④ Measuring range
- ⑤ Link LED
- ⑥ Status LED
- ⑦ Plug connector, M12, 8-pin

OD5000-C30xxx

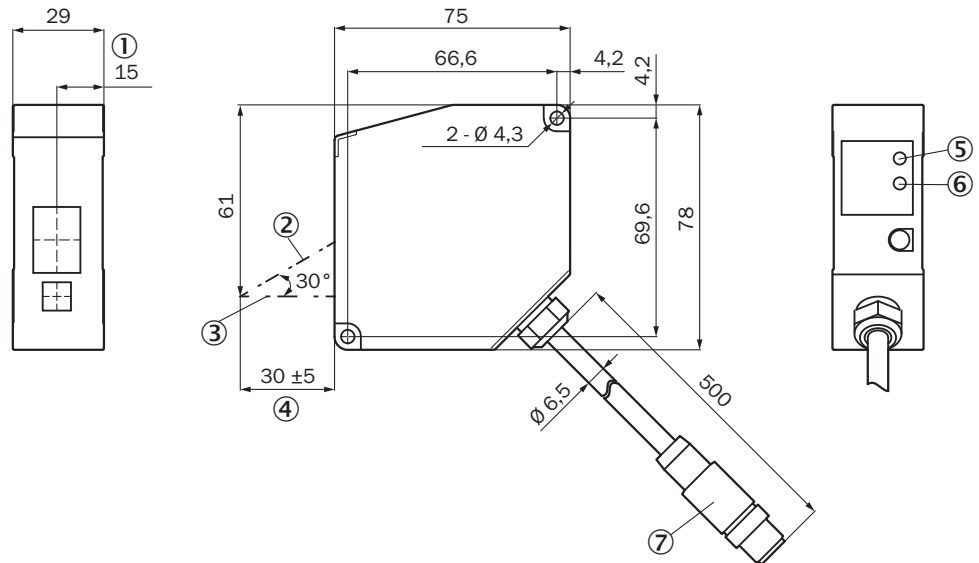


Figure 3: Setup and dimensions of OD5000-C30xxx

- ① Reference plane
- ② Optical axis, receiver
- ③ Optical axis, sender
- ④ Measuring range
- ⑤ Link LED

- ⑥ Status LED
- ⑦ Plug connector, M12, 8-pin

OD5000-C85xxx

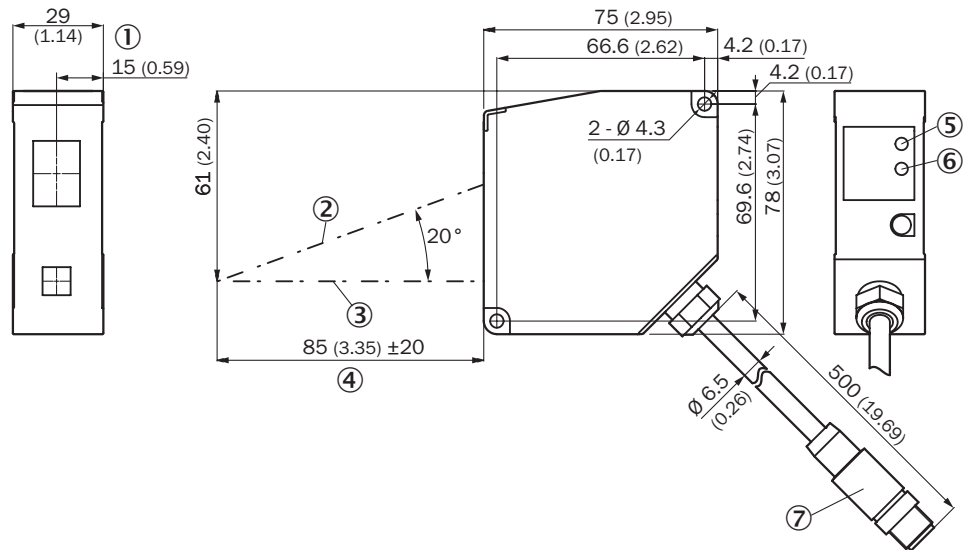


Figure 4: Setup and dimensions of OD5000-C85xxx

- ① Reference plane
- ② Optical axis, receiver
- ③ Optical axis, sender
- ④ Measuring range
- ⑤ Link LED
- ⑥ Status LED
- ⑦ Plug connector, M12, 8-pin

OD5000-C150xxx

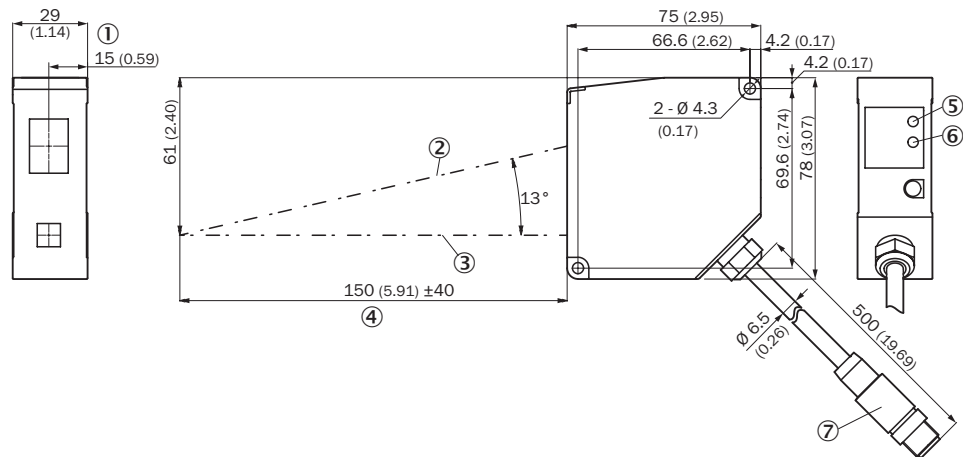


Figure 5: Setup and dimensions of OD5000-C150xxx

- ① Reference plane
- ② Optical axis of the receiver
- ③ Optical axis of the sender
- ④ Measuring range
- ⑤ Link LED
- ⑥ Status LED

- ⑦ Plug connector, M12, 8-pin

Y-distribution

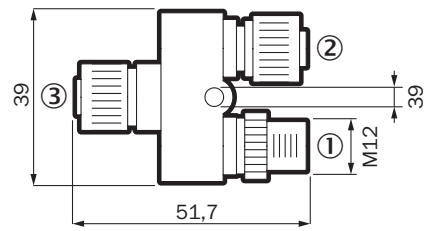


Figure 6: Setup and dimensions of Y-adapter

- ① M12, 4-pin, A-coded
- ② M12, 5-pin, D-coded
- ③ M12, 8-pin, A-coded

3.2.1 Light spot size

OD5000-C15T01

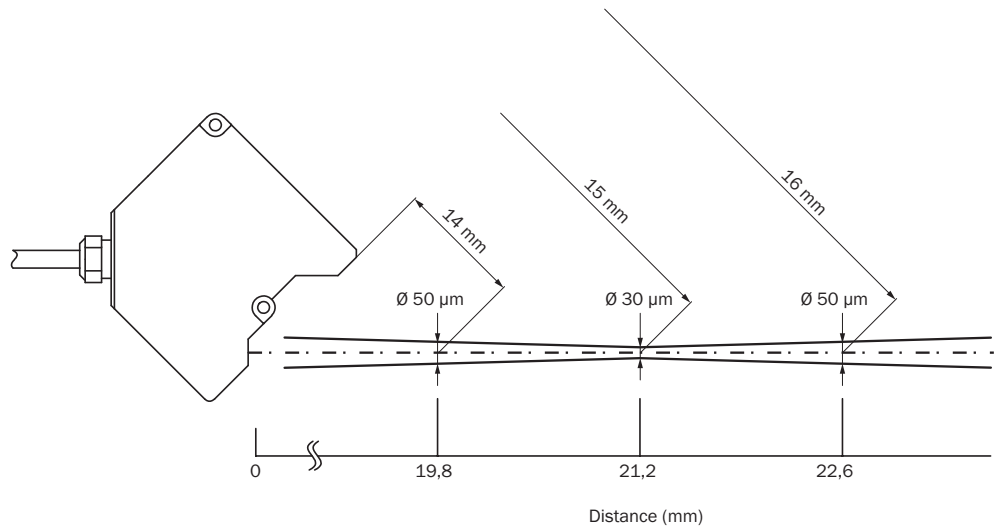


Figure 7: Typical light spot size of OD5000-C15T01

OD5000-C15W01

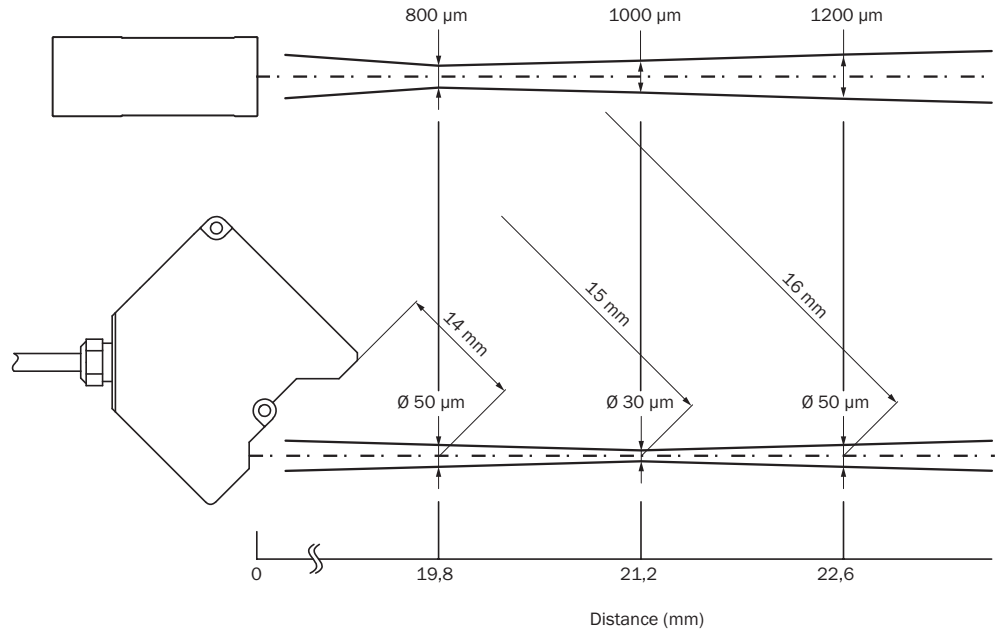


Figure 8: Typical light spot size of OD5000-C15W01

OD5000-C30T05

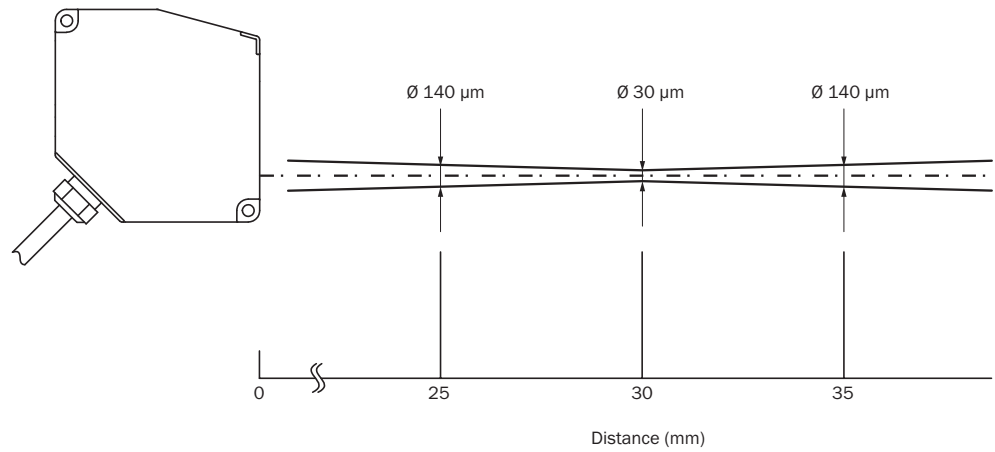


Figure 9: Typical light spot size of OD5000-C30T05

OD5000-C30W05

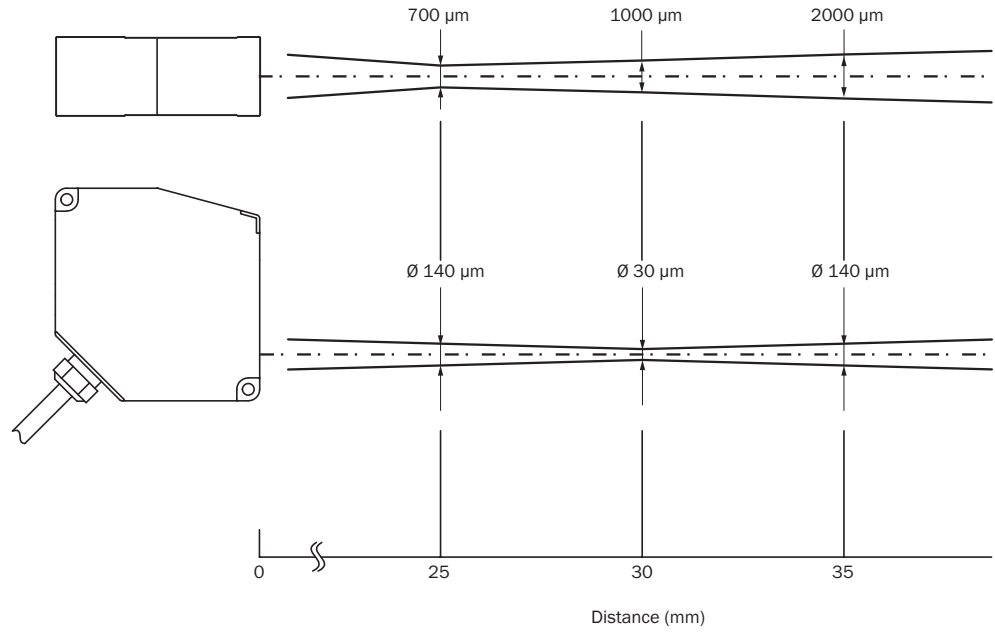


Figure 10: Typical light spot size of OD5000-C30W05

OD5000-C85T20

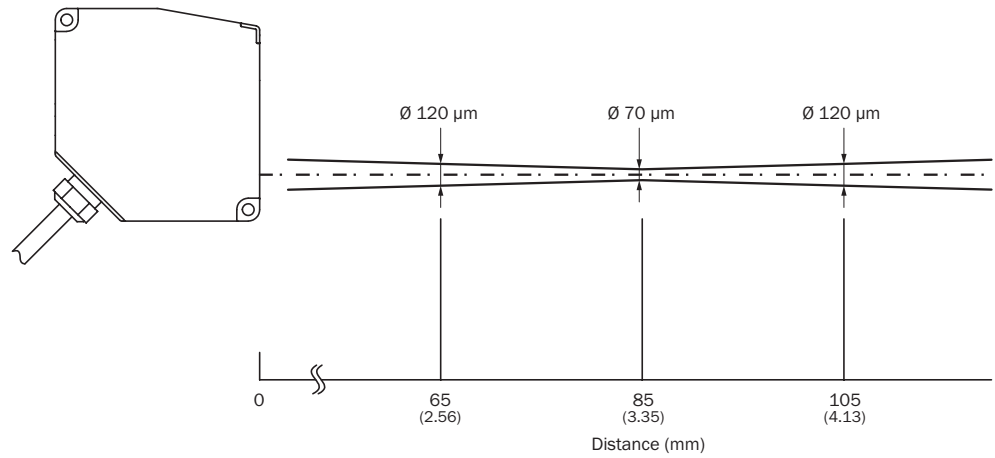


Figure 11: Typical light spot size of OD5000-C85T20

OD5000-C85W20

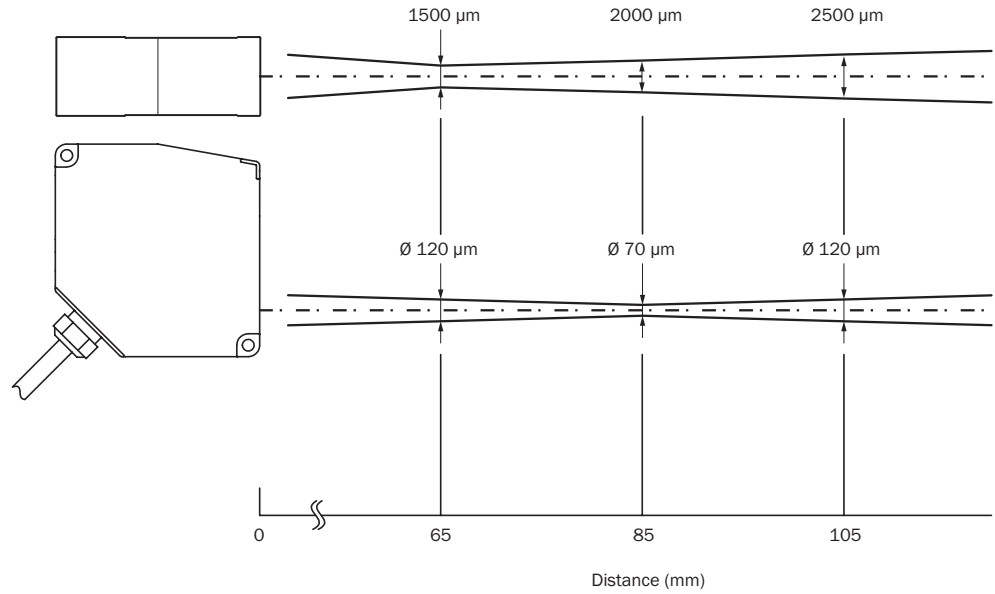


Figure 12: Typical light spot size of OD5000-C85W20

OD5000-C150T40

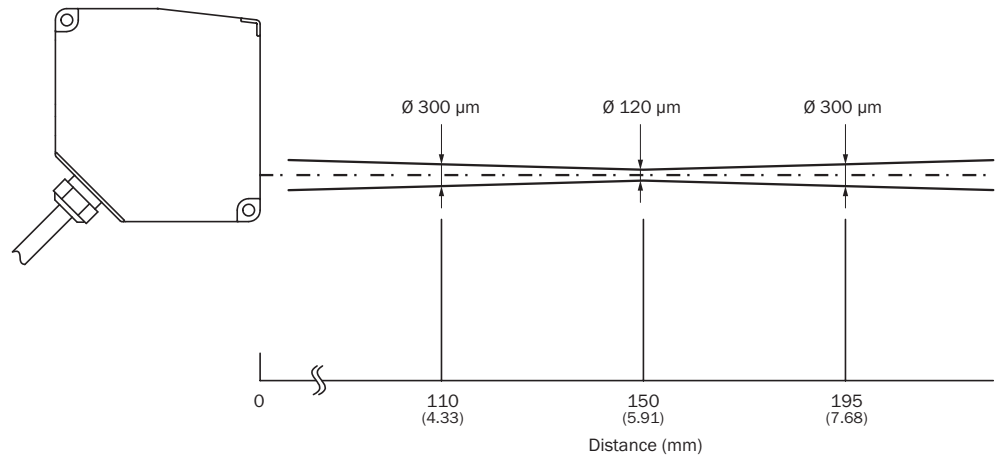


Figure 13: Typical light spot size of OD5000-C150T40

OD5000-C150W40

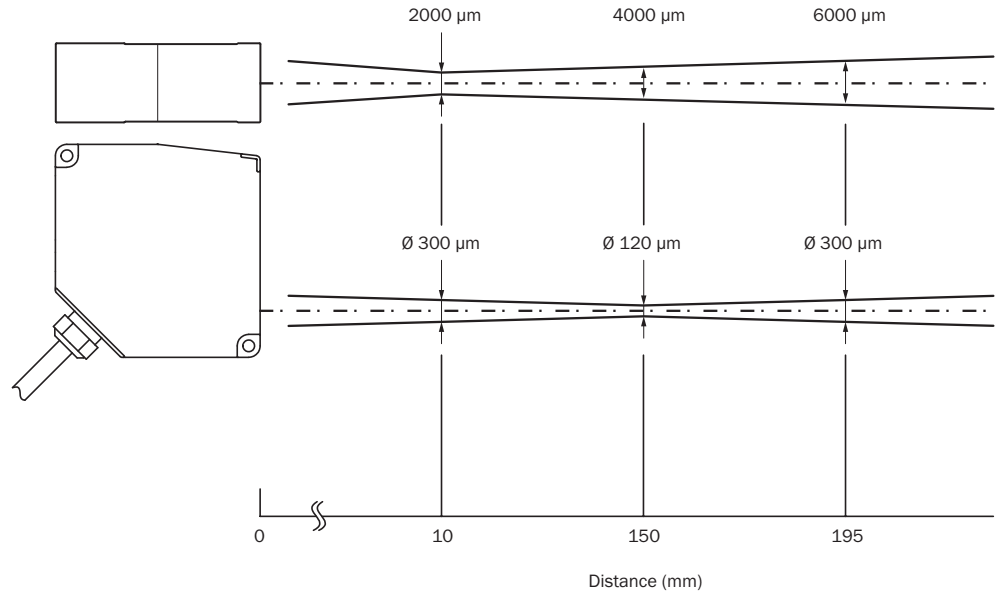


Figure 14: Typical light spot size of OD5000-C150W40

3.3 Product identification

Type label

The following information can be read from the type label on the device:



Figure 15: OD5000 type label

- ① Type codes
- ② Part number
- ③ Serial number
- ④ MAC address
- ⑤ Version number

- ⑥ EEUP information for China
- ⑦ RCM mark of compliance
- ⑧ Place of manufacture
- ⑨ EU conformity mark
- ⑩ Bar code
- ⑪ US and Canada conformity marks

4 Transport and storage

4.1 Transport

For your own safety, please read and observe the following notes:



NOTICE

Damage to the product due to improper transport.

- The device must be packaged for transport with protection against shock and damp.
- Recommendation: Use the original packaging as it provides the best protection.
- Transport should be performed by trained specialist staff only.
- The utmost care and attention is required at all times during unloading and transportation on company premises.
- Note the symbols on the packaging.
- Do not remove packaging until immediately before you start mounting.

4.2 Unpacking

- Before unpacking, it may be necessary to equalize the temperature to protect the device from condensation.
- Handle the device with care and protect it from mechanical damage.

4.3 Transport inspection

Immediately upon receipt in Goods-in, check the delivery for completeness and for any damage that may have occurred in transit. In the case of transit damage that is visible externally, proceed as follows:

- Do not accept the delivery or only do so conditionally.
- Note the scope of damage on the transport documents or on the transport company's delivery note.
- File a complaint.



NOTE

Complaints regarding defects should be filed as soon as these are detected. Damage claims are only valid before the applicable complaint deadlines.

4.4 Storage

Store the device under the following conditions:

- Recommendation: Use the original packaging.
- Do not store outdoors.
- Store in a dry area that is protected from dust.
- So that any residual damp can evaporate, do not package in airtight containers.
- Do not expose to any aggressive substances.
- Protect from sunlight.
- Avoid mechanical shocks.
- Storage temperature: [see "Technical data", page 81](#).
- Relative humidity: [see "Technical data", page 81](#).
- For storage periods of longer than 3 months, check the general condition of all components and packaging on a regular basis.

5 Mounting

5.1 Scope of delivery

Included with delivery

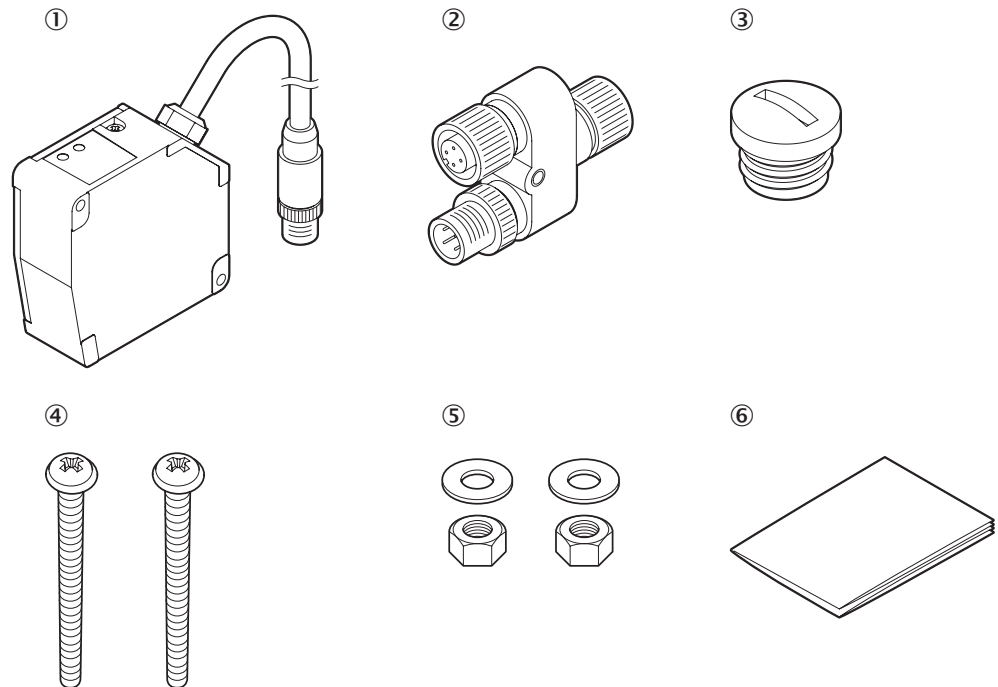


Figure 16: Scope of delivery

- ① OD5000
- ② Y-distribution (included with delivery)
- ③ Protective cap for Y-distribution
- ④ 2 x screws, each M4 x 50 mm
- ⑤ 2 x M4 nuts and 2 x washers
- ⑥ Safety notes

Optional: Accessories

Supplied documentation:

- Safety notes



NOTE

All available documentation can be found online at:

- ▶ www.sick.com/OD5000

5.2 Facilities for connecting

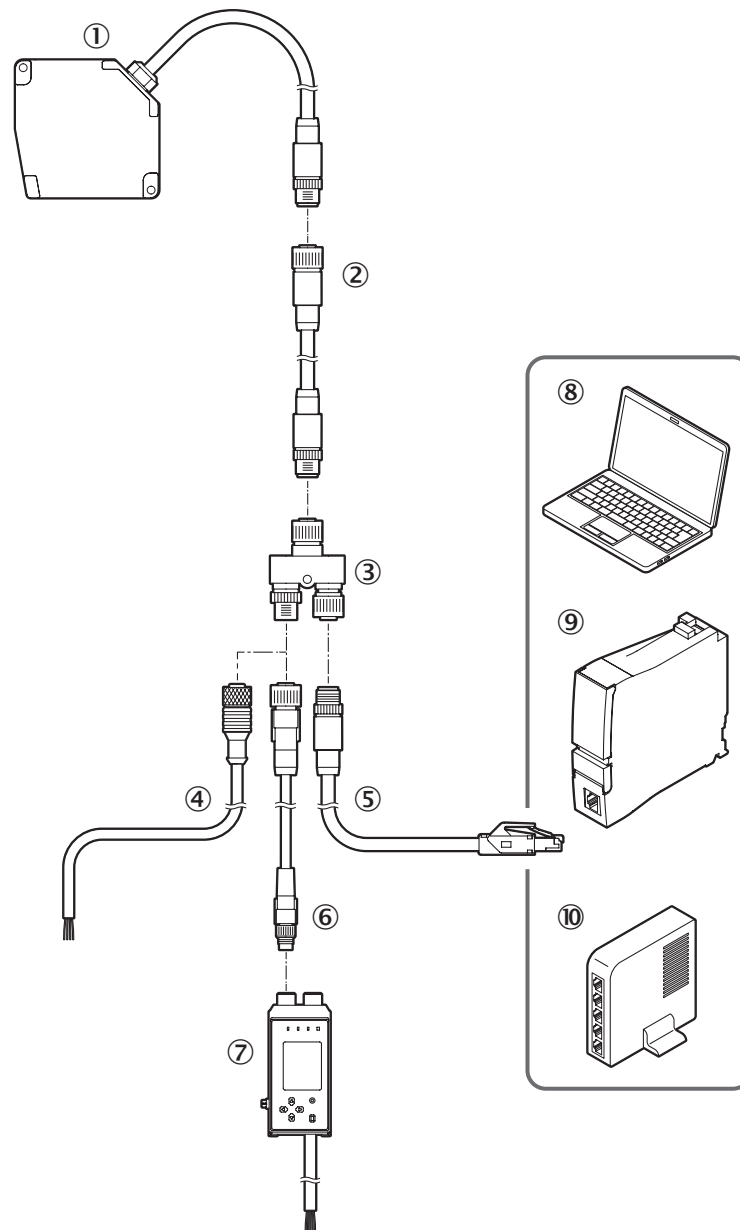


Figure 17: Facilities for connecting

- ① OD5000
- ② Sensor head extension cable (e.g., DSC-1208-G02MA, part number 6064004) ¹⁾
- ③ Y-distribution (included with delivery)
- ④ Cable with open ends (e.g., YF2A14-020UB3XLEAX, part number 2095607)
- ⑤ Ethernet cable (e.g., SSL-2J04-G02ME, part number 6034414)
- ⑥ M12 AOD1 connection cable, 4-pin on M8, 4-pin (e.g., DSL-2804-G02MC, part number 6039180)
- ⑦ AOD1
- ⑧ PC
- ⑨ PLC
- ⑩ Switch

¹⁾ We do not recommend using a standard cable. This connection cable is designed as a twisted pair.

5.3 Mounting instructions

- Observe the technical data.
- Protect the sensor from direct sunlight.
- To prevent condensation, avoid exposing the sensor to rapid changes in temperature.
- The mounting site has to be designed for the weight of the device.
- To avoid inaccurate measurements when installing multiple devices: Make sure that the laser light spot of one device is not in the visible range of another device.
- Take into account the device warm-up time of 10 minutes. During the device warm-up phase, the measured values are subject to an increased variance (temperature drift).

5.4 Mounting device

1. Mount the displacement measurement sensor using the designated fixing holes, see ["Setup and dimensions", page 11](#).
2. Make the electrical connection. Attach and tighten a voltage-free cable, see ["Connecting the device electrically", page 30](#).
3. Switch on the supply voltage.
- ✓ The status LED lights up green.
The device needs around 10 seconds of initialization time before it is ready for operation.
4. Align the light spot so that the desired object is measured.

Mounting on the wall

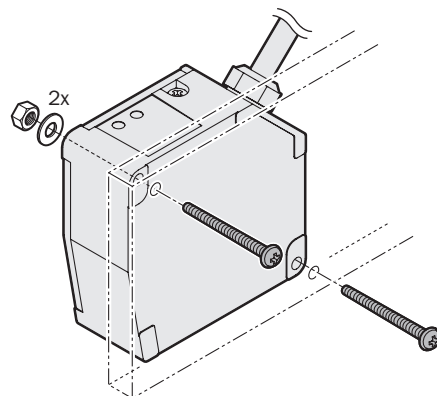


Figure 18: Mounting on the wall

Permissible bend radii of the connection cable

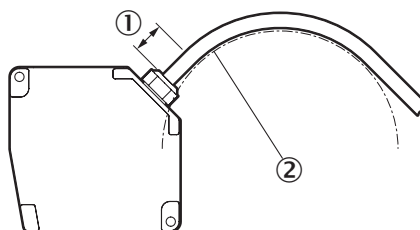


Figure 19: Permissible bend radius

- ① At least 10 mm
- ② Radius of at least 60 mm



NOTICE

- Do not bend the cable less than 10 mm from the sensor head.
- Do not bend the cable with a radius of more than 60 mm.

Mounting variations

There are two mounting variations for the device. Typically, diffuse reflection is used. Specular reflection is used when transparent or reflective surfaces are to be registered.



NOTE

The housing form for the device indicates the orientation of the correct mounting method. When mounting the device for the measurement of reflective objects, the device must be mounted so that it is slightly tilted. In doing so, the slanted edge of the housing must be positioned so that it is perpendicular to the measuring object. In this mounting variation, only a reduced measuring range is available, see "Technical data", page 81.

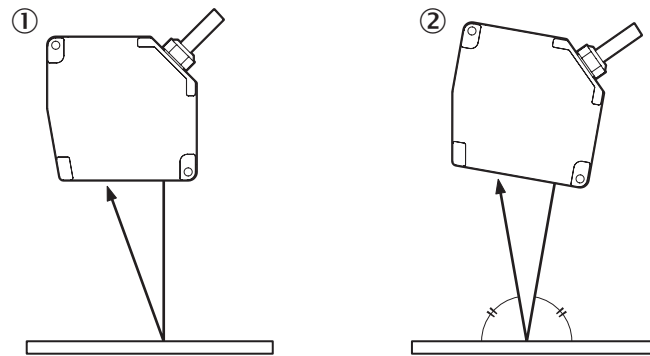


Figure 20: Mounting variations

- ① Diffuse reflection
- ② Specular reflection (except OD5000-C15(T/W)05)

5.4.1 Mounting the device depending on application

With height differences

The preferred direction must be taken into account during mounting in order to prevent shadows.

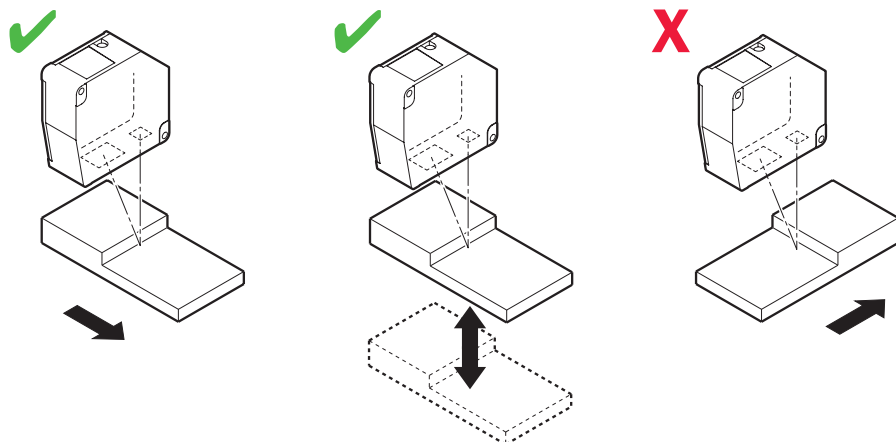


Figure 21: Mounting with height differences

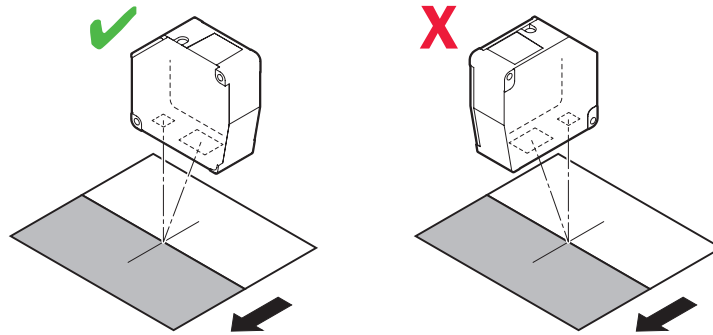
With different material or colors

Figure 22: Mounting with different material or colors

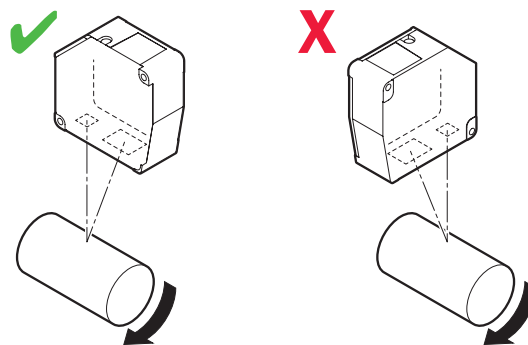
With rotating surfaces

Figure 23: Mounting with rotating surfaces

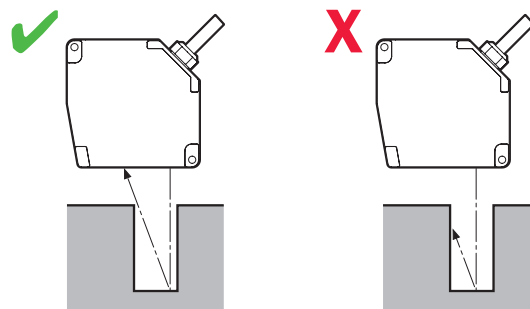
With holes or recesses

Figure 24: Mounting with holes or recesses

Mounting on the wall

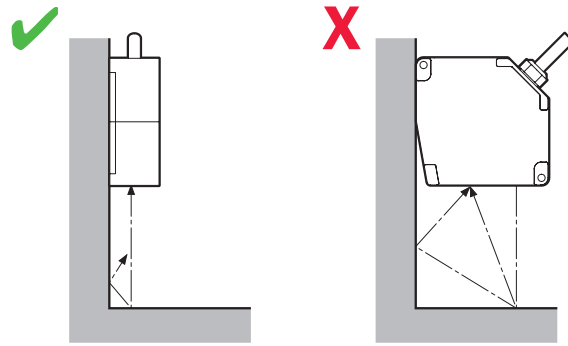


Figure 25: Mounting on the wall

6 Electrical installation

6.1 Safety



WARNING

Personal injury due to incorrect supply voltage.

An incorrect supply voltage may result in personal injury.

- Only operate the device using safety extra-low voltage and safe electrical insulation as per protection class III.



NOTICE

Equipment damage or unpredictable operation due to working with live parts.

Working with live parts may result in unpredictable operation.

- Only carry out wiring work when the power is off.
- Only connect and disconnect electrical connections when the power is off.

6.2 Wiring notes



NOTICE

Faults due to incorrect wiring.

Incorrect wiring may result in operational faults.

- Follow the wiring notes precisely.



NOTE

Preassembled cables can be found online at:

- www.sick.com/OD5000

6.3 Pin assignment of the connections

Y-distribution

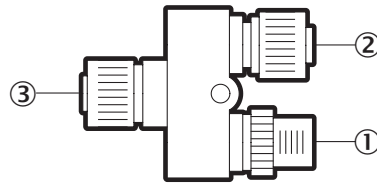


Figure 26: Y-distribution connections

- ① M12, 4-pin, A-coded
- ② M12, 5-pin, D-coded
- ③ M12, 8-pin, A-coded

The Y-distribution is only intended for use as a distributor and not as an amplifier.

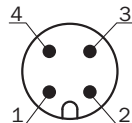


Figure 27: Male connector, M12, 4-pin, A-coded

Connection ① to the Y-distribution

Table 2: Pin assignment on 4-pin M12 male connector

Pin	Signal	Function
1	24 V	Voltage supply
2	Input (MF) / RS485+	Input MF (NPN) / Reserved
3	0 V	Voltage supply
4	Input (MF) / RS485-	Input MF (PNP) / Reserved
-	Shield	-

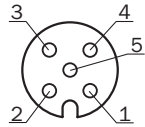


Figure 28: Female connector, M12, 5-pin, D-coded

Connection ② to the Y-distribution

Table 3: Pin assignment on 5-pin M12 female connector

Pin	Signal	Function
1	TxD+	Network interface
2	RxD+	Network interface
3	TxD-	Network interface
4	RxD-	Network interface
5	NC	Not connected
-	Shield	-

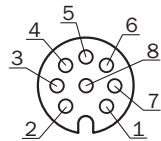


Figure 29: Female connector, M12, 8-pin, A-coded

Connection ③ to the Y-distribution

Table 4: Pin assignment on 8-pin M12 female connector

Pin	Signal	Function
1	Input (MF) / RS485+	Input MF (NPN) / Reserved
2	0 V	Voltage supply
3	24 V	Voltage supply
4	TxD-	Network interface
5	RxD+	Network interface
6	TxD+	Network interface
7	Input (MF) / RS485-	Input MF (PNP) / Reserved
8	RxD-	Network interface
-	Shield	-

Pin assignment of the connections for M12 converter, RJ45

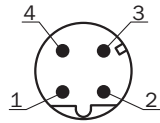


Figure 30: Male connector, M12, 4-pin, D-coded

Table 5: Pin assignment on 4-pin M12 male connector

Pin	Signal	Function
1	TxD+	Network interface
2	RxD+	Network interface
3	TxD-	Network interface
4	RxD-	Network interface
-	Shield	-

Pin assignment for M12 voltage supply, 4-pin (based on DOL-1204-G02MAC, part number 2088079, can be used for OD5000 standalone operation)

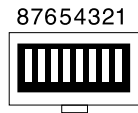


Figure 31: Male connector, RJ45

Table 6: Pin assignment on male connector, RJ45

Pin	Signal	Function
1	TxD+	Network interface
2	TxD-	Network interface
3	RxD+	Network interface
4	NC	Not connected
5	NC	Not connected
6	RxD-	Network interface
7	NC	Not connected
8	NC	Not connected
-	Shield	-

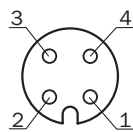


Figure 32: Male connector, M12, 4-pin, A-coded

Table 7: Pin assignment on 4-pin M12 female connector

Pin	Signal	Function
1	24 V	Voltage supply
2	Input (MF) / RS485+	Input MF (NPN) / Reserved
3	0 V	Voltage supply
4	Input (MF) / RS485-	Input MF (PNP) / Reserved
-	Shield	-

6.4 Connecting the device electrically

**NOTE**

The connection diagram, and information on inputs and outputs, can be found on the side plate on the device.

**NOTICE**

All electrical circuits must be connected to the device with safety extra-low voltage (SELV or PELV).

1. Ensure that the voltage supply is not connected.
2. Observe the wiring instructions, [see "Wiring notes", page 27](#).
3. Connect the device according to the connection diagram.

7 Operation

7.1 General notes

If the device is not able to perform a measurement even though the measuring object is within the specified measuring range, the alignment should be checked and optimized if necessary see "[Mounting the device depending on application](#)", page 24. In general, adjusting the measuring rate can increase the measuring ability for very dark objects, for example.

To prevent EMC interference, please observe the wiring instructions.

7.2 Control elements and status indicators

7.2.1 Indicator lights

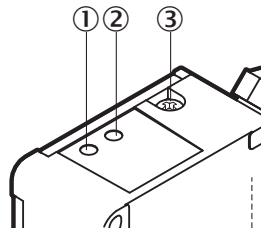


Figure 33: OD5000 control panel

- ① Communication LED (link)
- ② Status LED (power)
- ③ Cover screw for reset pushbutton

Table 8: Meaning of the indicator lights

Indicator	Status	Color	State
Communication LED (link)	● (flashing)	Green	Ethernet communication is active
Status LED (power)	● (flashing)	Blue	Laser off
	● (flashing)	Red	Invalid measurement
	● (permanent)	Orange	Measured value valid, output state for channel A = high
	● (permanent)	Green	Measured value valid, output state for channel A = low
	● (flashing)	White	"Find me" is active

- (flashing) Flashing
- (permanent) Permanently on

7.2.2 Operating elements

Table 9: Functions of the reset pushbutton

Hold down pushbutton for	Function	LED status	Description
< 1 s	None	Unchanged	Changes are not adopted if pushbutton is not pressed for long enough
1 to 5 s	IP address is initialized (static IP)	Flashing orange (slowly)	IP address is changed to 192.168.0.01
5 to 10 s	IP address is changed (DHCP)	Flashing green (slowly)	IP address is obtained and set to DHCP
> 10 sec	All settings are initialized	Flashing green (quickly)	All settings are reset to the factory settings



NOTE

- Press reset pushbutton to reset all settings to factory settings.

The reset pushbutton is only accessible once the screw has been removed.

- Always remove and store the screw together with the sealing ring.
- Refit the screw and sealing ring.
- Observe the maximum torque of 0.08 Nm ±20%.

The IP67 enclosure rating is only ensured with a proper screw connection and intact sealing ring.

The SOPASair web browser should be used to configure the sensor. The UDP/IP interface is mainly recommended for streaming the measured values.

7.3 Operation via web browser (SOPASair)

7.3.1 Determining the device IP address

DHCP is preset on the device as standard meaning that the IP address is obtained automatically.

In order to ascertain the IP address assigned to the device, please contact the relevant network administrator or use SOPAS ET.

The device IP address can also be verified and adjusted by a device-specific search in SOPAS ET.

The most up-to-date version of the software is available at:

- ▶ www.sick.com/OD5000

7.3.2 Connecting via the web browser

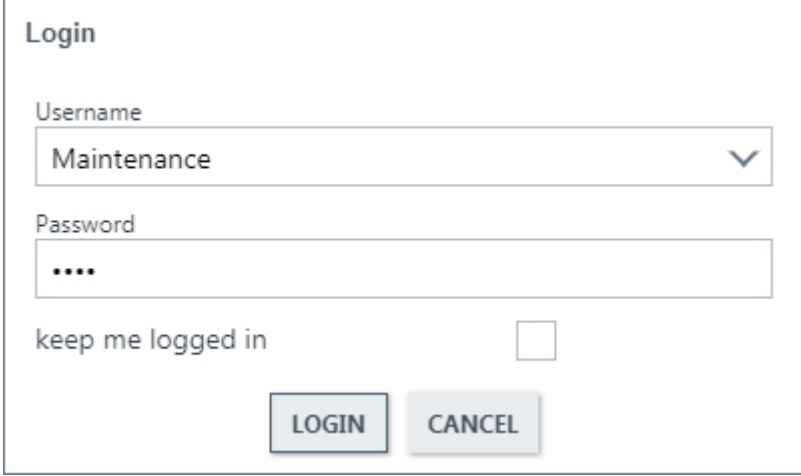
The following browsers are supported:

- Internet Explorer (version 11 or higher)
- Google Chrome (version 49 or higher)

1. Start browser.
2. Enter the device IP address.
- ✓ The SOPASair settings screen is displayed.

Logging in

The user must log in to edit the sensor settings. The button is located at the bottom left in the settings screen (person icon).



The screenshot shows a login form titled "Login". It contains two input fields: "Username" with the value "Maintenance" and a dropdown arrow, and "Password" with masked characters "....". Below the password field is a checkbox labeled "keep me logged in". At the bottom of the form are two buttons: "LOGIN" and "CANCEL".

Figure 34: Log-in screen

The **Maintenance** user level is available for choosing settings.

User: Maintenance

Password: main

The **Service** and **SICK Service** user level is for the exclusive use of trained and authorized service personnel at SICK AG, see ["Expert"](#), page 61.



NOTE

After logging in, it might be necessary to click on the "Pencil" button (top right in the window) to enable editing.

We recommend activating the "Stay logged in" selection box so you do not have to log in again every time the page is updated.

7.3.3 Overview of SOPASair

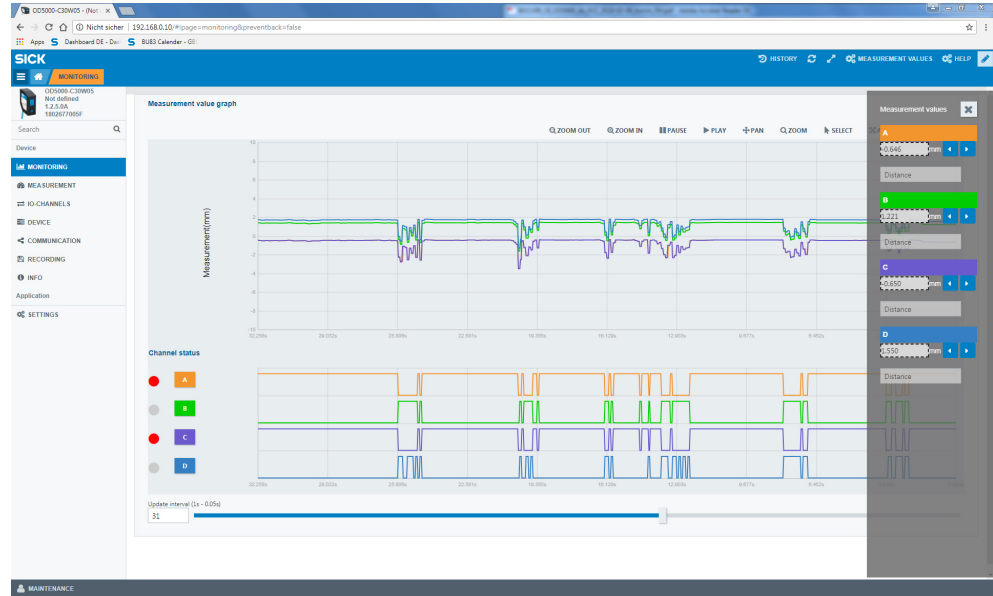


Figure 35: Overview of SOPASair

The following menu items are available when viewed online:

- Monitoring
- Measurement
- I/O channels
- Device
- Communication
- Recording
- Info
- Expert

The left-hand navigation screen can be viewed as standard but can be hidden by clicking on the upper right-hand buttons with three bars.

Three buttons can be seen on each bar at the top:

Measured values: Displays the current measured values. The display of the measured value (number of decimal places) can be adapted using two buttons.

Help: Displays help texts on the current settings.

First setup wizard: Provides a guided, step-by-step sensor configuration and is recommended for initial commissioning.

7.3.4 Monitoring



Figure 36: Overview of the Monitoring tab

The measured value plotter displays the current measured values (distance/thickness). Current measured values can be hidden or displayed at any time using the **Measured values** button in the bar at the top of the screen. The color corresponds to the respective channel.

The display of the individual channels can be activated and deactivated using buttons **A** to **D**.

The digital plotter displays the statuses of the output signals for channels A to D.

The status of the outputs is displayed by LEDs to the left of the buttons:

- Red = output active
- Grey = output inactive

Speed: -  +

The speed at which the measured values and the digital plotter are output is adjusted equally by sliding the controller on the speed bar.

7.3.5 Measurement

Measurement settings can be made in the **Measurement** tab.

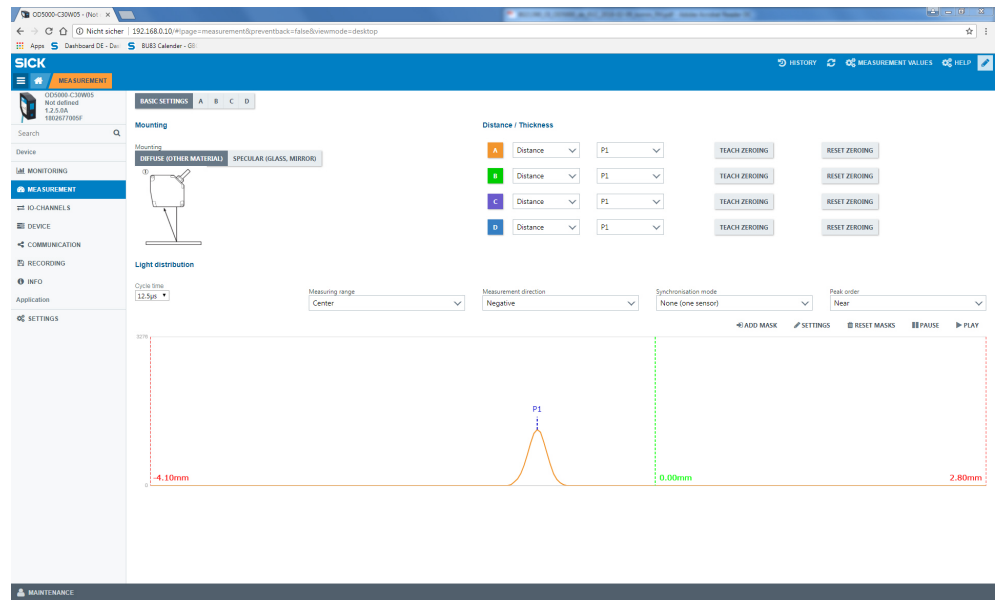


Figure 37: Overview of the Measurement tab

7.3.5.1 Setting diffuse or specular reflection

One of two options can be selected depending on the measuring object and the mounting method, see "Mounting device", page 23.



NOTE

Some device variants only support one mode.

The OD5000-C150xxx only supports diffuse reflection, the OD5000-C015xxx only specular reflection.

Part number	Device	Diffuse	Specular
6063619	OD5000-C15T01	Not supported	x
6063620	OD5000-C15W01	Not supported	x
6063621	OD5000-C30T05	x	x
6063622	OD5000-C30W05	x	x
6063623	OD5000-C85T20	x	x
6063624	OD5000-C85W20	x	x
6063625	OD5000-C150T40	x	Not supported
6063626	OD5000-C150TW0	x	Not supported



NOTE

The measuring range is reduced if the OD5000-C30xxx or OD5000-C85xxx is reflected specularly, see "Technical data", page 81.

7.3.5.2 Determining the measurement type

This function determines which measurement is used via the respective channel.

Table 10: Adjustments for the measurement type

Setting	Meaning
Distance	Measures the distance between the zero point and a defined peak (object surface)

Setting	Meaning
Thickness measurement > x mm	Measures the distance between two peaks, e.g., a transparent object with several reflective surfaces (e.g., layers of glass). When selecting, consider which thickness is to be measured.
Thickness measurement < x mm	

Table 11: Minimum thickness of transparent material (thickness measurement)

Type	OD5000-C15xxx	OD5000-C30xxx	OD5000-C85xxx	OD5000-C150xxx
Standard thickness measurement	≥ 0.18 mm	≥ 0.6 mm	≥ 2.0 mm	Not supported
Thin layer thickness measurement ¹	≥ 0.06 mm	≥ 0.18 mm	≥ 0.5 mm	Not supported

¹ The linearity error increases by a factor of 5 ... 10.

Depending on the selected measurement type, it is possible to determine on which peak or between which peaks the measurement is to be taken.

With the distance measurement type, up to eight peaks can be selected. Peak 1 (P1) is activated by default.

With the thickness measurement type (for measuring a transparent object), a selection must also be made of the peaks between which the measurement is to be taken. If the selected peak does not exist then a measurement is not taken. If the same peak is selected twice in this case, 0 is output as the measured value.



NOTE

The thickness may only be measured with **specular reflection** mounting. This mode is not available for all devices in the OD5000 series, see "[Setting diffuse or specular reflection](#)", page 36.

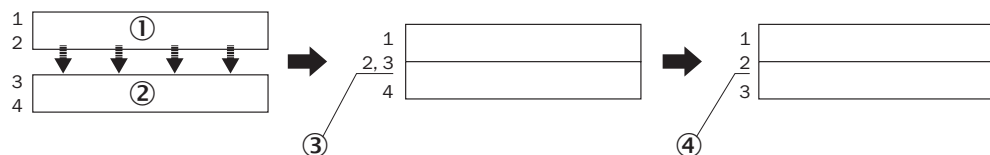


Figure 38: Thickness measurement of reflective surfaces

- ① First glass pane
- ② Second glass pane
- ③ Transparent objects very close to one another
- ④ Incorrectly detected single peak



NOTE

If two overlapping glass panes are measured so that the rear side of one pane is very close to the front side of the other pane, the sensor cannot differentiate between the two surfaces. The sensor then detects both surfaces as a single reflective surface.

Monitor the light wave shape to check how well the sensor detects reflective surfaces (see "[Checking the light distribution curve and peaks](#)", page 40).

7.3.5.3 Teaching in the zero point

The current distance is taught in as a new zero point (reference point) or reset to the output value.

7.3.5.4 Setting the sampling duration

The following settings are possible:

- 12.5 μ s
- 25 μ s
- 50 μ s (default value)
- 100 μ s
- 500 μ s
- 1,000 μ s
- AUTO (selects the sampling rate for the quickest possible measurement depending on the measuring object)



NOTE

If the sampling duration is set to the shortest time of 12.5 μ s then the measuring range is reduced.

- Select the required range (near, medium, far) via the configuration interface.

For a sampling duration of 12.5 μ s

Table 12: Measuring range at sampling time 12.5 μ s (OD5000-C15xxx and OD5000-C30xxx)

	OD5000-C15W01	OD5000-C15T01	OD5000-C30W05	OD5000-C30T05
Near	14.0 mm to 14.6 mm		25.0 mm to 28.1 mm 22.5 mm to 24.0 mm (for specular reflection)	
Medium (starting value)	14.4 mm to 15.4 mm		27.8 mm to 31.9 mm 22.8 mm to 27.9 mm (for specular reflection)	
Dist.	15.3 mm to 16.0 mm		31.1 mm to 35.0 mm 26.7 mm to 28.5 mm (for specular reflection)	

Table 13: Measuring range at sampling time 12.5 μ s (OD5000-C85xxx and OD5000-C150xxx)

	OD5000-C85W20	OD5000-C85T20	OD5000-C150W40	OD5000-C150T40
Near	65.0 mm to 77.7 mm 71.5 mm to 74.3 mm (for specular reflection)		110.0 mm to 134.4 mm	
Medium (starting value)	73.5 mm to 90.8 mm 70.6 mm to 86.9 mm (for specular reflection)		124.8 mm to 166.3 mm	
Dist.	84.8 mm to 105.0 mm 81.0 mm to 91.5 mm (for specular reflection)		150.2 mm to 190.0 mm	

An upper and lower limit must be set for the auto setting. The actual sampling duration is automatically adjusted within these limits.

Table 14: Adjustments for the upper and lower limit

Lower limit	Upper limit
25 μ s (default value)	25 μ s
50 μ s	50 μ s
100 μ s	100 μ s
200 μ s	200 μ s

Lower limit	Upper limit
500 μs	500 μs (default value)
1,000 μs	1,000 μs

7.3.5.5 Synchronizing several OD5000 sensors

If several sensor heads are used in the application, they may be synchronized using the following settings. **One sensor head** is selected by default. To use two sensor heads, a drop-down menu is displayed with the following request:

Table 15: Adjustments for synchronization mode

Setting	Meaning
Synchronous	Synchronizes several sensor heads
Anti interference 1/2	Switches between two sensor heads

The following should be considered when using these modes:

In synchronization mode, the measurement results from two sensor heads are recorded simultaneously. An application possibility is measuring the thickness of non-transparent objects using two sensor heads, for example. The individual results from the sensor heads must be accounted for using special control software, which is not possible with the SOPASair configuration software.

In **Anti interference** mode, the measurement results from several sensor heads are recorded one after the other. This increases the measurement time to double the sampling duration for that measurement. This can be in used, for example, in an application in which the laser beams overlap a pair of sensor heads.

To use this mode, the following settings must be made:

1. Define one device as a master and the others as slaves, see "[Network settings](#)", page 57.
 2. Set **Anti interference 1** for the master.
 3. Set **Anti interference 2** for the slave.
- ✓ The devices will now take measurements one after the other.

7.3.5.6 Determining the direction of detection

The direction of detection determines whether the measured value increases (positive) or decreases (negative) when the distance between the device and measuring object increases.

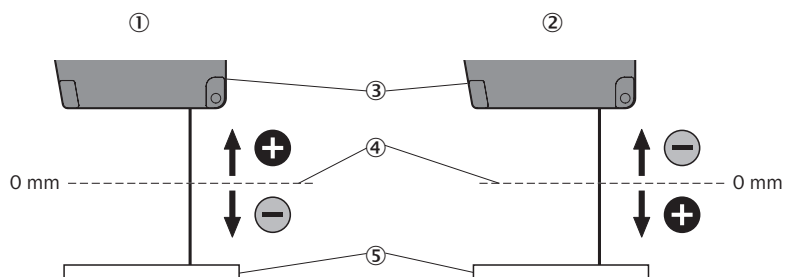


Figure 39: Direction of detection

- ① Set to positive
- ② Set to negative
- ③ Sensor
- ④ Center point of the measurement
- ⑤ Measuring object

To determine the order of the peaks, see "Checking the light distribution curve and peaks", page 40.

7.3.5.7 Checking the light distribution curve and peaks

In this settings display, the user can check the light waveform which is displayed on the receiver. The peak displays the distance to the measuring object. If the device detects peaks then these are displayed in the corresponding light waveform and labeled P1 to P8.

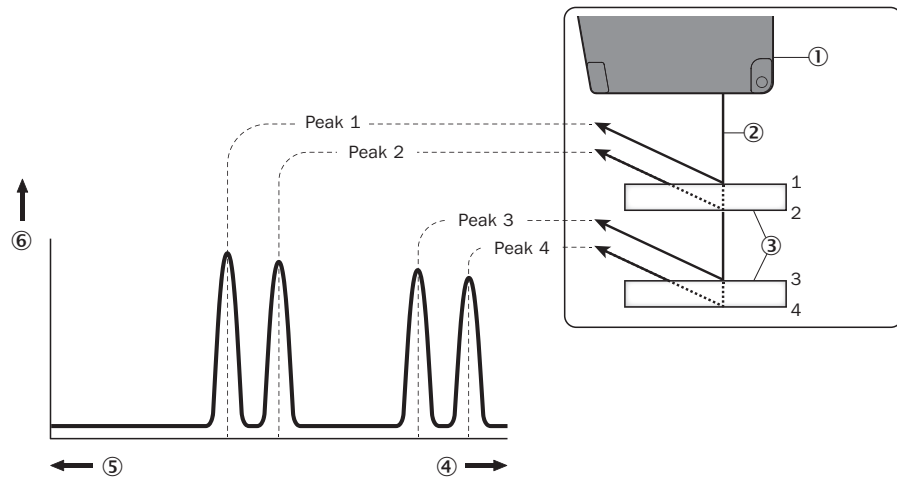


Figure 40: Light distribution curve

- ① Sensor
- ② Laser
- ③ Reflective surface
- ④ Side close to the sensor head (depending on the **Measuring direction** setting)
- ⑤ Side far from the sensor head (depending on the **Measuring direction** setting)
- ⑥ Reflected light intensity

During the measurement, light can be reflected from several surfaces at the same time; for example, from the front and rear of a transparent measuring object.

Direction of detection: The device assigns numbers to the scanned surfaces. This means that the measurement can focus on individual reflection points (peaks). The numbers are assigned (using the direction of detection: near/far) in such a way that they either increase (near) or decrease (far) beginning on the side closest to the sensor.

Example based on four glass panes:

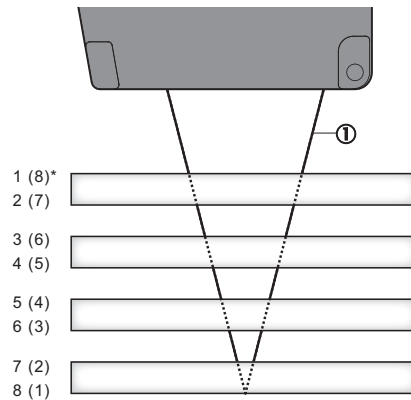


Figure 41: Peak detection

① Laser

1 = Near
 (8) = Far

Near is selected as the standard setting, i.e., the numbering increases from the side closest to the sensor.

Mask function

The **Mask** function can be used to define one or several areas in which the device does not make measurements. A typical application is the blanking of a transparent protective screen located between the measuring object and device.

7.3.6 Settings for channels A–D

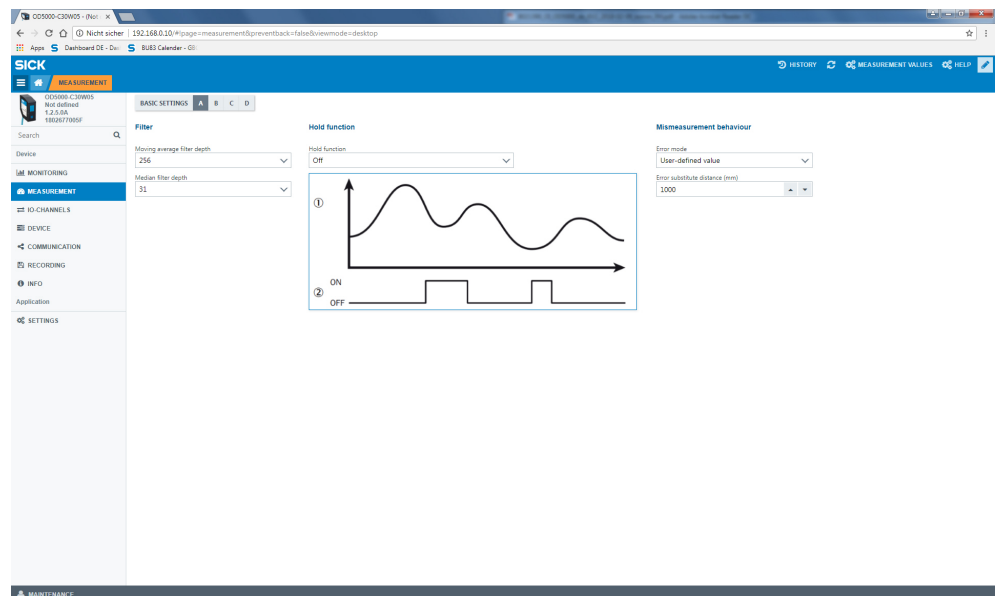


Figure 42: Overview of the settings tab for channels A–D

7.3.6.1 Setting the measurement value filter

The measurement value filters optimize the signal diagram in order to simplify the evaluation by the control system (e.g., for regulation tasks). You can select from the following filters:

- Average filter
- Median filter

By default, the average filter is set to a filter depth of 256 measured values and the median filter to a filter depth of 31 measured values.

Average filter

The average filter carries out a moving averaging of the measured values. This filter is suitable for smoothing a noisy signal diagram in order to ensure better repeatability.

Filter depth: 1 / 2 / 4 / 8 / 16 / 32 / 64 / 128 / 256 (default value) / 512 / 1024 / 2048 / 4096 / 8192 / 16384 / 32768 / 65536 (unit: measuring point)

The average filter can be deactivated by selecting filter depth 1.

Median filter

The moving median filter sorts the measured values according to their size and selects the middle value from a sequence. This filter is suitable for excluding individual outliers from the calculation of an average value.

Filter depth: Off / 7 / 15 / 31 (default value)

Both types of filter affect the response time of the device.

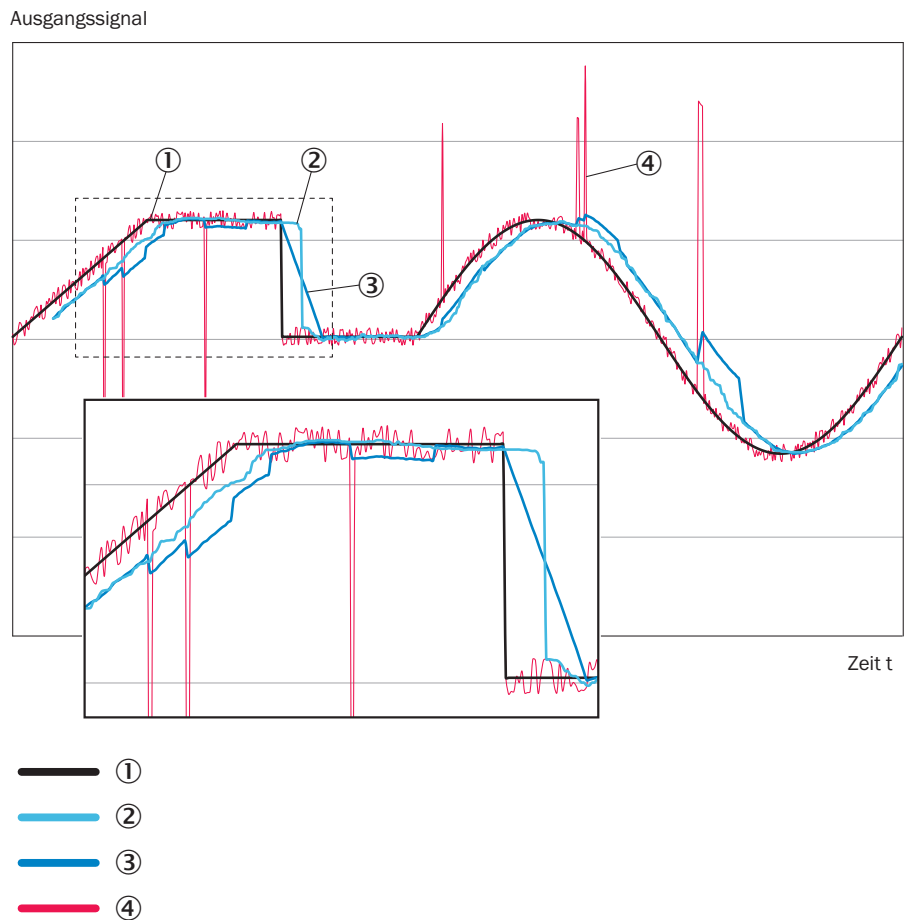


Figure 43: Median and average filter

- ① True distance
- ② Measured value with median
- ③ Measured value with averaging
- ④ Measured value without averaging

7.3.6.2 Setting the Hold function

The Hold function extracts a specific value such as the maximum or minimum value within a detection period. The value which was set under **Hold Set** is used as the holding period.

- Use this function after entering Hold Reset if Auto Peak or Auto Bottom is used.

Off

When the hold function is deactivated, the measurement result is output in an unedited format and the Hold Input is ignored.

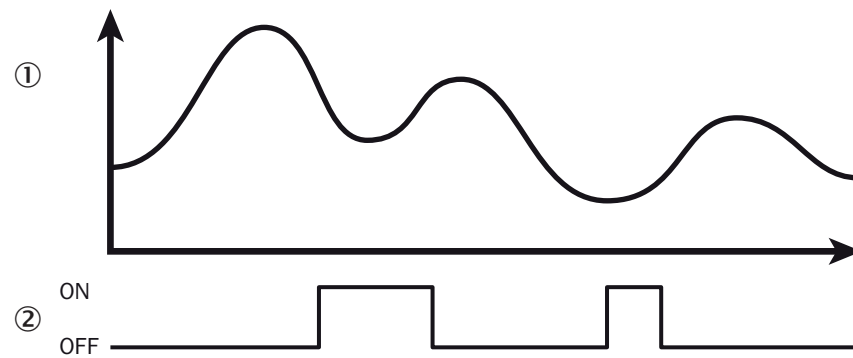


Figure 44: Hold function off

- ① Measured value
- ② Hold function

Normal

The measured value is held as long as a hold reset input is detected.

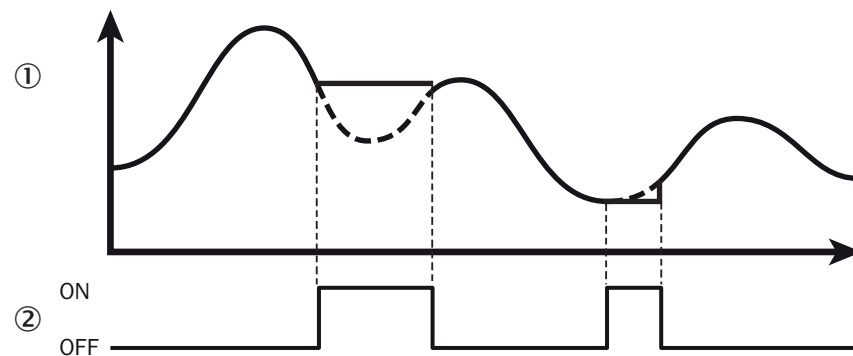


Figure 45: Normal hold function

- ① Measured value
- ② Hold function

Peak

The highest value within the detection period is output.

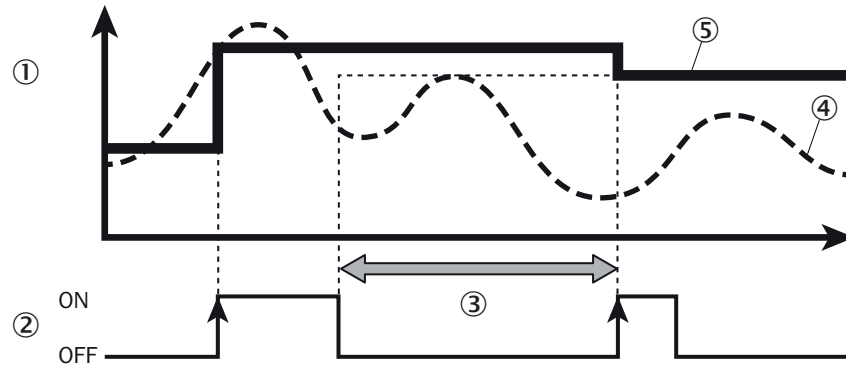


Figure 46: Hold function peak

- ① Measured value
- ② Hold
- ③ Detection period
- ④ Internal measured value
- ⑤ Measured value for the hold function peak

Bottom

The lowest value within the detection period is output.

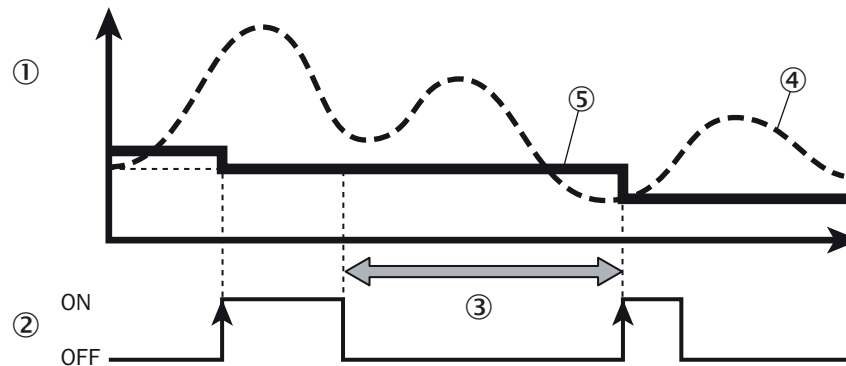


Figure 47: Bottom hold function

- ① Measured value
- ② Hold function
- ③ Detection period
- ④ Internal measured value
- ⑤ Measured value of the Bottom hold function

Sample Hold

The value for the rising signal edge is output.

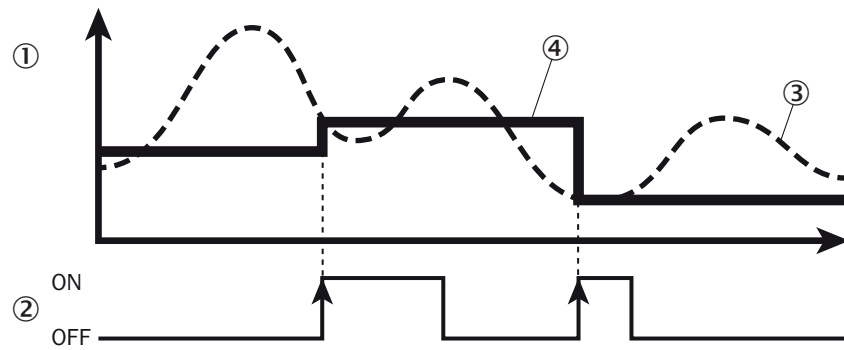


Figure 48: Sample Hold hold function

- ① Measured value
- ② Hold function
- ③ Internal measured value
- ④ Measured value of the Sample Hold hold function

Auto Peak

The highest value is recorded as soon as a hold reset input is detected.

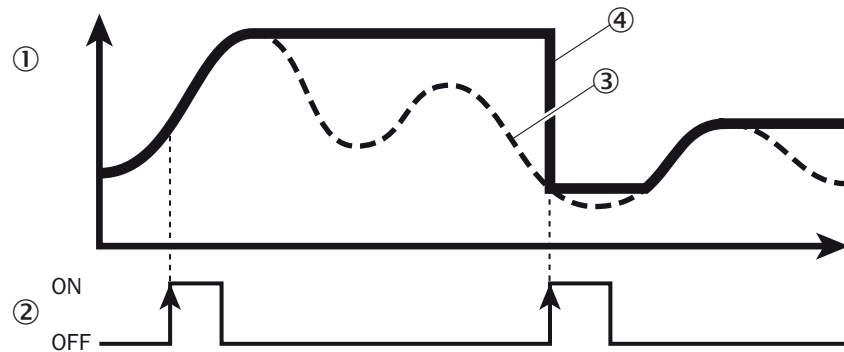


Figure 49: Auto Peak hold function

- ① Measured value
- ② Hold function
- ③ Internal measured value
- ④ Measured value of the Auto Peak hold function

Auto Bottom

The lowest value is recorded as soon as a hold reset input is detected.

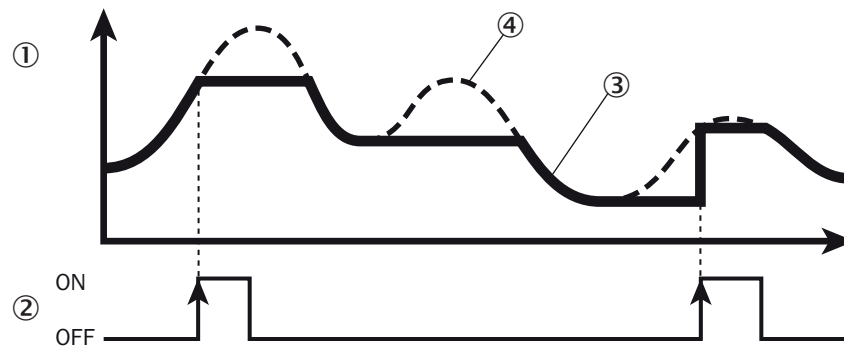


Figure 50: Auto Bottom hold function

- ① Measured value
- ② Hold function

- ③ Measured value of the Auto Bottom hold function
- ④ Internal measured value

Peak to Peak

The value is maintained from peak to peak. The differential value between the maximum (P(1)) and the minimum (B(1)) measured value within the measurement period is output.

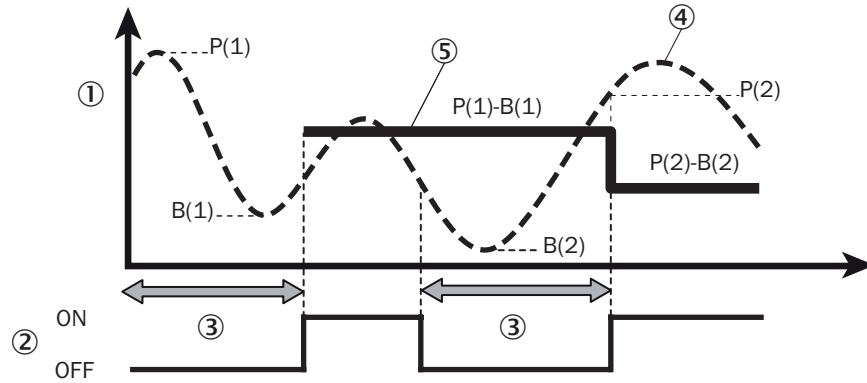


Figure 51: Peak to Peak hold function

- ① Measured value
- ② Hold function
- ③ Duration of measurement
- ④ Internal measured value
- ⑤ Output hold value

7.3.6.3 Mismeasurement behavior

This function allows you to determine the output when a measurement is not possible.

Table 16: Settings for behavior in case of mismeasurement

Setting	Meaning
User-defined value	A defined value is displayed.
Hold last value	The most recently measured value is displayed.
User-defined value at a set time	Forces the output of a user-defined value at a set time during a mismeasurement.

Mismeasurement behavior: User-defined value

The user-defined value is set in the section on **Mismeasurement behavior**.

Values of $\pm 2,147,483$ mm are possible; the default value is 1.00 mm.



NOTICE

If the **A0D1** setting is selected for **Input terminal** under **Communication**, the user-defined value is automatically adjusted to the following value:

209.7152 mm

This value must not be modified.

Error suppression time

When **User-defined value at a set time** is selected, then the number of measuring points is determined under **Error suppression time**, during which the most recently measured value is displayed. If a measurement still cannot be taken after this period then the user-defined value is displayed.

Values are possible from 0 (default value) to 4,095.

Restoration period following an error

When **User-defined value at a set time** is selected, then the number of measuring points is determined under **Restoration period following an error**. The user-defined value continues to be output although a measurement is possible again.

Values are possible from 0 (default value) to 4,095.

7.3.7 I/O channels

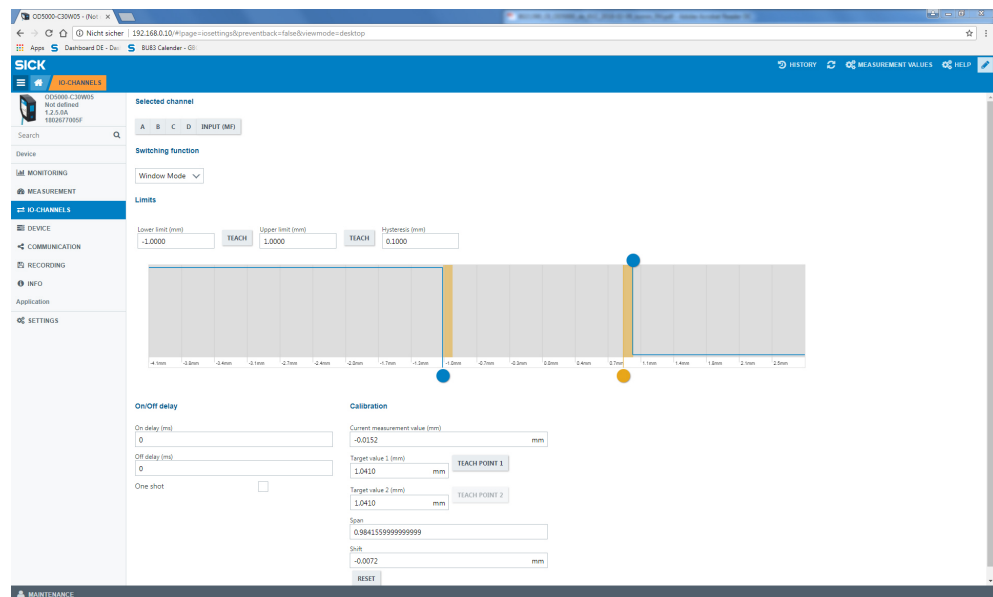


Figure 52: Overview of the I/O channels tab

In this view, the settings are made for the digital signal of each channel. Four channels are available for this. Settings can be made for each channel individually.

An MF input is also available. The settings for this option can also be made under **I/O channels**.



NOTE

The digital signals cannot be measured on the device pins but are made available via the Ethernet interface as part of data transmission.

Settings for switching modes

- Teach-in
- Manual teach-in
- Active status
- Hysteresis
- Delay mode
- Time for delay mode

The possible settings are described below.

Teach-in: A single switching point can be taught in. The switching point is set to the current distance at the time the button is pressed.

- **Q1:** A signal is output if the switching point that has been taught in is undershot. Thus the output acts as a normally open contact (“High” active status).
- **Not Q1:** A signal is output if the switching point that has been taught in is exceeded. Thus the output acts as a normally closed contact (“Low” active status).

Manual teach-in: The distance of the switching point can be set manually in 1/10 mm.

Q1 active status: The active status specifies the functionality of the switching output.

- **High:** The switching output acts as a normally open contact. A signal is output if the switching point that has been taught in is undershot.
- **Low:** The switching output acts as a normally closed contact. A signal is output if the switching point that has been taught in is exceeded.

Delay mode: Delay mode is used to output the output state change with a time delay or as a short switching pulse (1 shot).

Time for delay mode: The time for the delay mode can be set manually in ms.

7.3.7.1 Setting ObSB switching mode

ObSB = Object between Sensor and Background (object between device and background)

In this switching mode, any background can be taught in as a reference. If an object obscures the background or the distance to the background changes significantly, this causes the device to switch. This switching mode is primarily suited to the reliable detection of high-gloss or extremely dark materials. This makes it possible to detect even painted vehicle parts with large approach angles, for example.

7.3.7.2 Setting DtO switching mode

DtO = Distance to Object, single switching point

A signal is output if the measured distance value has undershot (normally open – High Active) or exceeded (normally closed – Low Active) the switching point.

If the “DtO” switching mode is selected, the required settings can be taught in or set manually.

7.3.7.3 Setting Window switching mode

An upper and a lower switching threshold are set for the switching output. A switching signal is output when the measured value is between the two switching thresholds (in the window).

7.3.7.4 Setting edge height change switching mode

The edge height change function supplies a signal at the set sensor channel as soon as there is a change in value between two measured values. A typical application for this function is counting shingles in printing applications. The sensor takes on the complex evaluation tasks carried out by the control system.

The following settings must be configured on the device in order to use the edge height change function:

Maximum and minimum height change

The maximum and minimum height change values define the smallest and largest difference in mm by which the two measured values must differ in order for there to be an edge height change. This function only takes into account the difference between two measured values and is independent of the absolute distance of the object.

Change direction

- Both: All changes in measured values within the set limits are detected.
- Positive: Only changes in measured values within the set limits which result in larger distances are detected (factory setting).
- Negative: Only changes in measured values within the set limits which result in smaller distances are detected (to factory setting).

Hysteresis

Hysteresis is the difference in distance between the switch-on and switch-off points. This is necessary to ensure a stable signal when the measured distance fluctuates around the switching point that has been set. Hysteresis can be configured freely with most distance sensors and is stated in mm. More precise logic can be achieved by setting a lower value. Choose a higher value to ensure a more stable signal and reduce the probability of a faulty switch.

Change direction

The change direction value defines whether changes in measured values which result in smaller or larger distances or in both directions are detected.

Cycle offset

The cycle offset value specifies which previous output value is compared with the value currently measured.



NOTE

A permanently set cycle time ($\geq 25 \mu\text{s}$) must be used in the edge height jump operating mode, see "Setting the sampling duration", page 38. This ensures time consistency for the output of measured values.

This switching function cannot be used in combination with the "Auto" sampling rate. In this case, the device independently changes the sampling rate from "Auto" to the standard value.

Values from 0 to 100,000 are possible (number of measurements), default value is 0.

7.3.7.5 Setting limits

The threshold is set using limits. In doing so, the digital signal is set to **ON** or **OFF**.

Table 17: Upper limit of setting options

Device	Possible values	Default value
OD5000-C15xxx	$\pm 2,000.00$ mm	+0.2 mm
OD5000-C30xxx	$\pm 2,000.00$ mm	+0.5 mm
OD5000-C85xxx	$\pm 2,000.00$ mm	+2.0 mm
OD5000-C150xxx	$\pm 2,000.00$ mm	+4.0 mm

Table 18: Lower limit of setting options

Device	Possible values	Default value
OD5000-C15xxx	$\pm 2,000.00$ mm	-0.2 mm

Device	Possible values	Default value
OD5000-C30xxx	±2,000.00 mm	-0.5 mm
OD5000-C85xxx	±2,000.00 mm	-2.0 mm
OD5000-C150xxx	±2,000.00 mm	-4.0 mm

7.3.7.6 Setting the hysteresis

If the measured value rises slightly above or drops slightly below the threshold, this can lead to the input and output repeatedly switching on and off within a short space of time. This can be prevented by assigning a defined tolerance to the measured value via the hysteresis setting, beyond which the device switches.



NOTE

The limits and the hysteresis can also be set by moving the corresponding marker in the graphic (blue: limits, yellow: hysteresis).

Values of ±2,000.000 mm are possible; the default value is 0.0000 mm.

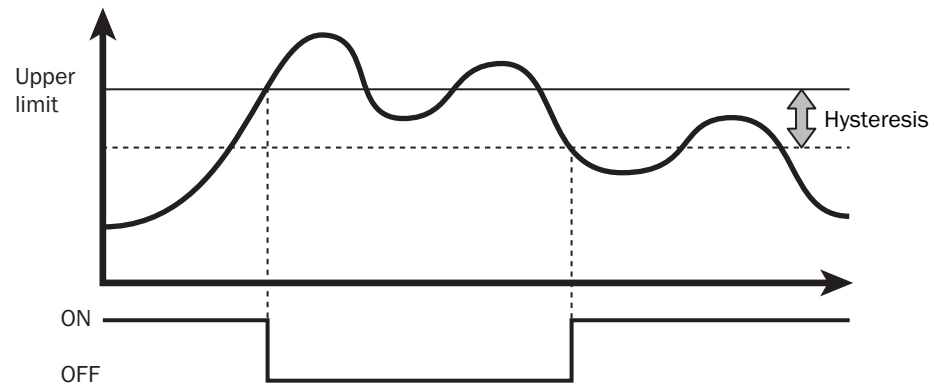


Figure 53: Hysteresis

7.3.7.7 Setting the switch-on delay (on delay)

This setting is used to delay the switching on of the output by a set amount of time if the measured value exceeds the threshold.

This setting prevents the input and output from repeatedly switching on and off within a short period of time and enables the use of a slower PLC.

The delay is increased by the configured time by switching the switching output to ON.

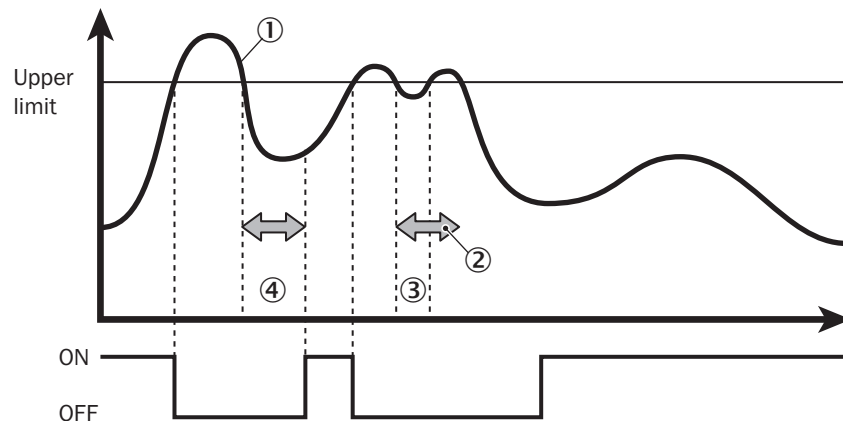


Figure 54: On Delay

① Measured value

- ② Shorter than the defined time period
- ③ The measured value is of equal size or greater than the threshold
Output switches to OFF
- ④ The measured value is below the threshold
Output switches to ON

Values are possible from 0 ms (default value) to 100 ms.

7.3.7.8 Setting the switch-off delay (Off Delay)

This setting is used to delay the switching off of the output by a set amount of time if the measured value falls below the threshold.

This function suppresses short signals (bursts) which prevents inaccurate measurements.

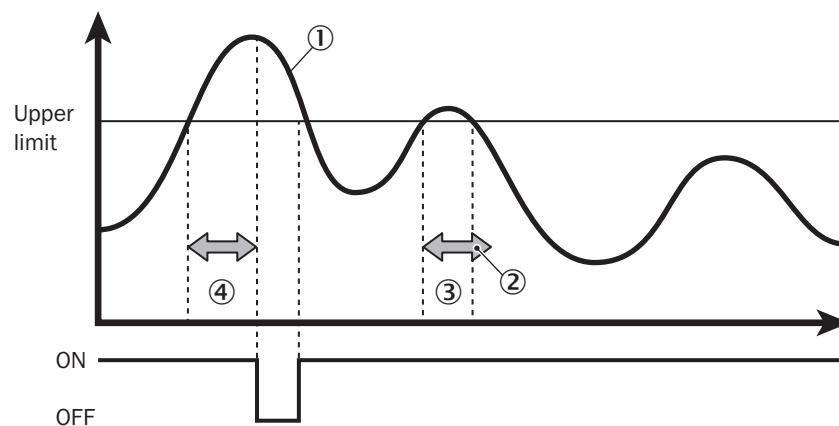


Figure 55: Off Delay

- ① Measured value
- ② Shorter than the defined time period
- ③ Output switches to OFF
- ④ Output switches to ON

Values are possible from 0 ms (default value) to 4,000 ms.

7.3.7.9 Setting the calibration

The display for setting the calibration will vary depending on the settings in the **Measurement** tab.

Distance

Shift

This setting is used to move the measured value to a fixed value. A corresponding correction value (shift) is added to or subtracted from the measured value of the sensor head.

Span

This value is selected according to the ratio of the measurement error to the measuring range. It is used for:

- compensating for a deviation caused by a tilted installation (distance)
- measuring the thickness of glass (so that refraction may be taken into account)

In a distance measurement, both values must usually be adjusted. With the thickness measurement type (for measuring the thickness of glass), it is important to set the calibration factor (span) to the correct value to ensure a precise measurement and to compensate for the refraction index of the measured material. Only the span value can be set for the thickness measurement.

Teaching-in is a recommended process. For the distance measurement, two different objects which are far apart must be placed in front of the sensor – the distances (reference values) must be known.

Teaching-in the distance measurement

Calibration

Current measurement value (mm)

0.1995 mm

Target value 1 (mm)

0.1990 mm **TEACH POINT 1**

Target value 2 (mm)

0.0000 mm **TEACH POINT 2**

Span

1

Shift

0.0000 mm

RESET

1. Position the first object.
2. Enter the current measured value for the first object in **Target value 1**.
3. Click on the **Teach-in point 1** button.
4. Position the second object.
5. Add target value 1 to the reference thickness of the second object and enter the result in **Target value 2**.

Teaching-in for thickness measurement

Calibration

Current measurement value (mm)

0.3691

mm

Reference thickness (mm)

0.3000

mm

TEACH

Span

1

RESET

1. Position object with a known reference thickness in front of the sensor.
2. Enter the reference thickness in the **Reference thickness** field.
3. Click on the **Teach-in** button.
- ✓ The sensor calculates the suitable span value and applies this to the measurement.



NOTE

The span and shift values can be adjusted manually at any time after the teach-in.

7.3.7.10 Setting One shot

If this function is activated, the output is only given once when the conditions for output are met. The output is then switched off.

The output time is set via the switch-off delay (off delay). The switch-on delay (on delay) can still be used in this mode.

7.3.8 I/O settings input (MF)

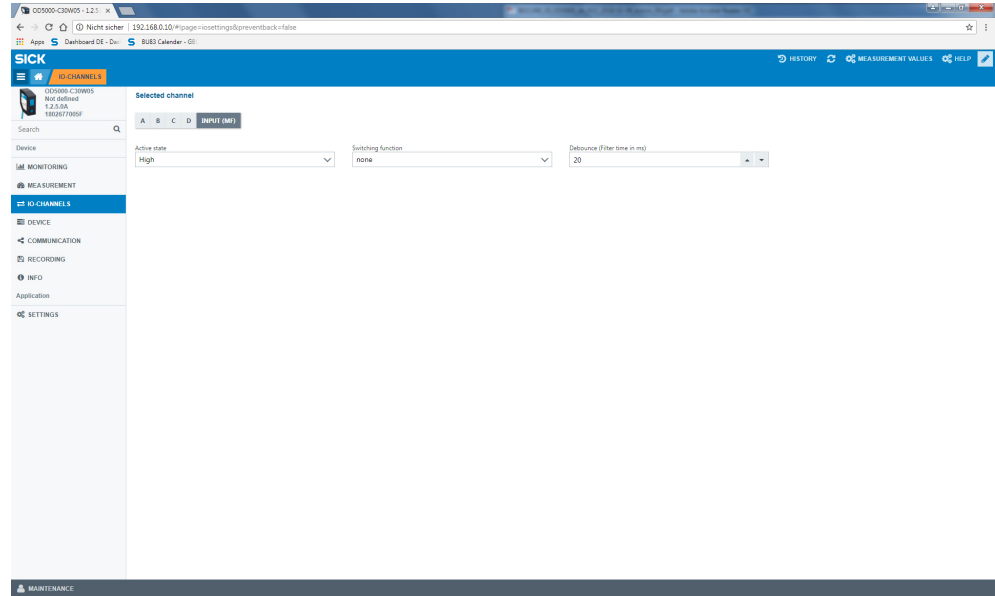


Figure 56: Tab showing the overview of the I/O settings of input (MF)

7.3.8.1 Setting the polarity

This is where the polarity is set for the external input terminal.

Table 19: Input terminal settings

Setting	Meaning
High	Switches on when input is detected
Low	Switches off when input is detected

High (N.O.) is set by default.

7.3.8.2 Setting the switching function

This is where the function is set for the external input terminal.

Table 20: Switching function settings

Setting	Meaning
None	Input (MF) is not used (input is ignored)
Laser off	Laser is switched off during input
Hold function ON/reset	Used as hold input/reset input when the hold function is activated For Peak Hold/Bottom Sample Hold: Hold input For Auto Peak Hold/Auto Bottom Hold: Reset input
Start process recording	Used as a recording input Recording is carried out when activated. When the specified amount of saved entries is reached, the recording is stopped and a file is created. If the input setting is set to OFF during the recording, the process is paused and a file is created using the data saved up until that point.
Measured value offset	Used as an Offset or as an Offset Release Input Less than 1 s: Offset 1 s or more: Offset compensation

The default mode is **None**.

7.3.8.3 Setting the debounce

Sets the delay time with which the external input is switched on until actual operation begins. This prevents the external input from suddenly being switched on or off.

Values are possible from 0 ms to 32,767 ms, the standard value is 20,000 ms.

7.3.9 Device

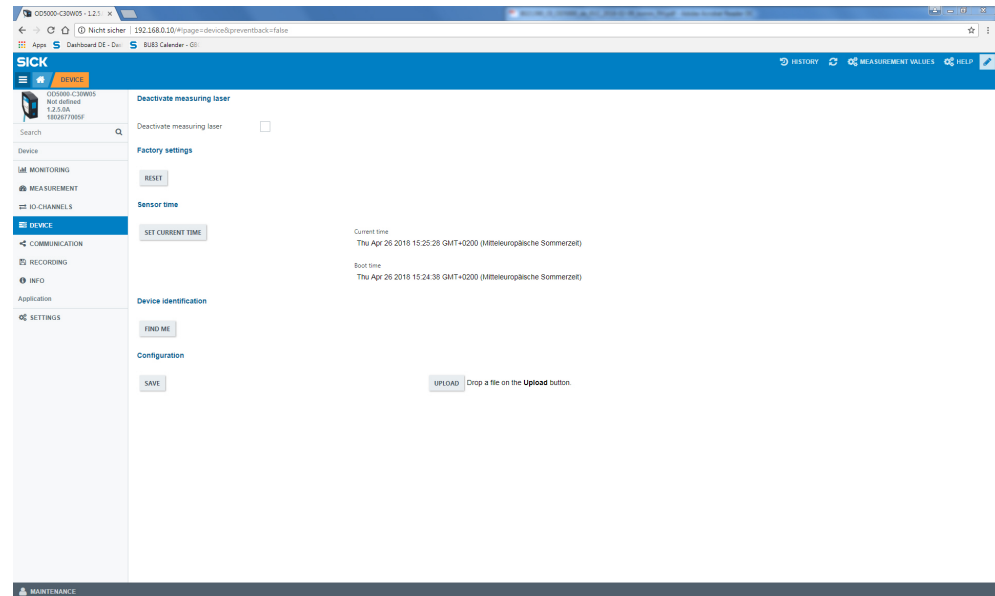


Figure 57: Overview of the Device tab

General device settings can be made in this view. The following functions are available here:

7.3.9.1 Deactivating the measurement laser

Checking or unchecking the box next to **Deactivate measurement laser** activates and deactivates the laser. If the laser is deactivated then measurement stops as a result. The laser is activated as standard.

7.3.9.2 Resetting the device to factory settings

Selecting this function resets all device settings to their factory settings. This does not include network settings (e.g., IP addresses). A subsequent device restart (power reset) is recommended.

7.3.9.3 Setting the sensor time

This section displays the current time as well as the time at which the device was started. Clicking on the **Set current time** button adjusts the device time to the time set on the computer being used.

7.3.9.4 Device identification (find me)

When this function is selected, the status LED of the device in question flashes for 5 s.

7.3.9.5 Saving the configuration

When this function is selected, the entire device configuration is saved in a file and prepared for download. A save location must be selected for the file.

**NOTE**

The default save location is normally the download folder (this depends on the individual browser settings).

7.3.9.6 Loading the configuration

When this function is activated, a previously stored OD5000 configuration file must be selected from the computer being used. This is then uploaded to the device and all settings are adopted accordingly.

7.3.10 Communication

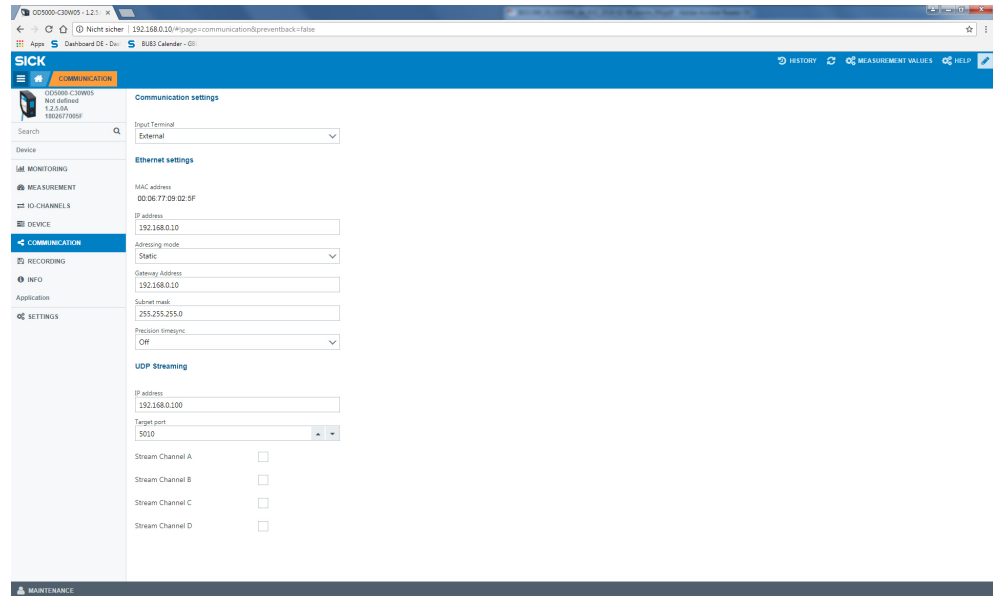


Figure 58: Overview of the Communication tab

Settings which affect communication received from or sent to the device can be made in this view. The following settings are available here:

7.3.10.1 Communication settings

Input settings

This is where the MF access is assigned a function.

The possible selection includes:

- External Input: The MF access is used for the selected switching function, see ["Setting the switching function", page 54](#).
- AOD1: The OD5000 can be connected with an AOD1 evaluation unit via its pins RS485+/RS485- (see ["Pin assignment of the connections", page 27](#)).

**NOTE**

Only one channel (A) can be used when AOD1 is selected.

Data transmission

This area can be used to set how data (see ["Operation via Ethernet", page 61](#)) should be transmitted.

- Target IP address for receiving process data (no default)
- Target port for receiving process data (default: 5010)
Selection between channels A-D

**NOTE**

When selecting the IP address and the port, take into account the conditions of your local network. They must be in the receivable range.

7.3.10.2 Network settings

Ethernet settings are also defined from the Communication tab.

MAC address

The device-specific MAC address is displayed in this field.

IP address

The device IP address is defined in this field.

The default value is 192.168.0.1.

Addressing mode

The user can choose between a static IP address and DHCP (default value) in this field.

Subnet mask

The device subnet mask is defined in this field.

The default value is 255.255.255.0.

Standard gateway

The standard gateway of the device is defined in this field.

The default value is 0.0.0.0.

Accurate time synchronization

A device of the OD series is defined as a time server in this field. This allows the internal clock within all the connected sensors to be synchronized precisely via the standardized precision time protocol (PTP). In this function, a device of the OD series must be defined as a master; all additional sensors must be defined as a slave.

This procedure is necessary when **Synchronous** or **Anti interference** is set as the synchronization mode.

Table 21: Accurate time synchronization modes

Mode	Meaning
Off (default value)	Function has been deactivated
Master	Device is defined as master
Slave	Device is defined as slave

**NOTE**

If a device on the network is already defined as a PTP time server then this must be used and all OD devices must be defined as slaves. Otherwise, synchronization cannot be executed properly.

7.3.11 Recording

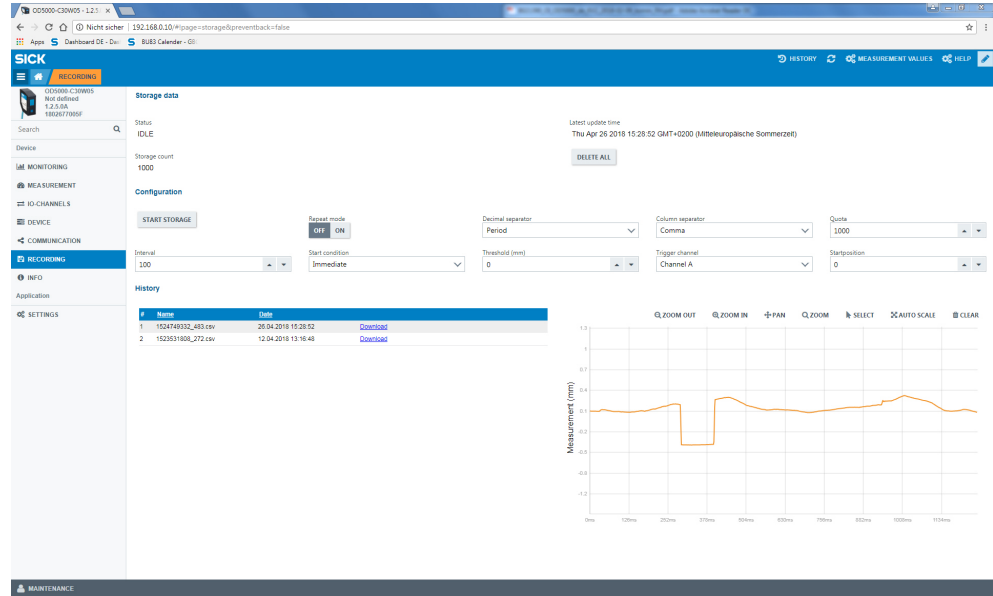


Figure 59: Overview of the Recording tab

Recording is used to prepare measurement data for storage. Output is in the form of a *.csv file. Saved data is listed and can be downloaded to the corresponding list entry at the click of a button. The exact download process depends on the individual browser settings.

Various functions are available via this display.

7.3.11.1 Formatting settings

In the **Decimal separator** field, the user can select whether the measured values in the *.csv file use a period or a comma as a decimal separator.

In the **Column delimiter** field, the user can select whether the data columns in the *.csv file are separated by a comma or semicolon.

**NOTE**

*.csv files become illegible if a comma is used as both a decimal separator and column delimiter.

7.3.11.2 Starting and testing the recording

Start recording

Clicking on the **Start recording** button starts the recording of the measurement data.

Test recording

Clicking on the **Test run** button starts a single recording. A previously set number of data entries are collected before data recording stops. Using this function, current measurement data can be collected and stored flexibly.

7.3.11.3 Determining the allocation

In the Allocation field, the user can define the number of data entries to be saved until the memory function is stopped. Values are possible from 1 to 100,000; the standard value is 1,000.

7.3.11.4 Setting the interval

The intervals at which data is to be saved is set in this field. This means that data is only saved periodically, thereby reducing the total quantity of stored data and simplifying any further processing.

If the value is set to 0 then all data is saved.

For values (n) greater than 0, only every nth measured value is saved.

Values are possible from 0 to 100,000; the standard value is 100.

7.3.11.5 Setting the start conditions

The following settings are possible:

Table 22: Settings for the recording start condition

Function	Meaning
Immediately (default value)	Memory function starts immediately
Error off	Memory function starts as soon as measurements are possible
Error on	Memory function starts as soon as measurements are not possible
Upper threshold	Memory function starts when measured values exceed the threshold
Lower threshold	Memory function starts when measured values fall below the threshold
Both thresholds	Memory function starts when measured values exceed or fall below the threshold

7.3.11.6 Defining the threshold

The threshold must be defined when one of the following modes is set as the start condition:

- Upper threshold
- Lower threshold
- Both thresholds

Values of $\pm 2,000.000$ mm are possible; the default value is 0.

7.3.11.7 Defining the trigger channel

The target output is defined in this field when the trigger for the start of the memory function is defined.

The options are Channel A (default value), B, C, or D.

7.3.11.8 Setting the start position

Indicates by how many measuring points the start of the recording is to be delayed when the start condition is met.

The following modes are possible:

Table 23: Start position settings

Setting	Meaning
Positive value	Delayed by the specified number of measurements and then starts the memory function
0	Starts the memory function as soon as the start condition is met
Negative value	Starts the saving function and considers the specified number of measured values which preceded fulfillment of the start condition

Values of ±50,000 are possible; the default value is 0.

7.3.11.9 View process

All recorded measurements are listed in this table.

By clicking on the underlined link with the file name of the measurement, the measurement file can be downloaded in CSV format (values separated by commas).

By clicking in the rows of the corresponding measurement outside of the link, the measurement process is displayed on the page.

There is a column for the sensor status in the measurement file. It contains a string with 20 characters and has the following meaning:

LAI- Hiz1 Hiz2 Hiz3 Hiz4L

Table 24: Sensor status

Code	Meaning
L	Laser on
A	Alarm on
I	External input status
-	Reserved
H	Hold status
i	Invalid measurement data
z	Zero set status
Channel number	Output status {number, l, g, h}
Number	Switch on output
l	Below the lower limit
h	Above the upper limit
g	Between lower and upper limit

7.3.12 Info

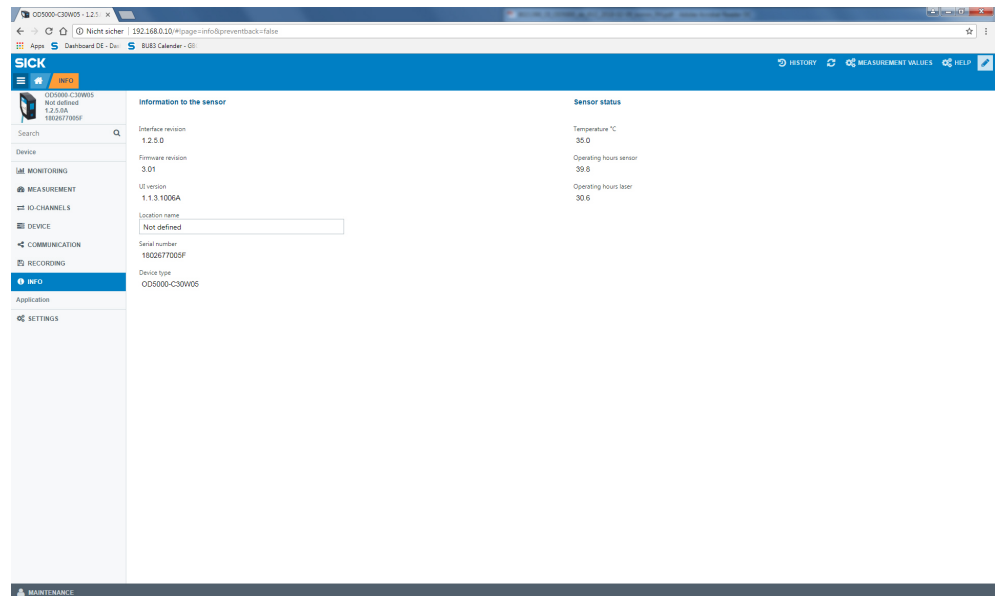


Figure 60: Overview of the Info tab

Via this display, the device status can be checked and information can be displayed.

Information on the sensor

The following device information is displayed:

- Interface version
- Firmware version
- mSDD version
- Temperature
- Sensor operating hours
- Laser operating hours
- Serial number
- Device type

Site

Text can be entered into the **Site** field, which is then used to trace the mounting site of the sensor.

7.3.13 Expert

More advanced settings can be made in the **Expert** tab. This tab is only available after having logged in with the **Service** user level. Settings in this level may only be made by qualified and authorized service personnel from SICK AG.

7.3.14 Settings**7.3.14.1 Selecting a language**

The language used in the SOPASair interface can be changed under **Settings**. The user can choose between:

- German
- English (default value)

**NOTE**

The interface must be reloaded after a new language has been selected.

7.3.14.2 Selecting the display mode

The user can choose between different display modes for the configuration interface. These provide an optimized display which is suitable for the end device:

- Phone
- Tablet
- Desktop (default value)

7.4 Operation via Ethernet

Measured values can be read out via the Ethernet interface and parameters can also be checked and adjusted.

Table 25: Parameters for Ethernet

Parameter	Value
Protocol	UDP (multicast, broadcast)
Port number	5010 (data transmission) 5011 (control)
Byte sequence	Big endian

**NOTE**

IP address and port number can be adjusted to the user, see "Communication settings", page 56).

7.4.1 Reading and writing data

Commands for reading and writing are transmitted to port 5011 via the UDP.

Reading

Table 26: Read request

0x30	0x06	0x00	0x00	Command (2 bytes)	Data length (2 bytes)
------	------	------	------	-------------------	-----------------------

Table 27: Read response

0xBn	nn (data length)	Response data (nnn bytes)
------	------------------	---------------------------

The data length identifies the number of response bytes that the user would like to read. This is limited to a maximum of 4,095 bytes (0x0FFF). The maximum is also limited by the network's Maximum Transmission Unit (MTU). This is usually 1,500 bytes for the Ethernet.

The response telegram contains the returned data lengths (without the two leading bytes which designate the response indicator 0xB and the length itself).

If exactly 4 bytes are requested then an abbreviated read request is possible:

Table 28: Short read request

0x30	0x02	Command (2 bytes)
------	------	-------------------

Table 29: Short read response

0xB0	0x04	Response data (4 bytes)
------	------	-------------------------

Example: Reading out measured values from channel A (short)

Read request: 0x3002 0x0D60

Read response: 0xB004 0x0012D687 (4 bytes are output with the value nnnnnn nm)

Example: Reading out user-defined application tag

Read request: 0x3006 0x0000 0x0160 0x001E

Read response: 0xB01E (30 characters for user-defined application tag)

Writing

Table 30: Write request

0x40	0x02	Command (2 bytes)	Onnn (data length)	Writing data (nnn bytes)
------	------	-------------------	--------------------	--------------------------

Table 31: Write response

0xC0	0x00
------	------

The data length identifies the number of response bytes that the user would like to write. This is limited to a maximum of 4,095 bytes (0x0FFF). The maximum is also limited by the network's Maximum Transmission Unit (MTU). This is usually 1,500 bytes for the Ethernet.

Example: Setting the sampling rate to 100 μ s

Write request: 0x4002 0x0C10 0x0004 0x00000003

Write response: 0xC000

Example: Determining user-defined application tag

Write response: 0x4002 0x0160 0x001E (30 characters for user-defined application tag)

Write response: 0xC000

7.4.2 Command list

The following commands can be accessed at port 5011 via the UDP interface. The parameters are always saved as 4-byte values in the big-endian format unless specified otherwise (with the most significant value in the memory first).

7.4.2.1 Outputting measured values

Table 32: Command list for sensor status and measured values

Access	Command	Name	Parameter	Comments
R	0x0D60	Value of channel A displacement		
R	0x0D64	Value of channel B displacement		
R	0x0D68	Value of channel C displacement		
R	0x0D6C	Value of channel D displacement		
R	0x0DA0	Channel A output status	*1	
R	0x0DA4	Channel B output status	*1	
R	0x0DA8	Channel C output status	*1	
R	0x0DAC	Channel D output status	*1	
R	0x01F4	Sensor status	*2	

Explanation of the bits relating to *1 (status of channel A/B/C/D)

Table 33: Explanation of the bits relating to *1 (status of channel A/B/C/D)

Bit	Comments
1 (0x0001)	Channel switched on/off (corresponding to setting in 0x0200 / 0x0280 / 0x0300 / 0x0380)
2 (0x0002)	Channel output rate (output state)
3 (0x0004)	Measured value of channel valid (0) / invalid (1)
4 (0x0008)	Unused, always 0
5 (0x0010)	Zero teach of channel off (0) / on (1)
6 (0x0020)	Hold function of channel off (0) / on (1)
7 (0x0040)	Unused, always 0
8 (0x0080)	
9 (0x0100)	Measured value of channel lower than lower switching threshold
10 (0x0200)	Measured value of channel between switching thresholds
11 (0x0400)	Measured value of channel higher than upper switching threshold

Bit	Comments
12 ... 32 (0x0800 ... 0x80000000)	Unused, always 0

Explanation of the bits relating to *2 (sensor status)

Table 34: Explanation of the bits relating to *2 (sensor status)

Bit	Comments
1 (0x0001)	Always at (1)
2 (0x0002)	Output value of channel A (output state)
3 (0x0004)	Measured value of channel A valid (0) / invalid (1)
4 (0x0008)	Unused, always 0
5 (0x0010)	Zero teach of channel A off (0) / on (1)
6 (0x0020)	Hold function of channel A off (0) / on (1)
7 (0x0040)	Unused, always 0
8 (0x0080)	
9 (0x0100)	Measured value of channel A lower than lower switching threshold
10 (0x0200)	Measured value of channel A between switching thresholds
11 (0x0400)	Measured value of channel A higher than upper switching threshold
12 ... 16 (0x0800 ... 0x8000)	Unused, always 0
17 (0x00010000)	Output value of channel A (output state) (Identical to bit 2)
18 (0x00020000)	Output value of channel B (output state)
19 (0x00040000)	Output value of channel C (output state)
20 (0x00080000)	Output value of channel D (output state)
21 ... 24 (0x00100000 ... 0x00800000)	Unused, always 0
25 (0x01000000)	Output state of external input
26 ... 27 (0x02000000 ... 0x04000000)	Unused, always 0
28 (0x08000000)	All measured values of channels A ... D valid (0) / at least one measured value invalid (1)
29 (0x10000000)	Precision time sync off (0) / on (1)
30 (0x20000000)	Memory for recording available (0) / full (1)
31 (0x40000000)	Laser off (0) / on (1)
32 (0x80000000)	Unused, always 0



NOTE

Sensor status of bits 2 ... 16 is identical to status of channel A bits 2 ... 16.

7.4.3 Measurement

7.4.3.1 Selecting default settings

Table 35: Command list for default settings

Access	Command	Name	Parameter	Comments
R/W	0x0CA0	Mounting	0x00: Diffuse 0x01: Specular	
R/W	0x0CA8	Synchronization mode	0x00: None 0x01: Synchronous 0x02: Anti-interference 1 0x03: Anti-interference 2	
R/W	0x0C10	Sampling rate	0x00: 12.5 0x01: 25 0x02: 50 0x03: 100 0x04: 200 0x05: 500 0x06: 1000 0x09: Auto	Unit: μ s
R/W	0x0C28	Tailoring the measured values	0x00: Near 0x01: Center 0x02: Far	Can only be used when a detection duration of 12.5 μ s is selected
R/W	0x0C14	Automated duration of sampling: Upper limit value	0x01: 25 0x02: 50 0x03: 100 0x04: 200 0x05: 500 0x06: 1000	Can only be used when automated detection duration is selected
R/W	0x0C18	Automated duration of sampling: Lower limit value	0x01: 25 0x02: 50 0x03: 100 0x04: 200 0x05: 500 0x06: 1000	Can only be used when automated detection duration is selected
R/W	0x0C48	Order of sampling	0x00: Near 0x01: Far	
R/W	0x0CA4	Measurement direction	0x00: Positive 0x01: Negative	
R	0x0400	Waveform	*3	1024 bytes
R	0x0D14	Peak position 1 in waveform	*4	
R	0x0D18	Peak position 2 in waveform	*4	
R	0x0D1C	Peak position 3 in waveform	*4	
R	0x0D20	Peak position 4 in waveform	*4	
R	0x0D24	Peak position 5 in waveform	*4	
R	0x0D28	Peak position 6 in waveform	*4	

Access	Command	Name	Parameter	Comments
R	0x0D2C	Peak position 7 in waveform	*4	
R	0x0D30	Peak position 8 in waveform	*4	
R/W	0x0C44	Waveform mask ON/OFF	0x00: OFF 0x01: ON	
R/W	0x0C60	Mask 1 starting position	Range 0 ... 511 (0x00000000 ... 0x000001FF)	Pixel number at which the mask starts
R/W	0x0C64	Mask 1 end position	Range 0 ... 511 (0x00000000 ... 0x000001FF)	Pixel number at which the mask ends
R/W	0x0C68	Mask 2 starting position	Range 0 ... 511 (0x00000000 ... 0x000001FF)	Pixel number at which the mask starts
R/W	0x0C6C	Mask 2 end position	Range 0 ... 511 (0x00000000 ... 0x000001FF)	Pixel number at which the mask ends
R/W	0x0C70	Mask 3 starting position	Range 0 ... 511 (0x00000000 ... 0x000001FF)	Pixel number at which the mask starts
R/W	0x0C74	Mask 3 end position	Range 0 ... 511 (0x00000000 ... 0x000001FF)	Pixel number at which the mask ends
R/W	0x0C78	Mask 4 starting position	Range 0 ... 511 (0x00000000 ... 0x000001FF)	Pixel number at which the mask starts
R/W	0x0C7C	Mask 4 end position	Range 0 ... 511 (0x00000000 ... 0x000001FF)	Pixel number at which the mask ends

*3: Explanation of the returned value (waveform)

The received waveform is returned as an array of 512 values (16 bits unsigned) which represents the light intensity of each pixel of the receiver.

*4: Explanation of the returned value (peak position in the waveform)

The returned value represents the number of pixels of the receiver (upper 2 bytes) and fraction between two pixels (lower 2 bytes).

Default settings per measurement channel

Table 36: Command list for default settings per measurement channel

Access	Command				Name	Parameter	Comments
	Channel A	Channel B	Channel C	Channel D			
R/W	0x0200	0x0280	0x0300	0x0380	Channel usage	0x00: Disable 0x01: Enable	
R/W	0x0204	0x0284	0x0304	0x0384	Measurement method	0x00: Distance 0x01: Thickness	

Access	Command				Name	Parameter	Comments
	Channel A	Channel B	Channel C	Channel D			
R/W	0x0208	0x0288	0x0308	0x0388	Peak number	0x00: No. 1 peak to 0x07: No. 8 peak	
R/W	0x020C	0x028C	0x030C	0x038C	Peak number 2 (for thickness measurement)	0x00: No. 1 peak to 0x07: No. 8 peak	Can only be used when thickness measurement is selected
R/W	0x0220	0x02A0	0x0320	0x03A0	Measurement offset	*5	
R/W	0x0234	0x02B4	0x0334	0x03B4	Execute teach	0x00: None 0x01: Execute offset 0x02: Clear offset	Also used to execute span teach. Is returned in response to read requests when teach is being executed

*5: Explanation of the parameters (measurement offset)

The applied parameter (in nm) is added to the raw displacement measurement. Alternatively, after a zero set operation has been executed, this parameter contains the calculated offset.

7.4.3.2 Making the settings for channels A–D

Table 37: Command list for the settings for channels A–D

Access	Command				Name	Parameter	Comments
	Channel A	Channel B	Channel C	Channel D			
R/W	0x0210	0x0290	0x0310	0x0390	Median filter	0x01: Not used (1) 0x07: 7 0x0F: 15 0x1F: 31	
R/W	0x0214	0x0294	0x0314	0x0394	Moving average	Range 2 ⁿ (n = 0...16)	

Access	Command				Name	Parameter	Comments
	Channel A	Channel B	Channel C	Channel D			
R/W	0x022C	0x02AC	0x032C	0x03AC	Hold mode	0x00: OFF 0x01: Peak 0x02: Bottom 0x03: Sample Hold 0x04: Auto Peak 0x05: Auto Bottom 0x06: Peak to Peak 0x07: Normal	
W	0x0238	0x02B8	0x0338	0x03B8	Hold version	0x00: None 0x01: Hold ON 0x02: Hold OFF 0x03: Hold reset	
R/W	0x0260	0x02E0	0x0360	0x03E0	Alarm	0x00: Clamp 0x01: Hold 0x02: Delay clamp	
R/W	0x0264	0x02E4	0x0364	0x03E4	Clamp value during alarm	Range -2,000,00 0,000 ... +2,000,00 0,000	Unit: nm Can only be used when clamp or clamp delay for alarm is selected
R/W	0x0268	0x02E8	0x0368	0x03E8	Number of measurements for delayed alarm	Range 0 ... 4095	Can only be used when clamp delay for alarm is selected
R/W	0x026C	0x02EC	0x036C	0x03EC	Number of measurements to be restored after alarm	Range 2^n (n = 0...16)	

7.4.4 I/O settings

7.4.4.1 Configuring channels A–D

Table 38: Command list for channels A–D

Access	Command				Name	Parameter	Comments
	Channel A	Channel B	Channel C	Channel D			
R/W	0x0244	0x02C4	0x0344	0x03C4	Upper limit	Range -2,000,00 0,000 ... +2,000,00 0,000	Unit: nm
R/W	0x0248	0x02C8	0x0348	0x03C8	Lower limit	Range -2,000,00 0,000 ... +2,000,00 0,000	Unit: nm
R/W	0x024C	0x02CC	0x034C	0x03CC	Hysteresis	Range -2,000,00 0,000 ... +2,000,00 0,000	Unit: nm
R/W	0x0254	0x02D4	0x0354	0x03D4	One shot	0x00: OFF 0x01: ON	
R/W	0x0258	0x02D8	0x0358	0x03D8	ON Delay time	Range 0 ... 4,000,000	Unit: μ s
R/W	0x025C	0x02DC	0x035C	0x03DC	OFF Delay time	Range 0 ... 4,000,000	Unit: μ s If One Shot is activated, this value refers to the time which must pass before the output channel may be reset
R/W	0x0218	0x0298	0x0318	0x0398	ObSB tolerance	Range 0 ... 2,000,000 ,000	Unit: nm Can only be used if output mode is set to ObSB

Access	Command				Name	Parameter	Comments
	Channel A	Channel B	Channel C	Channel D			
R/W	0x0224	0x02A4	0x0324	0x03A4	Calibration span	Range -2,000,00 0 ... +2,000,00 0 Values within the range -99,999 to +99,999 are invalid	Applied factor multiplied by 1,000,00 0 (e.g., factor 1 → 1,000,00 0)
R/W	0x0228	0x02A8	0x0328	0x03A8	Calibration shift	Range -2,000,00 0,000 ... +2,000,00 0,000	Unit: nm
R/W	0x0230	0x02B0	0x0330	0x03B0	Reference thickness	Range 0 ... 2,000,000 ,000	Unit: nm Can only be used for the teach function when measuring thickness
R/W	0x0234	0x02B4	0x0334	0x03B4	Execute teach	0x00: None 0x03: Teach thickness measurement 0x04: Reset teach thickness measurement 0x05: Teach upper limit 0x06: Teach lower limit	Also used for teach for offset Is returned in response to read requests when teach is being executed
R/W	0x0240	0x02C0	0x0340	0x03C0	Output mode	0x00: Dt0 0x01: Window 0x02: ObSB 0x03: Edge height	

Access	Command				Name	Parameter	Comments
	Channel A	Channel B	Channel C	Channel D			
R/W	0x0250	0x02D0	0x0350	0x3D0	Change direction	0x00: Both 0x01: Up 0x01: Down	Can only be used in edge height mode
R/W	0x0270	0x02F0	0x0370	0x03F0	Cycle off-set	Department 1 ... 100,000	Can only be used in edge height mode

7.4.4.2 Configuring MF input

Table 39: MF input command list

Access	Command	Name	Parameter	Comments
R/W	0x0C90	Input polarity	0x00: N.O. 0x01: N.C.	
R/W	0x0C94	Input filter time	Parameter: Range 0 ... +32767	Unit: μ s
R/W	0x0C98	Input action	0x00: None 0x01: Laser off 0x02: Hold/reset 0x03: Recording start 0x04: Offset (Zeroing)	Can only be used when MF usage is set to external input
R/W	0x0CB0	MF usage	0x00: External input 0x01: AOD1 interface	

7.4.5 Device settings

Table 40: Command list for device settings

Access	Command	Name	Parameter	Comments
R/W	0x0C40	Switching on laser	0x00: ON 0x01: OFF	
W	0x004C	Resetting to factory settings	0x03E7	This command returns all settings to their factory settings (except for Ethernet settings)
R/W	0x0030	Sensor time		Unit: Unix epoch (seconds since Jan 1, 1970)
W	0x004C	Changing the time	0x03D4	This command sets the system time to the value of the sensor time
R	0x0100	Boot time		Unit: Unix epoch (seconds since Jan 1, 1970)
R	0x012C	System time		Unit: Unix epoch (seconds since Jan 1, 1970)
W	0x105C	Find-me function		Unit: ms

Access	Command	Name	Parameter	Comments
R/W	0x0160	User-defined application tag		30 bytes

7.4.6 Communication

Table 41: Command list for communication settings

Access	Command	Name	Parameter	Comments
R	0x0018	MAC address		6 bytes
R/W	0x0CBC	Precision time-sync	0x00: OFF 0x01: Slave 0x02: Master	

Other communication parameters (IP address, subnet mask...) can only be set via a web browser (SOPASair).

7.4.7 Saving data

Table 42: Command list for memory settings

Access	Command	Name	Parameter	Comments
R	0x0CC4	Recording count		
R	0x0CC8	Recording state	0x00: Stopped 0x01: Waiting 0x02: Trigger standby 0x03: Operating 0x04: Operation complete	
R	0x0CCC	Load Recording time		Unit: Unix epoch (seconds since Jan 1, 1970)
R/W	0x0CD0	Recording quota	Range 0 ... 100,000	
R/W	0x0CD4	Recording rate	Range 0 ... 100,000	
R/W	0x0CD8	Recording repeating	0x00: OFF 0x01: ON	
W	0x004C	Delete all storage files	0x024E	
R/W	0x0CDC	Recording start condition	0x00: Immediate 0x01: Alarm Off edge 0x02: Alarm Off edge 0x03: Threshold Up edge 0x04: Threshold Down edge 0x05: Threshold Both edge	
R/W	0x0CE0	Recording trigger channel	0x00: Ch.A 0x01: Ch.B 0x02: Ch.C 0x03: Ch.D	

Access	Command	Name	Parameter	Comments
R/W	0x0CE4	Recording trigger threshold	Range -2,000,000,000 .. +2,000,000,000	Unit: nm
R/W	0x0CE8	Recording start delay	Range -50,000 ... +50,000	If positive, start delay; if negative, number of preliminary samples
R/W	0x0CF0	Recording control	0x00: Stop 0x01: Start	
R	0x0110	File system free space		Unit: kByte
R	0x0114	File system capacity		Unit: kByte

7.4.8 Info

Table 43: Command list for reading information

Category	Command	Name	Parameter	Comments
R	0x0004	Firmware version		
R	0x0008	Software version		
R	0x0120	Temperature		Unit: 1/1000 °C
R	0x0124	Device operating time		Unit: s
R	0x0128	Laser operating time		Unit: s

7.4.9 Determining measured values using time specifications

In addition to the measured values, the associated time specifications are also required for some operations. Using the following command, the device supplies the measured values together with a time stamp and then outputs this information.

Table 44: Transmitted command

30	06	00	00	01	F0	00	0C
----	----	----	----	----	----	----	----

Table 45: Received command

B0	0C	Measured value (4 bytes)	Device status/ measurement result (4 bytes)	Time stamp (4 bytes)
----	----	-----------------------------	---	-------------------------

The time stamp is specified as a value between 0 ns and 999,999,999 ns which counts down after each measurement until it reaches 0. This means that the timing and the sequence of the individual measured values can be read.



NOTE

Receiving measured value with a time stamp is only possible for channel A (see "Obtaining data continuously", page 73 for options for receiving data with a time stamp for all channels).

7.4.10 Obtaining data continuously

The device permits measurement data to be continually obtained via the Ethernet User Datagram Protocol (UDP to port 5010). This mode permits this data to be used in real time applications or when user-defined memory mechanisms are implemented.

In this mode, the device transmits the measured values automatically at intervals of 1 ms. If detection times are used which are faster than 1 ms, each data transmission will contain several measured values.

In order to activate Push mode, a target must be available for the data push (target IP address, port) and a selection of data channels (channel A, B, C, and/or D).



NOTE

The device can transmit several channels at the same time.

The commands for configuring the push mode must be transmitted through control port 5011.

Table 46: Command list for data push

Access	Command	Name	Parameter	Comments
R/W	0x10E0	Data push port	*7	4 bytes Requires firmware version V3.08 or higher
R/W	0x10E2	Data push port	*7	2 bytes
R/W	0x10E4	Data push IP address	*8	
R/W	0x01E0	Data push channel selection	0x00: Stop Data Push 0x01 ... 0x0F: Start Data Push	Sets the measured value channel of the output by setting the following bits: Bit 0: Channel A Bit 1: Channel B Bit 2: Channel C Bit 3: Channel D
R/W	0x004C	Delete all storage file	0x24E	
R/W	0x0CA4	Measurement direction	0:Positive 1:Negative	

***7: Explanation of the parameters (data push port)**

The target IP port for the data push must be set as a 16-bit signed integer (0 to 65535). The port is usually selected automatically by the target computer when it initiates UDP communication to OD5000.

***8: Explanation of the parameters (data push IP address)**

The IP address in decimal format is set with a byte array (e.g., IP address 192.168.0.10 → write parameter is 0xC0 A8 00 0A).

The data format of the push data transmission is defined as follows:

Table 47: Meaning of the bytes

Byte no.	Length	Meaning
0 ... 1	2	Bits 15 to 12: Data push identifier 0xD bits 11 to 0: Length of the data frame (without bytes 0 to 1)
2 ... 5	4	Sensor status (see command 0x01F4)
6 ... 9	4	Time stamp of the first value (unit: ns) The time stamp of the remaining values must be ascertained on the basis of the detection period. The time stamp is reset to zero after every second.
10 ... 13	4	Measurement counter of the first value. The measurement counter determines whether measurements between two references were deleted.

Byte no.	Length	Meaning
14 ...	Various	The remaining data frame (as indicated by the length indicator in bytes 0 to 1) contains the measured values. Each measured value is displayed as a signed 32-bit value (big-endian). Each channel returns values which were collected in the previous 1 ms. The sequence is: (Channel first selected, oldest value) - (channel selected second, oldest value) ... - (channel selected last, oldest value) ... (Channel first selected, most recent value) - (channel selected second, most recent value) ... - (channel selected last, most recent value)

Example:

OD5000 with sampling rate of 100 μ s (10 measurements/1 ms)

The received push data package contains the information (0 to 13) and 20 measured values (10 per channel).

Table 48: Push data package information

Byte no.	Value (hex)	Meaning
[0]	D0	Push data identifier
[1]	5C	Data length (92 bytes)
[2]	40	Sensor status
[3]	00	
[4]	04	
[5]	01	
[6]	1D	Time stamp (498.592.366 ns)
[7]	B7	
[8]	EA	
[9]	6E	
[10]	00	Measurement counter (# 3810558)
[11]	3A	
[12]	24	
[13]	FE	
[14]	00	Channel A, first value (15,262,800 nm)
[15]	E8	
[16]	E4	
[17]	50	Channel B, first value (-5,243,400 nm)
[18]	FF	
[19]	AF	
[20]	FD	
[21]	F8	Channel A, second value (15,262,200 nm)
[22]	00	
[23]	E8	
[24]	E1	
[25]	F8	

Byte no.	Value (hex)	Meaning
[26]	FF	Channel B, second value (-5,243,400 nm)
[27]	AF	
[28]	FD	
[29]	F8	
...		
[86]	00	Channel A, final value (15,257,400 nm)
[87]	E8	
[88]	CF	
[89]	38	
[90]	FF	Channel B, final value (-5,242,200 nm)
[91]	B0	
[92]	02	
[93]	A8	

7.4.11 Error messages

Action in case of incorrect measurements

If a measurement cannot be run, an error is output. Possible causes of the error:

- The measuring object is outside of the measuring range.
- The light signal received by the device is not strong enough.
- The laser is switched off.

You can configure the device behavior for the event that no measurement is possible. The following options are available:

- **Error suppression time:** It is possible to set a time for which the last valid measured value or the error value is displayed and held.
- **Hold last value:** If no measurement is possible, the last valid measured value is displayed and held until a valid measured value is available again or for the duration of the specified error suppression time.
- **Substitute value in the event of an error:** If no measurement is possible, the specified replacement value is displayed and held until a valid measured value is available again or for the duration of the specified error suppression time.
- **Substitute value in the event of an error:** A numerical value can be entered which is output when no measurement is possible.

When an error occurs, the device sends an error message in the following format:

Table 49: Format of the error message

E0	02	Details of error
----	----	------------------

E0 02 Details of error

Table 50: Error messages

Name of error	Details of error	Details
Command error	0x00E1	The specified command does not exist
Address error	0x00E2	The specified address exceeds the permitted range
Overflow	0x00E9	Data overflow is returned

8 Maintenance

8.1 Maintenance

During operation, the device works maintenance-free.

Depending on the assignment location, the following preventive maintenance tasks may be required for the device at regular intervals:

Table 51: Maintenance schedule

Maintenance work	Interval	To be carried out by
Clean housing and front screen	Cleaning interval depends on ambient conditions and climate	Specialist
Check screw connections and plug connectors	Interval depends on the place of use, ambient conditions, or operational regulations. Recommended: At least every 6 months.	Specialist

8.2 Cleaning



NOTICE

Equipment damage due to improper cleaning.

Improper cleaning may result in equipment damage.

- Only use recommended cleaning agents.
 - Never use sharp objects for cleaning.
-
- ▶ Clean the front screens at regular intervals and in the event of contamination with a lint-free lens cloth (part no. 4003353) and plastic cleaning agent (part no. 5600006). The cleaning interval essentially depends on the ambient conditions.

9 Troubleshooting

9.1 General faults, warnings, and errors

General faults are subdivided into warnings and errors. Current measured values continue being output when there are warnings; measurement is no longer possible when there are faults.

Table 52: Troubleshooting questions and replies

Status	Solution
The device is not displaying a measurement.	<p>Check that the device laser is activated and that the laser light spot is aimed at the object.</p> <p>Make sure that the object is within the measuring range of the device.</p> <p>Check the light distribution curve. The light distribution curve shows whether the receiver element of the device is receiving light.</p> <p>In this case, the light distribution curve normally displays a maximum within the area shown. This graphic visualizes the remission of light onto the receiver element.</p>
No measurement possible.	Check the possible causes: Light path obscured / device not in measuring range / reflective surface.
The link LED is not illuminated.	Ethernet connection not possible. Check the Ethernet connection cables.

9.2 Detecting and displaying errors

In addition to measurement errors, the device can also detect and display other errors. These are output by Sopas ET, IO-Link, or via the software user interface.

Error memory

The device has an error memory where its internal error states are recorded. The last error to have occurred is always saved. The content of the error memory is retained when the device is switched off and when the **Reset > Factory settings** function is used.

Possible errors

Table 53: Explanation of the error codes

Error code	SOPAS ET hex code / device status	Meaning	Countermeasure(s)
-	- / No signal	No measurement possible	Check the measuring range, increase the cycle time setting, or reduce the distance to the object; alternatively, please contact the manufacturer's technical support team
-	- / Laser switched off	Laser is deactivated	Activate laser
Temperature error	0x50 / Temperature error 0x10 / Temperature warning	Operating temperature undershot or exceeded	Check the ambient temperature and raise or lower it if necessary
Laser error	0x11 / Laser warning 0x60 / Laser error 1 0x61 / Laser error 2 0x62 / Laser error 3	Laser error	Please contact the manufacturer's technical support

Error code	SOPAS ET hex code / device status	Meaning	Countermeasure(s)
Internal error	0x80 / Internal error 1 0x81 / Internal error 2 0x82 / Internal error 3 0x83 / Internal error 4	Operating fault	Check the electrical environment and improve it, if necessary (stability, voltage supply, EMC influences). If the error cannot be rectified: Please contact the manufacturer's technical support.

If a different message is output, contact the manufacturer's technical support.

9.3 Information for service cases

You should collect and write down the following device information ahead of time if you need to contact the manufacturer's service department:

- Information about the firmware version
- Information about the hardware
- Information about operating hours

This information can be accessed via SOPAS AIR.

9.4 Returns

- ▶ Do not dispatch devices to the SICK Service department without consultation.
- ▶ The device must be sent in the original packaging or an equivalent padded packaging.



NOTE

To enable efficient processing and allow us to determine the cause quickly, please include the following when making a return:

- Details of the contact person
- Description of the application
- Description of the fault that occurred

9.5 Repairs

Repair work on the device may only be performed by qualified and authorized personnel from SICK AG. Interruptions or modifications to the device by the customer will invalidate any warranty claims against SICK AG.

10 Decommissioning

10.1 Disposal



CAUTION

Risk of injury due to hot device surface.

The surface of the device can become hot during operation.

- Before commencing disassembly, switch off the device and allow it to cool down as necessary.
-

Any device which can no longer be used must be disposed of in an environmentally friendly manner in accordance with the applicable country-specific waste disposal regulations. Do not dispose of the product along with household waste.



NOTICE

Danger to the environment due to improper disposal of the device.

Disposing of devices improperly may cause damage to the environment.

Therefore, observe the following information:

- Always observe the valid regulations on environmental protection.
 - Separate the recyclable materials by type and place them in recycling containers.
-

11 Technical data



NOTE

The relevant online data sheet for your product, including technical data, dimensional drawing, and connection diagrams can be downloaded, saved, and printed from the Internet:

- www.sick.com/OD5000

11.1 Performance

OD5000-C15xxx

Table 54: OD5000-C15xxx: Technical data for performance

	OD5000-C15W01 (Part no.: 6063620)	OD5000-C15T01 (Part no.: 6063619)
Specular reflection		
Laser type	Wide	Thin
Typical light spot size (center of the measuring range)	30 × 1,000 µm	∅ 30 µm
Measuring range	14 mm ... 16 mm	
Linearity (near side)	± 1 µm	
Linearity (far side)	± 1 µm	
General details		
Reproducibility	0.01 µm	
Response time	12.5 µs ¹⁾ / 25 µs / 50 µs / 100 µs / 200 µs / 500 µs / 1 ms / Auto	
Measuring frequency	≤ 80 kHz	
Light sender	Laser, red (visible, wavelength 655 nm, max. output: 0.39 mW)	
Laser class	1 (EN 60825-1:2014)	

¹⁾ At 12.5 µs, measurement is only possible in a sub-area, see "Setting the sampling duration", page 38.



NOTE

No diffuse reflection is possible with the OD5000-C15xxx. Observe the mounting instructions, see "Mounting device", page 23.

OD5000-C30xxx

Table 55: OD5000-C30xxx: Technical data for performance

	OD5000-C30W05 (Part no.: 6063622)	OD5000-C30T05 (Part no.: 6063621)
Diffuse reflection		
Laser type	Wide	Thin
Typical light spot size (center of the measuring range)	30 × 1,000 µm	∅ 30 µm
Measuring range	25 mm ... 35 mm	
Linearity (near side)	± 1.5 µm	± 3.0 µm
Linearity (far side)	± 1.5 µm	± 3.0 µm
Specular reflection		

	OD5000-C30W05 (Part no.: 6063622)	OD5000-C30T05 (Part no.: 6063621)
Laser type	Wide	Thin
Measuring range	22.5 mm ... 28.5 mm	
Linearity (near side)	± 4 µm	
Linearity (far side)	± 4 µm	
General details		
Reproducibility	0.05 µm	
Response time	12.5 µs ¹⁾ / 25 µs / 50 µs / 100 µs / 200 µs / 500 µs / 1 ms / Auto	
Measuring frequency	80 kHz	
Light sender	Laser, red (visible, wavelength 655 nm, max. output: 0.39 mW)	
Laser class	1 (EN 60825-1:2014)	

¹⁾ At 12.5 µs, measurement is only possible in a sub-area, see "Setting the sampling duration", page 38.

OD5000-C85xxx

Table 56: OD5000-C85xxx: Technical data for performance

	OD5000-C85W20 (Part no.: 6063624)	OD5000-C85T20 (Part no.: 6063623)
Diffuse reflection		
Laser type	Wide	Thin
Typical light spot size (center of the measuring range)	70 × 2,000 µm	ø 70 µm
Measuring range	85 ± 20 mm	85 ± 20 mm
Linearity (near side)	± 6 µm	± 7.2 µm
Linearity (far side)	± 6 µm	± 12 µm
Specular reflection		
Laser type	Wide	Thin
Measuring range	81.5 ± 10 mm	81.5 ± 10 mm
Linearity (near side)	± 6 µm	± 6 µm
Linearity (far side)	± 6 µm	± 6 µm
General details		
Reproducibility	0.1 µm	
Response time	12.5 µs ¹⁾ / 25 µs / 50 µs / 100 µs / 200 µs / 500 µs / 1 ms / Auto	
Measuring frequency	80 kHz	
Light sender	Laser, red (visible, wavelength 655 nm, max. output: 0.39 mW)	
Laser class	1 (EN 60825-1:2014)	

¹⁾ At 12.5 µs, measurement is only possible in a sub-area, see "Setting the sampling duration", page 38.

OD5000-C150xxx

Table 57: OD5000-C150xxx: Technical data for performance

	OD5000-C150W40 (Part no.: 6063626)	OD5000-C150T40 (Part no.: 6063625)
Diffuse reflection		
Laser type	Wide	Thin

	OD5000-C150W40 (Part no.: 6063626)	OD5000-C150T40 (Part no.: 6063625)
Typical light spot size (center of the measuring range)	120 × 4,000 μm	∅ 120 μm
Measuring range	150 ± 40 mm	150 ± 40 mm
Linearity (near side)	± 12 μm	± 24 μm
Linearity (far side)	± 12 μm	± 32 μm
General details		
Reproducibility	0.2 μm	
Response time	12.5 μs ¹⁾ / 25 μs / 50 μs / 100 μs / 200 μs / 500 μs / 1 ms / Auto	
Measuring frequency	80 kHz	
Light sender	Laser, red (visible, wavelength 655 nm, max. output: 0.39 mW)	
Laser class	1 (EN 60825-1:2014)	

¹⁾ At 12.5 μs, measurement is only possible in a sub-area, see "Setting the sampling duration", page 38.

11.2 Interfaces

Table 58: Technical data for interfaces

Ethernet	UDP/IP
Digital inputs	IN1 Can be used as laser off, external teach-in, or deactivated

11.3 Mechanics and electronics

Table 59: Technical data for mechanics and electronics

Supply voltage U_V	12 V DC ... 24 V (±10%, including residual ripple)
Power consumption	At 24 V (180 mA)
Warm-up time	< 10 min
Housing material	Aluminum die cast, acrylic glass (PMMA), with scratch-proof coating
Connection type	Cable with male connector M12, 8-pin, A-coded, 50 cm
Indicator	Status LEDs
Weight	280 g
Dimensions	see "Setup and dimensions", page 11
Enclosure rating	IP 67
Protection class	III in accordance with EN 50178

11.4 Ambient data

Table 60: Ambient data

Ambient operating temperature (air humidity)	-10 °C ... +50 °C ¹⁾ (35% to 85%)
Storage temperature (air humidity)	-20 °C ... +60 °C (35% to 85%)
Temperature drift	± 0.01% FS / °C (at -10 °C to +40 °C), ± 0.03% FS / °C (at +40 °C to +50 °C)

Type Ambient light immunity	Artificial light: $\leq 3,000 \text{ lx}^{2)}$ Sunlight: $\leq 10,000 \text{ lx}$
Vibration resistance	EN 60068-2-6 / EN 60068-2-64
Shock resistance	EN 60068-2-27

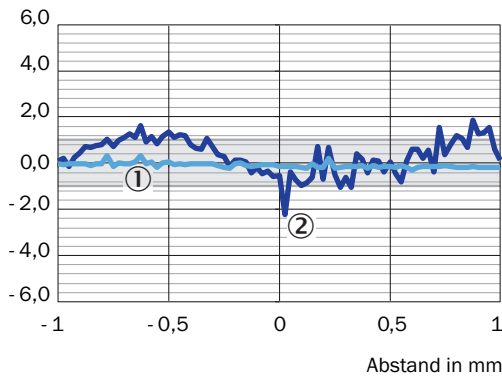
1) At $U_V = 24 \text{ V}$

2) With constant object movement in the measuring range

11.5 Linearity diagram

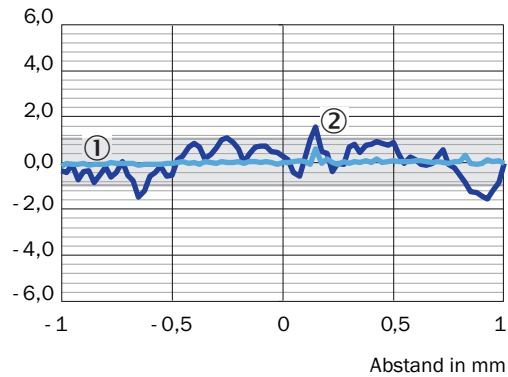
OD5000-C15Tx and OD5000-C15Wxx

Linearity in μm



- ① Glass
- ② Reflector

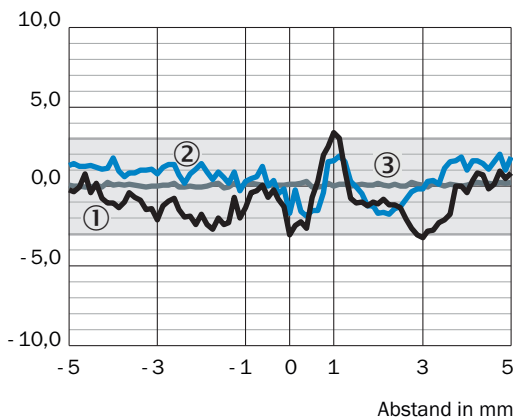
Linearity in μm



- ① Glass
- ② Reflector

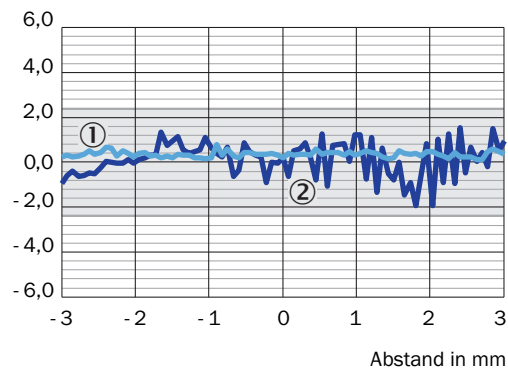
OD5000-C30Tx

Linearity in μm



- ① Rubber, black (10% remission)
- ② Ceramic, white (60% remission)
- ③ Stainless steel

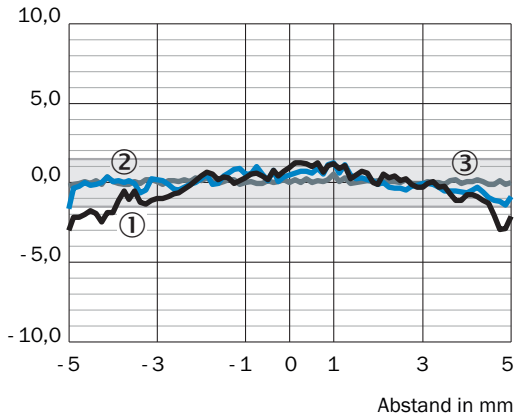
Linearity in μm



- ① Glass
- ② Reflector

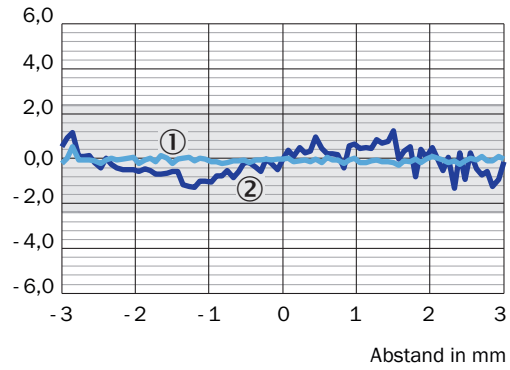
OD5000-C30Wxx

Linearity in μm



- ① Rubber, black (10% remission)
- ② Ceramic, white (60% remission)
- ③ Stainless steel

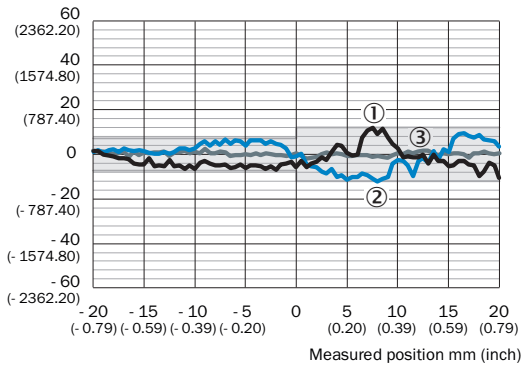
Linearity in μm



- ① Glass
- ② Reflector

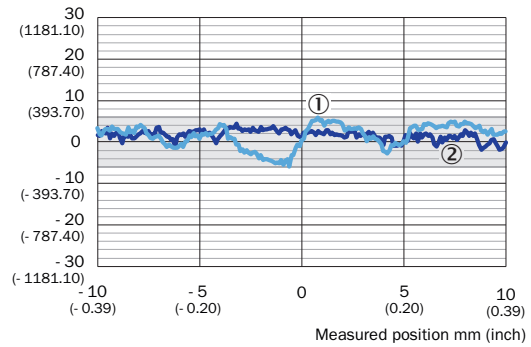
OD5000-C85Txx

Linearity μm (μin)



- ① Rubber, black (10% remission)
- ② Ceramic, white (60% remission)
- ③ Stainless steel

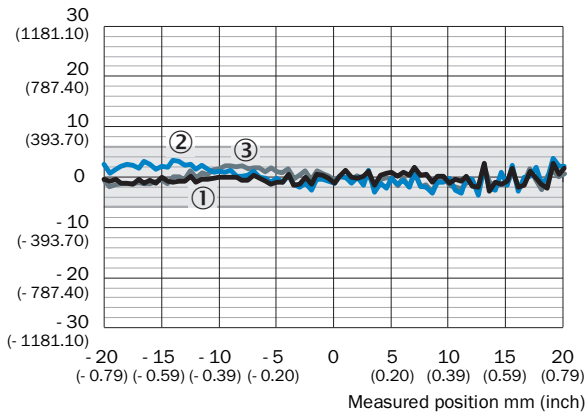
Linearity μm (μin)



- ① Glass
- ② Reflector

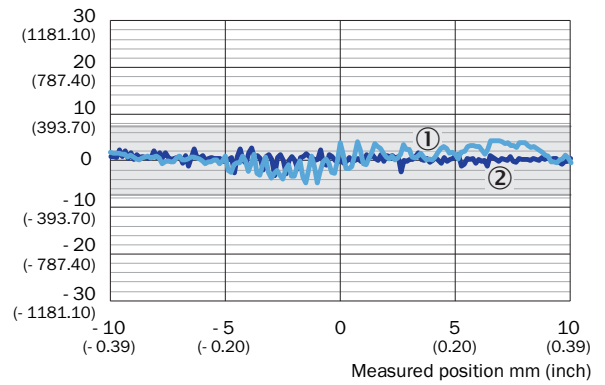
OD5000-C85Wxx

Linearity (µm)



- ① Rubber, black (10% remission)
- ② Ceramic, white (60% remission)
- ③ Stainless steel

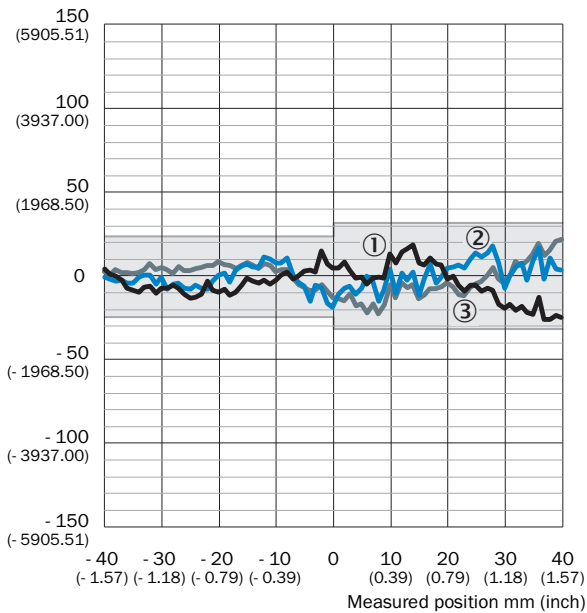
Linearity µm (µin)



- ① Glass
- ② Reflector

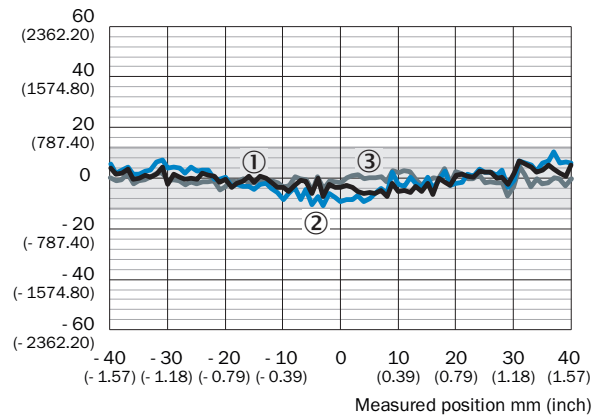
OD5000-C150Tx and OD5000-C150Wxx

Linearity µm (µin)



- ① Rubber, black (10% remission)
- ② Ceramic, white (60% remission)
- ③ Stainless steel

Linearity µm (µin)



- ① Rubber, black (10% remission)
- ② Ceramic, white (60% remission)
- ③ Stainless steel

12 Accessories



NOTE

Accessories and where applicable mounting information can be found online at:

- www.sick.com/OD5000

12.1 Recommended accessories

Designation	Model name	Part number
Y-distribution	SYL-1208-G0M	6064008
Y-distribution extension cable	DSC-1208-G02MA (2 m)	6064004
	DSC-1208-G05MA (5 m)	6064005
	DSC-1208-G10MA (10 m)	6064006
	DSC-1208-G30MA (30 m)	6064007
Supply cable	DOL-1204-G02MAC	2088079
Ethernet cable	SSL-2J04-G02ME	6034414
AOD1 connection cable	DSL-2804-G02MC	6039180

13 Annex

13.1 EU declaration of conformity / Certificates

The EU declaration of conformity and other certificates can be downloaded from the Internet at:

- www.sick.com/OD5000

13.2 Licenses

SICK uses open-source software. This software is licensed by the rights holders using the following licenses among others: the free licenses GNU General Public License (GPL Version2, GPL Version3) and GNU Lesser General Public License (LGPL), the MIT license, zLib license, and the licenses derived from the BSD license.

This program is provided for general use, but WITHOUT ANY WARRANTY OF ANY KIND. This warranty disclaimer also extends to the implicit assurance of marketability or suitability of the program for a particular purpose.

More details can be found in the GNU General Public License. View the complete license texts here: www.sick.com/licensetexts. Printed copies of the license texts are also available on request.

Australia

Phone +61 (3) 9457 0600
1800 33 48 02 – tollfree
E-Mail sales@sick.com.au

Austria

Phone +43 (0) 2236 62288-0
E-Mail office@sick.at

Belgium/Luxembourg

Phone +32 (0) 2 466 55 66
E-Mail info@sick.be

Brazil

Phone +55 11 3215-4900
E-Mail comercial@sick.com.br

Canada

Phone +1 905.771.1444
E-Mail cs.canada@sick.com

Czech Republic

Phone +420 2 57 91 18 50
E-Mail sick@sick.cz

Chile

Phone +56 (2) 2274 7430
E-Mail chile@sick.com

China

Phone +86 20 2882 3600
E-Mail info.china@sick.net.cn

Denmark

Phone +45 45 82 64 00
E-Mail sick@sick.dk

Finland

Phone +358-9-25 15 800
E-Mail sick@sick.fi

France

Phone +33 1 64 62 35 00
E-Mail info@sick.fr

Germany

Phone +49 (0) 2 11 53 01
E-Mail info@sick.de

Hong Kong

Phone +852 2153 6300
E-Mail ghk@sick.com.hk

Hungary

Phone +36 1 371 2680
E-Mail ertekesites@sick.hu

India

Phone +91-22-6119 8900
E-Mail info@sick-india.com

Israel

Phone +972-4-6881000
E-Mail info@sick-sensors.com

Italy

Phone +39 02 27 43 41
E-Mail info@sick.it

Japan

Phone +81 3 5309 2112
E-Mail support@sick.jp

Malaysia

Phone +603-8080 7425
E-Mail enquiry.my@sick.com

Mexico

Phone +52 (472) 748 9451
E-Mail mario.garcia@sick.com

Netherlands

Phone +31 (0) 30 229 25 44
E-Mail info@sick.nl

New Zealand

Phone +64 9 415 0459
0800 222 278 – tollfree
E-Mail sales@sick.co.nz

Norway

Phone +47 67 81 50 00
E-Mail sick@sick.no

Poland

Phone +48 22 539 41 00
E-Mail info@sick.pl

Romania

Phone +40 356-17 11 20
E-Mail office@sick.ro

Russia

Phone +7 495 283 09 90
E-Mail info@sick.ru

Singapore

Phone +65 6744 3732
E-Mail sales.gsg@sick.com

Slovakia

Phone +421 482 901 201
E-Mail mail@sick-sk.sk

Slovenia

Phone +386 591 78849
E-Mail office@sick.si

South Africa

Phone +27 (0)11 472 3733
E-Mail info@sickautomation.co.za

South Korea

Phone +82 2 786 6321
E-Mail info@sickkorea.net

Spain

Phone +34 93 480 31 00
E-Mail info@sick.es

Sweden

Phone +46 10 110 10 00
E-Mail info@sick.se

Switzerland

Phone +41 41 619 29 39
E-Mail contact@sick.ch

Taiwan

Phone +886-2-2375-6288
E-Mail sales@sick.com.tw

Thailand

Phone +66 2 645 0009
E-Mail marcom.th@sick.com

Turkey

Phone +90 (216) 528 50 00
E-Mail info@sick.com.tr

United Arab Emirates

Phone +971 (0) 4 88 65 878
E-Mail info@sick.ae

United Kingdom

Phone +44 (0)17278 31121
E-Mail info@sick.co.uk

USA

Phone +1 800.325.7425
E-Mail info@sick.com

Vietnam

Phone +65 6744 3732
E-Mail sales.gsg@sick.com

Further locations at www.sick.com