

KTS/KTX Prime

Contrast sensor

IO-Link Smart Task time stamp

SICK
Sensor Intelligence.



Described product

KTS/KTX Prime IO-Link Smart Task time stamp

Manufacturer

SICK AG
Erwin-Sick-Str. 1
79183 Waldkirch
Germany

Legal information

This work is protected by copyright. Any rights derived from the copyright shall be reserved for SICK AG. Reproduction of this document or parts of this document is only permissible within the limits of the legal determination of Copyright Law. Any modification, abridgment or translation of this document is prohibited without the express written permission of SICK AG.

The trademarks stated in this document are the property of their respective owner.

© SICK AG. All rights reserved.

Original document

This document is an original document of SICK AG.

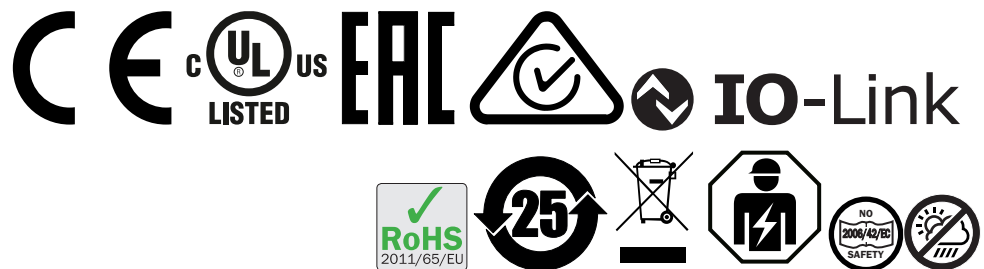

Contents

| | | |
|----------|---|-----------|
| 1 | About this document..... | 5 |
| 1.1 | Information on the operating instructions..... | 5 |
| 1.2 | Scope..... | 5 |
| 1.3 | Explanation of symbols..... | 5 |
| 1.4 | Further information..... | 6 |
| 1.5 | Customer service..... | 6 |
| 2 | Safety information..... | 7 |
| 2.1 | Intended use..... | 7 |
| 2.2 | Improper use..... | 7 |
| 2.3 | Limitation of liability..... | 7 |
| 2.4 | Requirements for skilled persons and operating personnel..... | 8 |
| 2.5 | Hazard warnings and operational safety..... | 8 |
| 2.6 | Repair..... | 9 |
| 3 | Product description..... | 10 |
| 3.1 | Product ID..... | 10 |
| 3.2 | Product features and functions..... | 11 |
| 4 | Mounting..... | 15 |
| 4.1 | Scope of delivery..... | 15 |
| 4.2 | Mounting requirements..... | 15 |
| 4.3 | Mounting the device..... | 15 |
| 5 | Electrical installation..... | 17 |
| 5.1 | Notes on the electrical installation..... | 17 |
| 5.2 | Note on the swivel connector..... | 18 |
| 5.3 | Pin assignment of the connections..... | 18 |
| 5.4 | Connecting the supply voltage..... | 18 |
| 5.5 | Wiring the interfaces..... | 19 |
| 6 | Commissioning..... | 22 |
| 6.1 | Simplified illustration..... | 22 |
| 7 | Operation..... | 24 |
| 7.1 | Operating elements..... | 24 |
| 7.2 | Navigation tree, general..... | 24 |
| 7.3 | Navigation tree, pro level (advanced settings)..... | 25 |
| 7.4 | List of abbreviations (type-dependent)..... | 26 |
| 7.5 | Activating or deactivating the pushbutton lock..... | 28 |
| 7.6 | Resetting the device (factory setting)..... | 28 |
| 7.7 | Defaults..... | 28 |
| 7.8 | Pro level (advanced settings)..... | 33 |
| 7.9 | Other indicators and functions..... | 41 |

| | | |
|-----------|--|-----------|
| 8 | Troubleshooting..... | 43 |
| 8.1 | Possible errors during commissioning..... | 43 |
| 8.2 | Possible errors during operation..... | 43 |
| 9 | Maintenance..... | 44 |
| 9.1 | Maintenance..... | 44 |
| 9.2 | Cleaning the device..... | 44 |
| 10 | Decommissioning..... | 46 |
| 10.1 | Disassembly and disposal..... | 46 |
| 10.2 | Returning devices..... | 46 |
| 11 | Technical data..... | 47 |
| 11.1 | General data..... | 47 |
| 11.2 | Dimensional drawings..... | 49 |
| 12 | Accessories..... | 51 |
| 13 | Annex..... | 52 |
| 13.1 | EU declaration of conformity and certificates..... | 52 |
| 13.2 | Certification according to UL 60947-5-2..... | 52 |
| 13.3 | Licences..... | 52 |

1 About this document

1.1 Information on the operating instructions

These operating instructions provide important information on how to use devices from SICK AG.

Prerequisites for safe work are:

- Compliance with all safety notes and handling instructions supplied
- Compliance with local work safety regulations and general safety regulations for device applications

The operating instructions are intended to be used by qualified personnel and electrical specialists.



NOTE

Read these operating instructions carefully before starting any work on the device, in order to familiarize yourself with the device and its functions.

The instructions constitute an integral part of the product and are to be stored in the immediate vicinity of the device so they remain accessible to staff at all times. Should the device be passed on to a third party, these operating instructions should be handed over with it.

These operating instructions do not provide information on operating the machine in which the device is integrated. For information about this, refer to the operating instructions of the specific machine.

1.2 Scope

These operating instructions serve to incorporate the device into a customer system. Instructions are given by stages for all actions required.

These instructions apply to all listed device variants of the product.

Available device variants are listed on the online product page.

- ▶ www.sick.com/KTS_Prime
- ▶ www.sick.com/KTX_Prime

Commissioning is described using one particular device variant as an example.

Simplified device designation in the document

In the following, the sensor is referred to in simplified form as “KTS/KTX” or “device.”

1.3 Explanation of symbols

Warnings and important information in this document are labeled with symbols. The warnings are introduced by signal words that indicate the extent of the danger. These warnings must be observed at all times and care must be taken to avoid accidents, personal injury, and material damage.



DANGER

... indicates a situation of imminent danger, which will lead to a fatality or serious injuries if not prevented.

**WARNING**

... indicates a potentially dangerous situation, which may lead to a fatality or serious injuries if not prevented.

**CAUTION**

... indicates a potentially dangerous situation, which may lead to minor/slight injuries if not prevented.

**NOTICE**

... indicates a potentially harmful situation, which may lead to material damage if not prevented.

**NOTE**

... highlights useful tips and recommendations as well as information for efficient and trouble-free operation.

1.4 Further information

**NOTE**

All the documentation available for the device can be found on the online product page at:

- ▶ www.sick.com/KTS_Prime
- ▶ www.sick.com/KTX_Prime

The following information is available for download there:

- Type-specific online data sheets for device variants, containing technical data and dimensional drawings
 - EU declaration of conformity for the product family
 - Dimensional drawings and 3D CAD dimension models in various electronic formats
 - These operating instructions, available in English and German, and in other languages if necessary
 - Other publications related to the devices described here
 - Publications dealing with accessories
 - IO-Link driver files and IO-Link Technical Information v1.1
-

1.5 Customer service

If you require any technical information, our customer service department will be happy to help. To find your agency, see the final page of this document.

**NOTE**

Before calling, make a note of all type label data such as type code, serial number, etc., to ensure faster processing.

2 Safety information

2.1 Intended use

The KTS contrast sensor is an opto-electronic sensor for the optical, non-contact detection of contrasts.

A contrast sensor is designed for mounting and may only be operated according to its intended function. For this reason, it is not equipped with direct safety devices.

The system designer must provide measures to ensure the safety of persons and systems in accordance with the legal guidelines.

SICK AG assumes no liability for losses or damage arising from the use of the product, either directly or indirectly. This applies in particular to use of the product that does not conform to its intended purpose and is not described in this documentation.

2.2 Improper use

- The device does not constitute a safety-relevant device according to the EC Machinery Directive (2006/42/EC).
- The device must not be used in explosion-hazardous areas.
- Any other use that is not described as intended use is prohibited.
- Any use of accessories not specifically approved by SICK AG is at your own risk.

The device is not suitable for the following applications (this list is not exhaustive):

- As a safety device to protect persons, their hands, or other body parts
- Underwater
- In explosion-hazardous areas
- Outdoors, without additional protection



NOTICE

Danger due to improper use!

Any improper use can result in dangerous situations.

Therefore, observe the following information:

- ▶ The device should be used only in line with intended use specifications.
- ▶ All information in these operating instructions must be strictly complied with.

2.3 Limitation of liability

Applicable standards and regulations, the latest state of technological development, and our many years of knowledge and experience have all been taken into account when assembling the data and information contained in these operating instructions. The manufacturer accepts no liability for damage caused by:

- Failure to observe the operating instructions
- Improper use
- Use by untrained personnel
- Unauthorized conversions
- Technical modifications
- Use of unauthorized spare parts, wear and tear parts, and accessories

With special variants, where optional extras have been ordered, or owing to the latest technical changes, the actual scope of delivery may vary from the features and illustrations shown here.

2.4 Requirements for skilled persons and operating personnel



WARNING

Risk of injury due to insufficient training!

Improper handling of the device may result in considerable personal injury and material damage.

- All work must only ever be carried out by the stipulated persons.

The operating instructions state the following qualification requirements for the various areas of work:

- **Instructed personnel** have been briefed by the operating entity about the tasks assigned to them and about potential dangers arising from improper action.
- **Skilled personnel** have the specialist training, skills, and experience, as well as knowledge of the relevant regulations, to be able to perform tasks assigned to them and to detect and avoid any potential dangers independently.
- **Electricians** have the specialist training, skills, and experience, as well as knowledge of the relevant standards and provisions to be able to carry out work on electrical systems and to detect and avoid any potential dangers independently. In Germany, electricians must meet the specifications of the BGV A3 Work Safety Regulations (e.g., Master Electrician). Other relevant regulations applicable in other countries must be observed.

The following qualifications are required for various activities:

| Activities | Qualification |
|--|--|
| Mounting, maintenance | <ul style="list-style-type: none"> ■ Basic practical technical training ■ Knowledge of the current safety regulations in the workplace |
| Electrical installation, device replacement | <ul style="list-style-type: none"> ■ Practical electrical training ■ Knowledge of current electrical safety regulations ■ Knowledge of the operation and control of the devices in their particular application |
| Commissioning, configuration | <ul style="list-style-type: none"> ■ Basic knowledge of the design and setup of the described connections and interfaces ■ Basic knowledge of data transmission ■ Knowledge of the operation and control of the devices in their particular application |
| Operation of the devices in their particular application | <ul style="list-style-type: none"> ■ Knowledge of the operation and control of the devices in their particular application ■ Knowledge of the software and hardware environment in the application |

2.5 Hazard warnings and operational safety

Please observe the safety notes and the warnings listed here and in other chapters of these operating instructions to reduce the possibility of risks to health and avoid dangerous situations.

2.5.1 Eye safety



CAUTION

The device is equipped with LEDs. The device meets the criteria of risk group 1 according to IEC 62471:2006. No special measures are required (e.g., eye protection).

2.6 Repair

The product is a replacement device. The device is not intended to be repaired. Interference with or modifications to the device on the part of the customer will invalidate any warranty claims against SICK AG.

3 Product description

3.1 Product ID

3.1.1 Type label

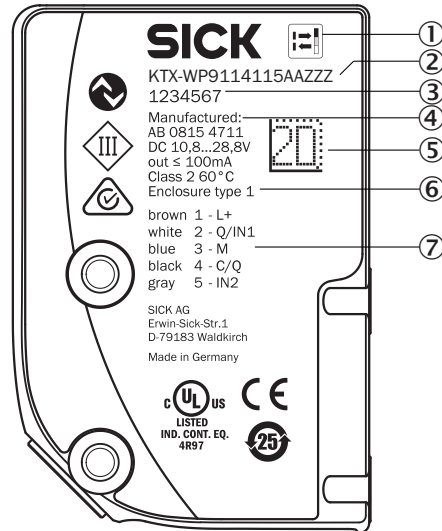

- ① Contrast sensor pictogram
- ② Device type number
- ③ Part number
- ④ Date of manufacture
- ⑤ 2D code
- ⑥ Electrical data and environmental data
- ⑦ Pin assignment

3.1.2 Type code

| | | | | | | | | | | | | | |
|----|---|---|---|---|---|---|---|---|---|----|----|----|----|
| 1 | 2 | - | 3 | 4 | 5 | 6 | 7 | 8 | 9 | 10 | 11 | 12 | 13 |
| KT | X | | W | B | 9 | 1 | 1 | 4 | 1 | 1 | 5 | A | A |

| Position | Meaning | |
|----------|--------------------------|--|
| 1 | Basic type | KT = contrast sensor |
| 2 | Form factor/housing size | S = small X = large |
| 3 | Light sender | W = RGB |
| 4 | Switching output | B = push/pull N = NPN P = PNP |
| 5 | Function | 9 = prime (1-point, 2-point, dynamic teach-in and automated switching threshold) |
| 6 | Light spot direction | 1 = longitudinal 2 = transverse 4 = round A = round, large |

| Position | Meaning | |
|----------|------------------|--|
| 7 | Sensing distance | 1 = sensing distance 13 mm 2 = sensing distance 25 mm 3 = sensing distance 40 mm 6 = sensing distance 70 mm 9 = sensing distance 150 mm |
| 8 | Filtering | 4 = no filter |
| 9 | Light emission | 1 = long side 2 = short side |
| 10 | Operation | 1 = long side 2 = short side |
| 11 | Connection type | 4 = M12, male connector 4-pin 5 = M12, male connector 5-pin |
| 12 | Communication | 2 = no communication A = IO-Link I = analog output (current) U = analog output (voltage) 9 = analog output (voltage) and analog input (voltage) |
| 13 | Device type | M = sample device S = special device F = private label A = automation function B = special device with automation function C = reserved Z = standard |

3.2 Product features and functions

3.2.1 Device view

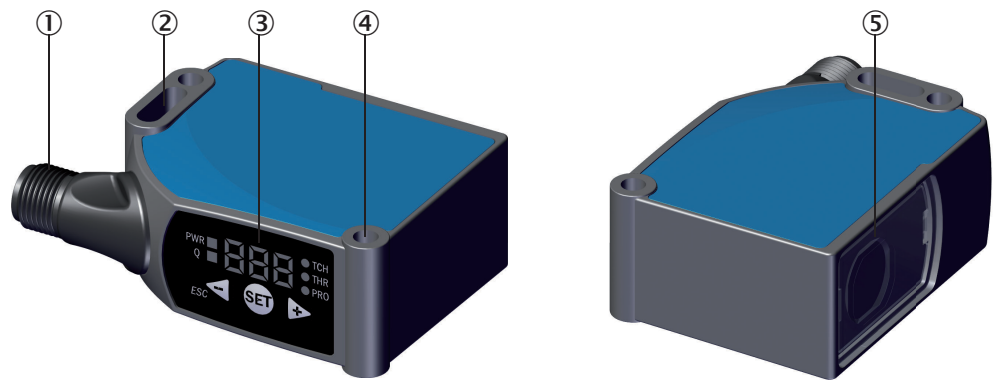

Figure 1: KTS Prime light emission long housing side

- ① Connection
- ② Mounting slot
- ③ Display and control panel
- ④ Fixing hole
- ⑤ Light emission

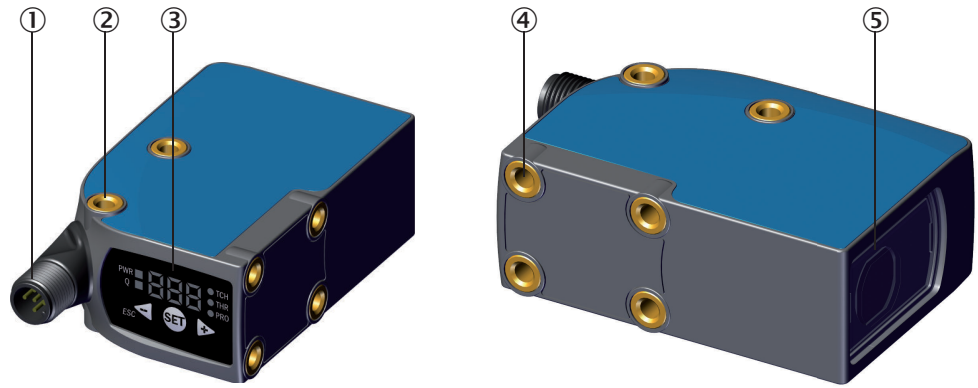

Figure 2: KTX Prime light emission short housing side

- ① Connection
- ② M5 mounting thread
- ③ Display and control panel
- ④ M5 mounting thread
- ⑤ Light emission

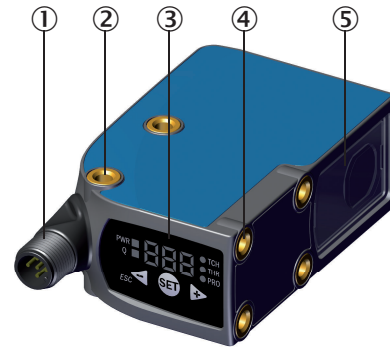

Figure 3: KTX Prime light emission long housing side

- ① Connection
- ② M5 mounting thread
- ③ Display and control panel
- ④ M5 mounting thread
- ⑤ Light emission

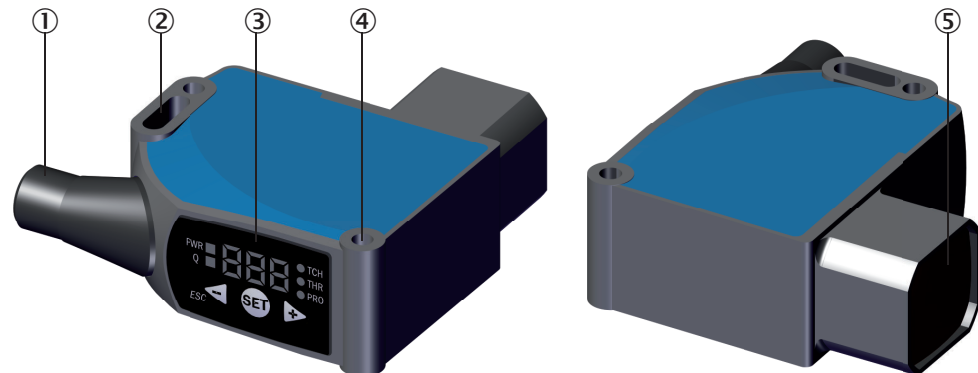

Figure 4: KTS Prime long sensing range light emission long housing side

- ① Connection
- ② Mounting slot
- ③ Display and control panel

- ④ Fixing hole
- ⑤ Light emission

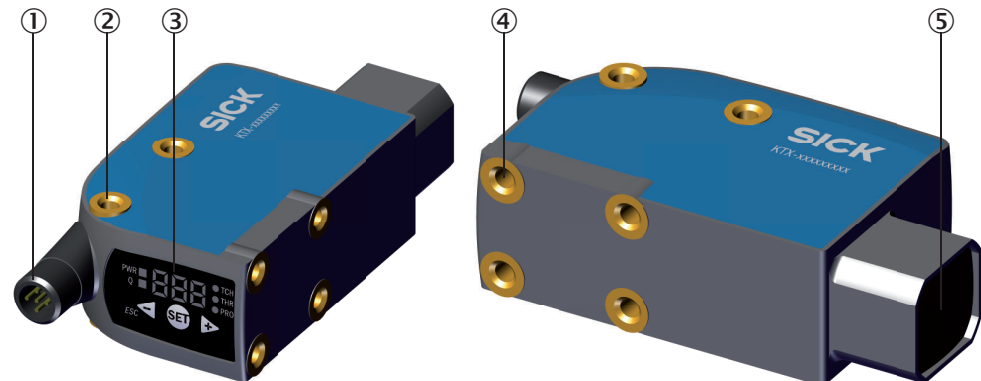

Figure 5: KTX Prime long sensing range light emission short housing side

- ① Connection
- ② M5 mounting thread
- ③ Display and control panel
- ④ M5 mounting thread
- ⑤ Light emission

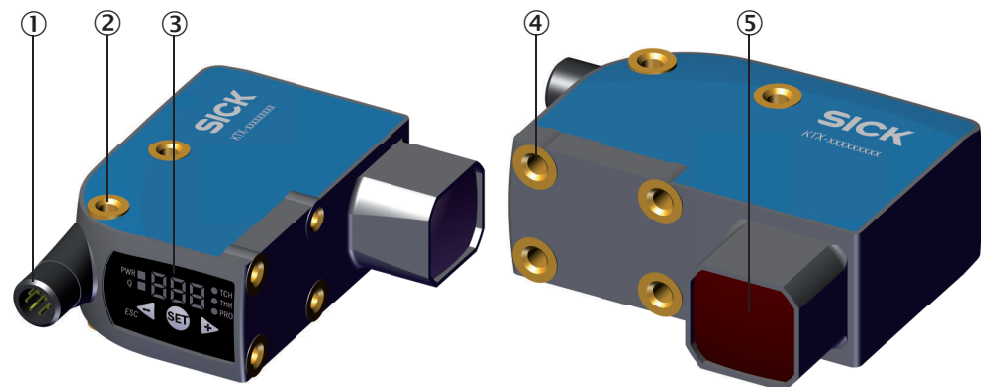

Figure 6: KTX Prime long sensing range light emission long housing side

- ① Connection
- ② M5 mounting thread
- ③ Display and control panel
- ④ M5 mounting thread
- ⑤ Light emission

3.2.2 Product characteristics

Contrast sensors are primarily used in packaging or printing machines for detecting marks.

However, they can also be used in any application based on making a distinction between contrasts.

KTS/KTX contrast sensors detect even the smallest contrasts at the highest speeds, such as print marks on foils or packaging. They detect minute grayscale variations between the mark and the background on matte, shiny, or transparent surfaces. Device types are available with different methods of contrast resolution and different teach-in variants for a wide range of requirements.

Features

- TwinEye technology® for increased depth of field and sensing distance tolerance
- 50 kHz switching frequency
- Large dynamic range means reliable detection of contrasts on glossy materials
- 7-segment display
- Color mode
- Mounting feedback
- IO-Link and Smart Tasks
- Flexible sensor setting thanks to various sensor parameters

Fields of application

- Applications in which contrast or color is a basic distinguishing feature
- Print mark detection for controlling the cutting process
- Print control in the print and paper industry
- Positioning of tubes when filling
- Label alignment on bottles
- Monitoring of wafer surfaces
- Roll end monitoring
- Color control in yarn or line production

4 Mounting

4.1 Scope of delivery

- Contrast sensor in the version ordered
- Quickstart
- Safety notes

4.2 Mounting requirements

- Typical space requirement for the device, see type-specific dimensional drawing, see ["Technical data", page 47](#).
- Comply with technical data, such as the permitted ambient conditions for operation of the device (e.g., temperature range, EMC interference emissions, ground potential).
- To prevent condensation, avoid exposing the device to rapid changes in temperature.
- Protect the device from direct sunlight.
- The device must only be mounted using the pairs of mounting threads/fixing holes provided for this purpose.
- Shock and vibration-free mounting.

4.3 Mounting the device

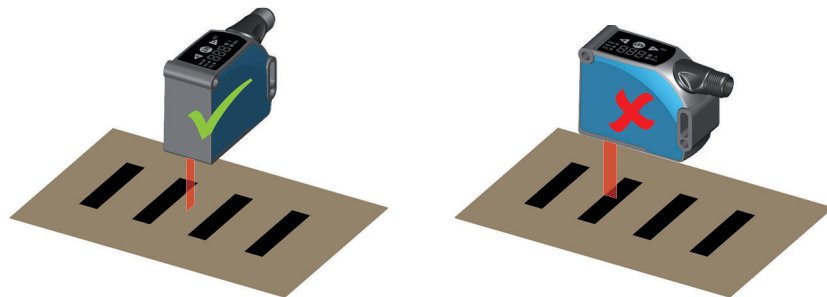

Figure 7: KTS Prime

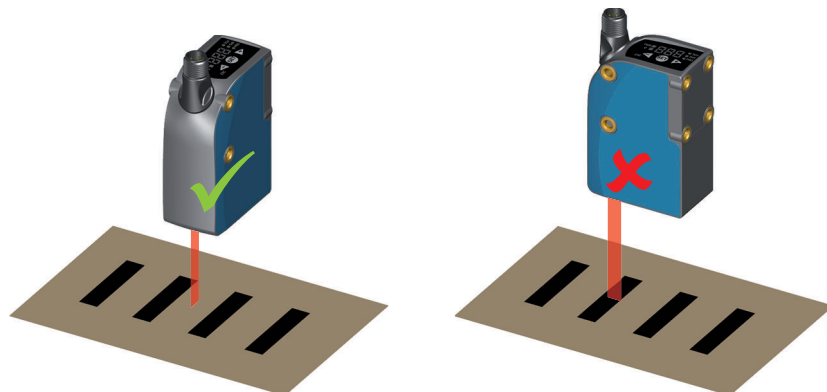

Figure 8: KTX Prime light emission short housing side

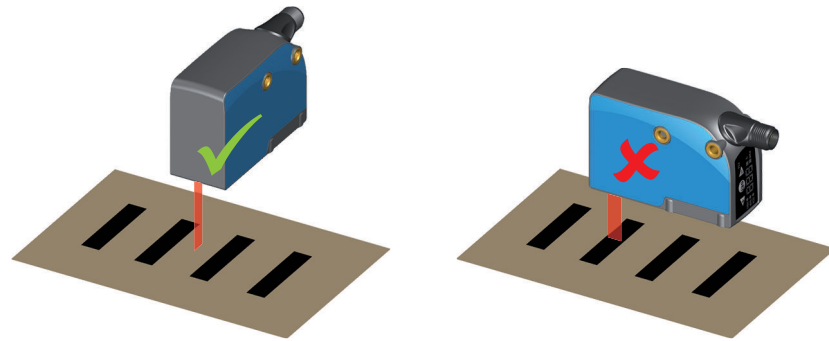

Figure 9: KTX Prime light emission long housing side

1. The adjustment quality is automatically shown in the display as mounting feedback during the first device initialization. To do so, the device must be brought within the nominal sensing distance manually, ideally on light material (see data sheet). Pay attention to the figure during alignment. After adjustment, quit the process with any pushbutton.
2. Install the device via the fixing hole so that the light spot enters the mark longitudinally and the test object has the least possible vertical and horizontal movement. Note the sensing distance while doing so.
3. Compensate for the vertical and horizontal movement of the test object by marks of suitable lengths.
4. Ensure that any device movement does not affect the sensing distance.

Mounting feedback



NOTE

Assembly feedback (AdJ) is only available for standard variants with a sensing distance of 13 mm and 25 mm.

Table 1: Mounting feedback indicator

| | |
|--|--|
| | Sensing distance set too close or too far away. |
| | Sensing distance set within the detection range, but not at the optimum level. |
| | Nominal sensing distance set. |

To secure a stable detection when having high gloss material a tilt angle of 10°-15° might be necessary.

5 Electrical installation

5.1 Notes on the electrical installation



NOTICE

Device damage due to incorrect supply voltage!

An incorrect supply voltage may result in damage to the device.

- Only operate the device with safety/protective extra-low voltage (SELV/PELV).
- The sensor is a device of protection class III.



NOTICE

Device damage due to incorrect supply voltage!

An incorrect supply voltage may result in damage to the device.

- Only operate the device with an LPS (limited power source) in accordance with IEC 60950-1 or an NEC Class 2 power supply unit.



NOTICE

Device damage or unpredictable operation due to working with live parts!

Working with live parts may result in unpredictable operation.

- Only carry out wiring work when the power is off.
- Only connect and disconnect electrical connections when the power is off.

- **The electrical installation must only be performed by electrically qualified personnel.**
- **Standard safety requirements must be met when working on electrical systems!**
- Only switch on the supply voltage for the device when the connection tasks have been completed and the wiring has been thoroughly checked.
- When using extension cables with open ends, ensure that bare wire ends do not come into contact with each other (risk of short-circuit when supply voltage is switched on!). Wires must be appropriately insulated from each other.
- Wire cross-sections in the supply cable from the user's power system must be selected in accordance with the applicable standards.
- Only operate the device with an LPS (limited power source) in accordance with IEC 60950-1 or an NEC Class 2 power supply unit.
- All circuits connected to the device must be designed as SELV/PELV circuits.
- Operation in short-circuit protected network at max. 8 A.



NOTE

Layout of data cables

- Use screened data cables with twisted-pair wires.
- Implement the screening design correctly and completely.
- To avoid interference, e.g., from switching power supplies, motors, clocked drives, and contactors, always use cables and layouts that are suitable for EMC.
- Do not lay cables over long distances in parallel with voltage supply cables and motor cables in cable channels.

The IP enclosure rating for the device is only achieved under the following conditions:

- The cables plugged into the connections are screwed tight.

If these instructions are not complied with, the IP enclosure rating for the device is not guaranteed!

5.2 Note on the swivel connector



NOTICE

Damage to the connector unit from over-tightening!

The connector unit on the device has two opposite end positions.

- Do not rotate the connector unit from either of the two end positions by more than 180°.

5.3 Pin assignment of the connections



NOTE

The function of pin 2 depends on the teach-in variant, if the pin 2 configuration is set to AUTO (factory setting).



NOTE

Pin 5 can only be assigned with L/D if L/D is set to AUTO in the defaults.

Overview of pin assignment

Table 2: M12 male connector, 5-pin

| | 2-P | 1-P | dyn. | AUTO |
|---|-----|-----|------|------|
| 1 | L+ | L+ | L+ | L+ |
| 2 | Q | Q | Q | Q |
| 3 | M | M | M | M |
| 4 | Q/C | Q/C | Q/C | Q/C |
| 5 | ET | ET | ET | L/D |

Legend

L+ = supply voltage

M = ground

Q = switching output

Q/C = switching output and communication

ET = external teach-in

L/D = light/dark

5.4 Connecting the supply voltage



NOTICE

Risk of damage to the device!

The device can become damaged if it is connected to a voltage supply that is already switched on.

- Only connect the device when the supply cable is de-energized.

The device must be connected to a power supply unit with the following properties:

- Supply voltage DC 10.8 V – 28.8 V (SELV/PELV as per currently valid standards)
- Electricity source with at least 3 W power

To ensure protection against short-circuits/overload in the customer’s supply cables, the wire cross-sections used must be appropriately selected and protected.

5.5 Wiring the interfaces

5.5.1 Wiring the digital inputs

The digital inputs can be used to start a teach-in procedure or to select a device operating mode.

The number of digital inputs available at the connections will vary, depending on the device, see ["Pin assignment of the connections"](#), page 18.

Voltage level at the input starts the corresponding function of the device.

Electrical values

LOW: $0\text{ V} \leq U \leq 2\text{ V}$

HIGH: $10\text{ V} \leq U \leq U_V$

Input, teach-in (ET)

PNP and push/pull: Teach = HIGH; Run = LOW

NPN: Teach = LOW; Run = HIGH

Input, blanking input (AT)

PNP and push/pull: Blanked = HIGH; Free = LOW

NPN: Blanked = LOW; Free = HIGH

Input, light/dark (L/D)

PNP and push/pull: Light switching = HIGH; Dark switching = LOW

NPN: Light switching = LOW; Dark switching = HIGH

Input, system sensitivity (F/C)

PNP and push/pull: Coarse = HIGH; Fine = LOW

NPN: Coarse = LOW; Fine = HIGH

5.5.2 Wiring the digital outputs

The number of digital outputs available at the connections will vary, depending on the device, see ["Pin assignment of the connections"](#), page 18. If the allocated event occurs in the detection process, then the corresponding digital output is live.

In each case, the digital outputs are short-circuit protected and overcurrent protected.

Switching behavior: PNP or NPN or push/pull

Electrical values

The sum current (100 mA) for all digital outputs is identical.

PNP HIGH: $U_V - 3\text{ V}$; **LOW:** 0 V

NPN HIGH: U_V ; **LOW:** $\leq 3\text{ V}$

Push/pull HIGH: $U_V - 3\text{ V}$; **LOW:** $\leq 3\text{ V}$

In the case of a push/pull sensor, the signal must be inverted in the control system in order to obtain the same result as a sensor with NPN switching behavior.

Table 3: Push-Pull

| | | |
|------------------------------|-------------------------------|-------------------------------|
| | <p>PWR ■ Q ■</p> | <p>PWR ■ Q □</p> |
| Q push-pull (≤ 100 mA) | <p>+ (L+) Q - (M)</p> | <p>+ (L+) Q - (M)</p> |

Table 4: PNP

| | | |
|------------------------|-------------------------------|-------------------------------|
| | <p>PWR ■ Q ■</p> | <p>PWR ■ Q □</p> |
| Q PNP (≤ 100 mA) | <p>+ (L+) Q - (M)</p> | <p>+ (L+) Q - (M)</p> |

Table 5: NPN

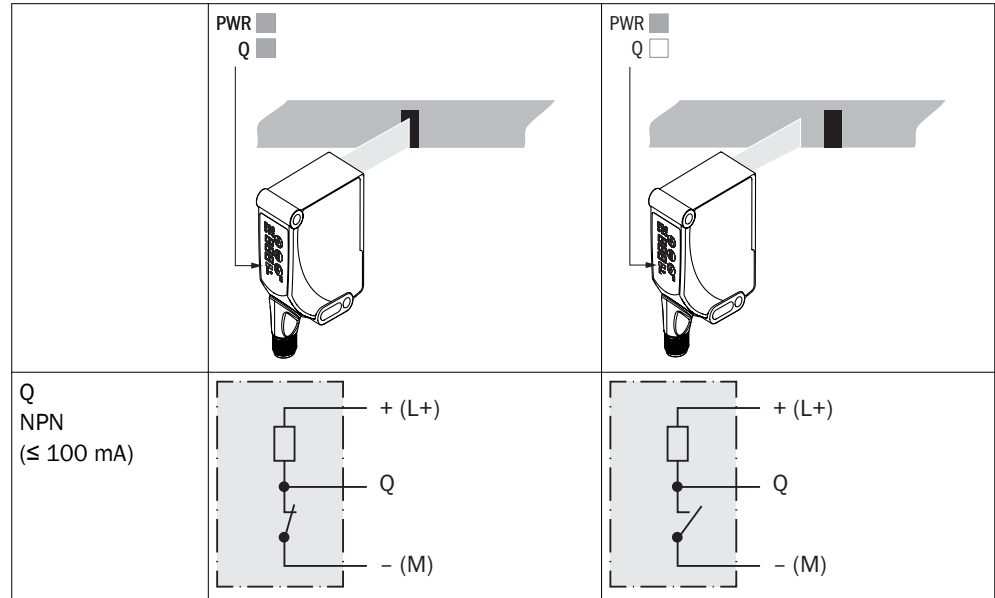



6 Commissioning

6.1 Simplified illustration

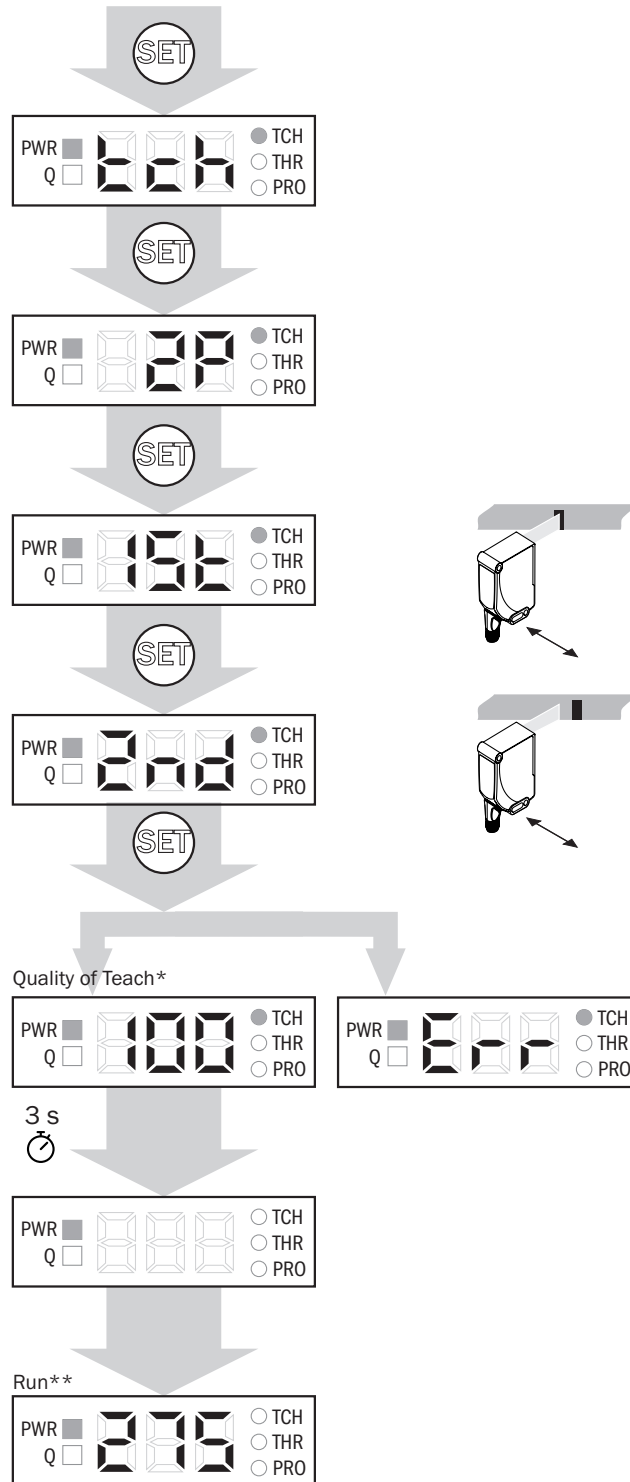
Carry out the following steps based on the example of the 2P teach:



Quality of TeachTable 6: Quality of Teach indicator*

| Value | Quality |
|----------|---|
| 61 - 100 |  |
| 31 - 60 |  |
| 1 - 30 |  |

****Run = indicates the live measured value***Table 7: Quality of Run indicator*

| Value | Remission value |
|-------|---|
| 0 | No remission |
| 400 | White |
| 999 | Maximum remission, with glossy material |

7 Operation

7.1 Operating elements

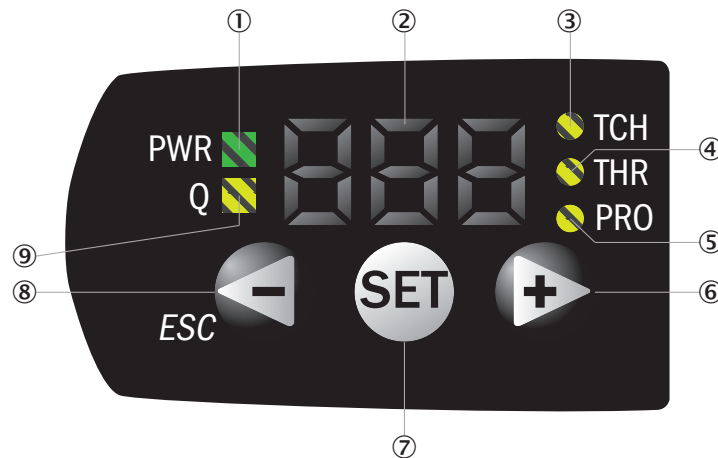

Figure 10: ALD display operating elements

Table 8: Operating elements legend

| Number | Description | Function |
|--------|-----------------|---|
| 1 | PWR | Illuminates when the voltage supply is connected. Flashes when IO-Link communication is active. |
| 2 | Segment display | Shows menu item, values, or qualities. |
| 3 | TCH | Illuminates when the “teach-in” menu is selected. |
| 4 | THR | Illuminates when the “threshold” menu is selected. |
| 5 | PRO | Illuminates when the “advanced settings” menu is selected. |
| 6 | Plus | Scrolls through menu items or increases values. |
| 7 | SET | Opens the menu, confirms entries, or switches to lower-level menus. |
| 8 | Minus/ESC | Switches to the previous menu item, decreases values, or cancels the current operation (press for > 3 s). |
| 9 | Q | Illuminates when there is a switching event. |

7.2 Navigation tree, general

To leave the current menu level, press and hold the minus pushbutton for > 3 seconds.



NOTE

Assembly feedback (Adj) is only available for standard variants with a sensing distance of 13 mm and 25 mm.

7.3 Navigation tree, pro level (advanced settings)

To leave the current menu level, press and hold the minus pushbutton for > 3 seconds.

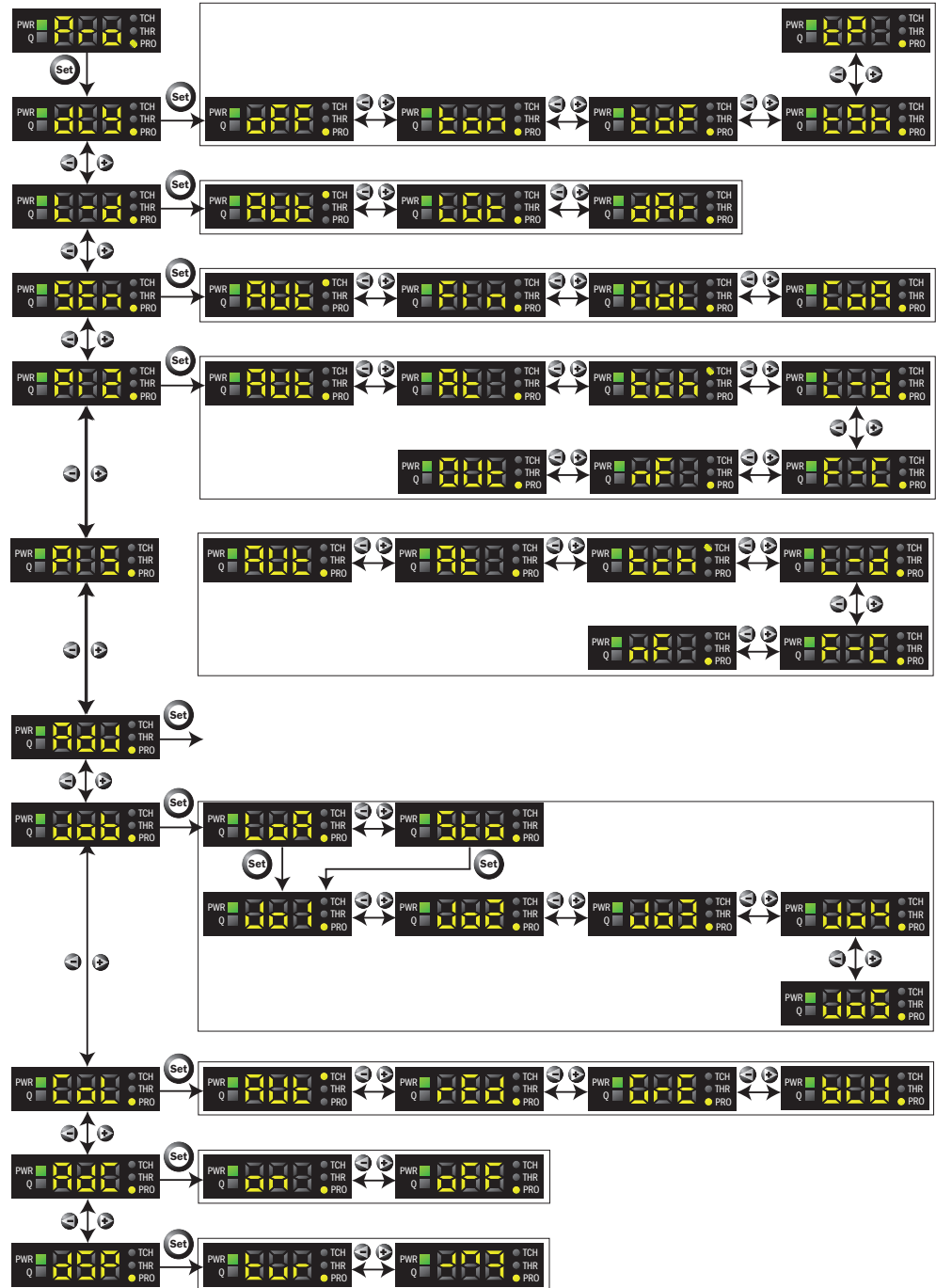

NOTE

Assembly feedback (AdJ) is only available for standard variants with a sensing distance of 13 mm and 25 mm.

7.4 List of abbreviations (type-dependent)

Table 9: List of abbreviations

| Display | Meaning |
|---------|-------------------|
| 1P | 1-point teach-in |
| 1St | First teach point |

| Display | Meaning |
|---------|-------------------------------|
| 2nd | Second teach point |
| 2P | 2-point teach-in |
| A90 | Time stamp |
| AdC | Contamination tracking |
| AdJ | Alignment |
| AFc | Automatic function |
| At | Blanking |
| AUt | Automated |
| blU | Blue |
| bSY | Busy |
| CoL | Color |
| CoA | Coarse |
| dAr | Dark |
| dIY | Delay |
| dSP | Display switch |
| dYn | Dynamic teach-in |
| Err | Error |
| F-C | Fine/coarse |
| FIn | Fine |
| GrE | Green |
| Job | Parameter sets |
| Jo1 | Parameter set 1 |
| Jo2 | Parameter set 2 |
| Jo3 | Parameter set 3 |
| Jo4 | Parameter set 4 |
| Jo5 | Parameter set 5 |
| L-d | Light/dark |
| LGt | Light |
| LoA | Load |
| LoC | Locked |
| Mdl | Middle |
| nF | No function |
| oFF | Off |
| OUT | Output |
| PI1 | Pin 1 configuration |
| PI2 | Pin 2 configuration |
| PI5 | Pin 5 configuration |
| Pro | Pro level (advanced settings) |
| rEd | Red |
| rES | Reset |
| Sen | Sensitivity |
| Sto | Store |
| tch | Teach-in |

| Display | Meaning |
|---------|---|
| thr | Threshold |
| toF | Timer – OFF delay |
| ton | Timer – ON delay |
| tP | Pulse generator |
| tSh | Switch-on/switch-off delay (on/off delay) |
| tur | Turn (display) |

7.5 Activating or deactivating the pushbutton lock

1. Press and hold the plus pushbutton for 10 seconds.



2. The pushbutton lock is active or deactivated.

7.6 Resetting the device (factory setting)

1. Press and hold the plus and minus pushbuttons for 10 s.



2. The set parameters are reset to the factory settings.

7.7 Defaults

The defaults specify the parameters required for operating the device. It is often the case that only these parameters need to be set in order to use the device.

7.7.1 Teach-in

Several teach-in processes are available for configuring the device:

- 1-point teach-in/color mode
- 2-point teach-in
- Dynamic teach-in
- Auto mode

7.7.1.1 2-point teach-in (factory setting)

Suitable for manual positioning of the object to be detected, e.g., mark and background.

1. Press the SET pushbutton.
2. Use the plus or minus pushbutton to select teach-in.



3. Press the SET pushbutton.
4. Use the plus or minus pushbutton to select 2P.



5. Press the SET pushbutton.
6. Position the mark under the light spot.



7. Press the SET pushbutton.
8. Position the background under the light spot.



9. Press the SET pushbutton. The Quality of Teach is displayed.



Quality of Teach

Table 10: Quality of Teach indicator

| Indication | Meaning |
|------------|---------------------------------|
| 61 - 100 | Excellent detection reliability |
| 31 - 60 | Good detection reliability |
| 1 - 30 | Poor detection reliability |

7.7.1.2 1-point teach-in/color mode

Suitable for teaching in color properties.

1. Press the SET pushbutton.
2. Use the plus or minus pushbutton to select teach-in.



3. Press the SET pushbutton.
4. Use the plus or minus pushbutton to select 1P.



5. Press the SET pushbutton.



6. Position the object to be detected under the light spot.
7. Press the SET pushbutton. The Quality of Teach is displayed.



7.7.1.3 Dynamic teach-in



NOTE

If there are interference impulses in the background, the dynamic teach enables a stable switching signal. The system sensitivity must be switched to fine or middle in order to blank interference impulses.

In the coarse factory setting, the switching threshold is set at 50% between the mark and background.

Suitable for teaching in moving objects.

Dark switching (coarse)

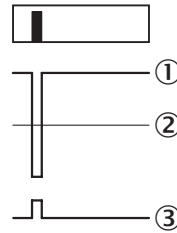

Dark switching (fine / middle)

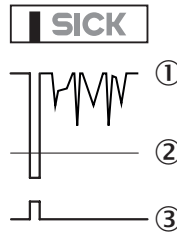

- ① Internal received signal
- ② Switching threshold
- ③ Output Q

1. Press the SET pushbutton.
2. Use the plus or minus pushbutton to select tch.



3. Press the SET pushbutton.
4. Use the plus or minus pushbutton to select dYn.



5. Press the SET pushbutton.
6. Position the mark or background under the light spot.
The display lights up during repeat length detection. One repeat length is sufficient for web lengths of between 0 m/s and 2 m/s. At least 2 or 3 repeat lengths are recommended.



7. Press the SET pushbutton to quit the teach-in operation. The Quality of Teach is displayed.



7.7.1.4 Auto mode

In Auto mode, the device automatically switches when contrast variations occur. In so doing, the device calculates and dynamically adapts the switching threshold, depending on the sensitivity adjustment. A teach-in is not required. In Auto mode, the external teach function is deactivated.

1. Press the SET pushbutton.
2. Use the plus or minus pushbutton to select tch.



3. Press the SET pushbutton.
4. Use the plus or minus pushbutton to select AUT.



5. Press the SET pushbutton.



7.7.2 External teach-in

7.7.2.1 2-point teach-in

Suitable for manual positioning of the object to be detected, e.g., mark and background.

1. Position the mark under the light spot.
2. Activate teach-in via the control cable (ET).
3. Position the background under the light spot.
4. Activate teach-in via the control cable (ET).
5. The teach-in process is complete.

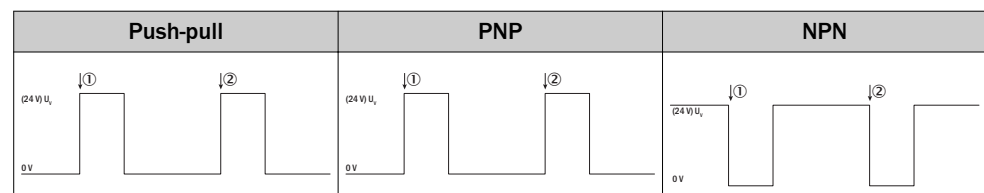

- ① 1. Teach point
② 2. Teach point

7.7.2.2 Dynamic teach-in

Suitable for teaching in moving objects.

1. Activate teach-in via the control cable (ET) and hold.
2. Position the background or the mark under the light spot.
3. One repeat length is sufficient for a web length between 0 m/s and 2 m/s. At least 2 - 3 repeat lengths are recommended.
4. Deactivate teach-in via the control cable (ET).
5. The teach-in process is complete.

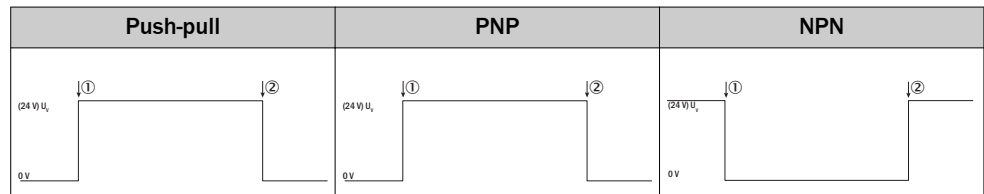

- ① Start teach-in
- ② Stop teach-in

7.7.2.3 1-point teach-in

Suitable for teaching in color properties.

1. Position the object to be detected under the light spot.
2. Activate teach-in via the control cable (ET).
3. The teach-in process is complete.

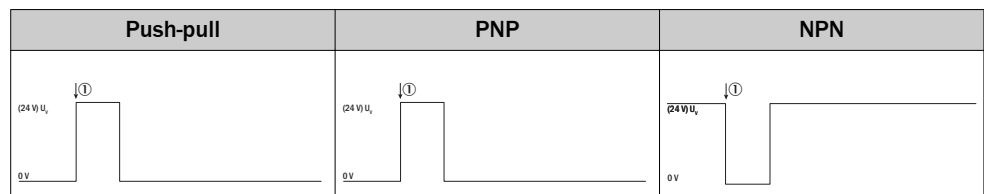

- ① Teach point

7.7.3 Adjusting the switching threshold

During teach-in, the remission value of the switching threshold displayed is automatically set between the mark and background and corresponds to a switching threshold of 50%.

If the switching events do not correspond to the expected results, the switching threshold can be adjusted independently of the teach-in process.

1. Press the SET pushbutton.
Use the plus or minus pushbutton to select thr.



2. Press the SET pushbutton.



3. Use the plus or minus pushbutton to adjust the switching threshold.



4. Press the SET pushbutton to confirm the switching threshold.



NOTE

If the switching thresholds are undershot (light switching) or overshot (dark switching), the Q LED goes out. The value display flashes if the switching threshold is undershot.



NOTE

If the switching threshold has been manually adjusted, the AdC function is deactivated.

**NOTE**

After 1-point teach-in, it is not possible to adjust the switching threshold (thr = off).

7.8 Pro level (advanced settings)

You can use the advanced settings to adapt the device to the particular application conditions or to configure additional values and functions.

7.8.1 Adjusting the switching logic (light/dark)

The “AUTO” switching logic is preset (factory setting). Light or dark switching is detected automatically by the sensor.

Dark switching

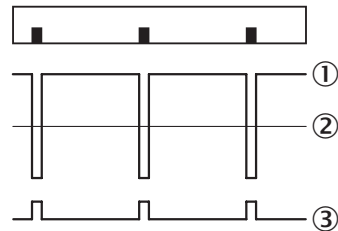

Light switching

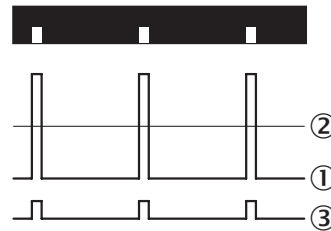

- ① Internal received signal
- ② Switching threshold
- ③ Output Q

1. Press the SET pushbutton.
2. Use the plus or minus pushbutton to select Pro.



3. Press the SET pushbutton.
4. Use the plus or minus pushbutton to select L-D.



5. Press the SET pushbutton.
6. Use the plus or minus pushbutton to select the required setting.



Automated (factory setting)



Light switching

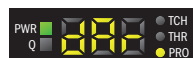

Dark switching

7. Press the SET pushbutton.

7.8.2 Setting the switch-on and switch-off delay

1. Press the SET pushbutton.
2. Use the plus or minus pushbutton to select Pro and press the SET pushbutton.



3. Press the SET pushbutton.
4. Use the plus or minus pushbutton to select dLY.



5. Press the SET pushbutton.

Setting the switch-on delay

1. Use the plus or minus pushbutton to select ton.



2. Press the SET pushbutton.
3. Use the plus or minus pushbutton to select the switch-on delay in milliseconds in the range 1 - 500.
Press and hold the pushbutton to increase or reduce the values rapidly.



4. Press the SET pushbutton.

Setting the switch-off delay

1. Use the plus or minus pushbutton to select toF.



2. Press the SET pushbutton.
3. Use the plus or minus pushbutton to select the switch-off delay in milliseconds in the range 1 - 500.



4. Press the SET pushbutton.

Setting the switch-on and switch-off delay (shift)

1. Use the plus or minus pushbutton to select tSh.



2. Press the SET pushbutton.
3. Use the plus or minus pushbutton to select the switch-on delay in milliseconds in the range 1 – 500.



4. Press the SET pushbutton.

Adjusting the pulse generator

1. Use the plus or minus pushbutton to select tP.



2. Press the SET pushbutton.
3. Use the plus or minus pushbutton to select the duration of the pulse in milliseconds in the range 1 – 500.



4. Press the SET pushbutton.

7.8.3 Adjusting the switching sensitivity

The contrast differences that have been taught are stored with a tolerance range. The magnitude of the tolerance range can be set to one of four values (reliable, standard, sensitive, and automated).

Measurement is more reliable when using a greater tolerance if the contrast differences of the object vary. The sensor signals a teaching failure (Q LED flashes and “Err” appears on the display) when tolerance ranges overlap after changing to a coarser sensitivity.

1. Press the SET pushbutton.
2. Use the plus or minus pushbutton to select Pro.



3. Press the SET pushbutton.
4. Use the plus or minus pushbutton to select SEN.



5. Press the SET pushbutton.
6. Use the plus or minus pushbutton to select the required setting.



7. Press the SET pushbutton.

7.8.4 PIN 2 configuration



NOTE

L / D via line is only evaluated during teach-in via line.

1. Press the SET pushbutton.
2. Use the plus or minus pushbutton to select Pro.



3. Press the SET pushbutton.
4. Use the plus or minus pushbutton to select PI2.



5. Press the SET pushbutton.
6. Use the plus or minus pushbutton to select the required setting.

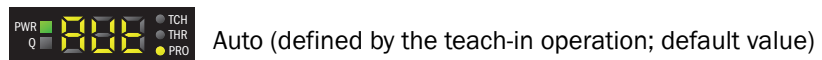

7. Press the SET pushbutton.

**NOTE**

If PIN 2 is assigned with tch (external teach-in), the teach-in variant can be defined too (2-point, dynamic, or 1-point).

**NOTE**

If you want to use PIN 2 as an input with function L-D or F-C, function L/D or SEn must be set to AUt in the default.

7.8.5 PIN 5 configuration**NOTE**

L / D via line is only evaluated during teach-in via line.

1. Press the SET pushbutton.
2. Use the plus or minus pushbutton to select PRO.



3. Press the SET pushbutton.
4. Use the plus or minus pushbutton to select PI5.



5. Press the SET pushbutton.
6. Use the plus or minus pushbutton to select the required setting.



Auto (defined by the teach-in operation; default value)



Blanking



External teach-in



Switching logic



System sensitivity



No function

7. Press the SET pushbutton.

**NOTE**

If PIN 5 is assigned with tch (external teach-in), the teach-in variant can be defined too (2-point, dynamic, or 1-point).

If you want to use PIN 5 as an input with function L-D or F-C, function L/D or SEn must be set to AUt in the default.

7.8.6 Using mounting feedback



NOTE

Assembly feedback (Adj) is only available for standard variants with a sensing distance of 13 mm and 25 mm.

1. Press the SET pushbutton.
2. Use the plus or minus pushbutton to select Pro.



3. Press the SET pushbutton.
4. Use the plus or minus pushbutton to select Adj.



5. Press the SET pushbutton.
6. Adjust the device height manually.



7. Press the SET pushbutton when the device is positioned within the nominal sensing distance.

Table 11: Mounting feedback indicator

| Indications | Meaning |
|-------------|--|
| | Sensing distance set too close or too far away |
| | Sensing distance set to moderate |
| | Nominal sensing distance |

7.8.7 Storing or loading a parameter set (job)

Stored parameter sets (jobs) make it possible to permanently save and flexibly manage specific application parameters (e.g., teach process, sender color, etc.) in the device for certain marks or applications.

1. Press the SET pushbutton.
2. Use the plus or minus pushbutton to select Pro.



3. Press the SET pushbutton.
4. Use the plus or minus pushbutton to select Job.



5. Press the SET pushbutton.
6. Use the plus or minus pushbutton to choose between Sto (store) and LoA (load).



7. Press the SET pushbutton.



8. Use the plus or minus pushbutton to select one of the 5 memory locations (in this case, Job3).



9. Press the SET pushbutton.

7.8.8 Adjusting the color fixation



NOTE

During 1P teach (color mode), this function is deactivated.

You can use the color fixation to restrict the light source to one particular sender color (red, green, or blue). In the factory setting, the sender color is set to automated.

1. Press the SET pushbutton.
2. Use the plus or minus pushbutton to select Pro.



3. Press the SET pushbutton.
4. Use the plus or minus pushbutton to select Col.



5. Press the SET pushbutton.
6. Use the plus or minus pushbutton to select Sender color.





7. Press the SET pushbutton.

7.8.9 Setting contamination tracking

In difficult application conditions (e.g., due to dust deposits or varying print quality), contamination tracking can be used to optimize the stability of detection. This is activated at the factory.



NOTE

If the switching threshold has been manually adjusted, the AdC function is deactivated.



NOTE

With the high precision variant, the function is deactivated at the factory.

1. Press the SET pushbutton.
2. Use the plus or minus pushbutton to select Pro.



3. Press the SET pushbutton.
4. Use the plus or minus pushbutton to select AdC.



5. Press the SET pushbutton.
6. Use the plus or minus pushbutton to choose between activated and deactivated contamination tracking.

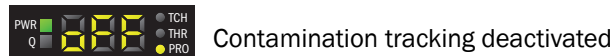
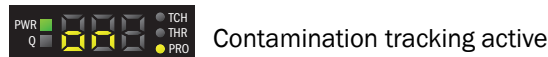

7. Press the SET pushbutton.

7.8.10 Rotating the display

If the installation position of the device makes it difficult to read from the segment display, the display can be rotated 180°.

1. Press the SET pushbutton.
2. Use the plus or minus pushbutton to select Pro.



3. Press the SET pushbutton.
4. Use the plus or minus pushbutton to select dSP.



5. Press the SET pushbutton.



6. Use the plus or minus pushbutton to select the direction in which the segment display points.



7. Press the SET pushbutton.

7.9 Other indicators and functions

Incorrect teach-in



In the event of a teach-in failure, Err appears on the display and the Q LED and TCH LED flash.

Control panel locked



If the device is undergoing an internal process (e.g., reading or storing parameter sets or teaching in via IO-Link), the control panel is locked and the device shows "bSY" on the segment display.

Short-circuit and overcurrent detection



In the event of a short-circuit, Err appears on the display and the Q LED flashes.

Live measured value (run mode)

In run mode, the device displays the remission value currently being measured as a digit.



Table 12: Remission value indicator

| Value | Remission value |
|-------|---|
| 0 | No remission |
| 400 | White |
| 999 | Maximum remission, with glossy material |

Display standby



NOTE

Control panel standby mode is not activated when a teach-in process is ongoing or while an error message is displayed.

If no settings are made on the device for 5 minutes, standby mode is activated to save electricity. Any settings made which have not been confirmed are not adopted.

To quit standby mode, one of the operating keys must be pushed.

8 Troubleshooting

8.1 Possible errors during commissioning

Table 13: Troubleshooting during commissioning

| Display, error situation | Cause | Measure |
|---|--|---|
| <ul style="list-style-type: none"> • “Err” flashes • Q LED (yellow) flashes | <ul style="list-style-type: none"> • Short-circuit message/ overcurrent message • Sensor is not connected properly | <ul style="list-style-type: none"> • Disconnect sensor from the power network • Check pin assignment • Reconnect sensor • Check the current at the switching output |
| No change to the segment display in Mounting feedback mode | <ul style="list-style-type: none"> • Distance between the sensor and the background is too large or too small • Light emission (optics) is dirty | <ul style="list-style-type: none"> • Clean sensor • Check the application conditions • Restart adjustment process |
| After the teach process <ul style="list-style-type: none"> • “Err” flashes • Q LED (yellow) and TCH LED (yellow) flash • No signal change at the switching output for object detection | Programmed contrast or contrast difference is not sufficient for stable contrast detection. | <ul style="list-style-type: none"> • Readjust sensor • Clean sensor • Check the application conditions • Restart teach process • Increase contrast difference |

8.2 Possible errors during operation

Table 14: Troubleshooting during operation

| Display, error situation | Cause | Measure |
|------------------------------|--|--|
| Busy | Sensor is undergoing an internal process. | Wait until the process has finished. |
| No switching output any more | <ul style="list-style-type: none"> • Distance or angle to material not consistent • Light emission (optics) is dirty • Manual switching threshold set incorrectly | <ul style="list-style-type: none"> • Clean sensor • Readjust sensor • Check parameter settings • Perform teach process again |

9 Maintenance

9.1 Maintenance

During operation, the device works maintenance-free.

Depending on the assignment location, the following preventive maintenance tasks may be required for the device at regular intervals:

Table 15: Maintenance schedule

| Maintenance work | Interval | Implementation |
|---|---|----------------|
| Clean housing and front screen | Cleaning interval depends on ambient conditions and climate | Specialist |
| Check screw connections and plug connectors | Every 6 months | Specialist |

9.2 Cleaning the device

At regular intervals (e.g., weekly), check the light emission window and the housing of the device for dirt. This is especially relevant in harsh operating environments (dust, abrasion, damp, fingerprints, etc.). The lens of the light emission window must be kept clean and dry during operation.



NOTICE

Device damage due to improper cleaning!

Improper cleaning may result in device damage.

- Only use suitable cleaning agents.
- Never use sharp objects for cleaning.

Cleaning the light emission window



NOTICE

Damage to the light emission window!

Reduced reading performance due to scratches or streaks on the light emission window!

- ▶ Clean the light emission window only when wet.
- ▶ Use a mild cleaning agent that does not contain powder additives. Do not use aggressive cleaning agents, such as acetone, etc.
- ▶ Avoid any movements that could cause scratches or abrasions on the light emission window.
- ▶ Only use cleaning agents suitable for the lens material.



NOTE

Static charge may cause dust particles to stick to the light emission window. This effect can be avoided by using an anti-static glass cleaner in combination with the SICK lens cloth (can be obtained from www.sick.com).



NOTE

If the light emission window is scratched or damaged (cracked or broken), the device must be replaced. Contact SICK Service to arrange this.

Cleaning the housing

In order to ensure that the heat produced by the internal power loss is adequately dissipated, the housing surface must be kept clean.

10 Decommissioning

10.1 Disassembly and disposal

Disassembling the device

1. Switch off the supply voltage to the device.
2. Detach all connecting cables from the device.
3. If the device is being replaced, mark its position and alignment on the bracket or surroundings.
4. Detach the device from the bracket.

Disposing of the device

Any device which can no longer be used must be disposed of in an environmentally friendly manner in accordance with the applicable country-specific waste disposal regulations. As it is categorized as electronic waste, the device must never be disposed of with household waste!

10.2 Returning devices

- ▶ Do not dispatch devices to the SICK Service department without consultation.



NOTE

To enable efficient processing and allow us to determine the cause quickly, please include the following when making a return:

- Details of the contact person
 - Description of the application
 - Description of the fault that occurred
-

11 Technical data

11.1 General data

Table 16: Technical data

| Attribute | Value | |
|---|--|--|
| Sensing distance | 13 mm | 25 mm |
| Sensing distance tolerance | ±5 mm | ±6 mm |
| Light spot size/light spot direction | longitudinal: 3.8 mm x 0.9 mm transverse: 0.9 mm x 3.8 mm round: 0.9 mm ² | longitudinal: 5.3 mm x 1.2 mm transverse: 1.2 mm x 5.3 mm |
| Supply voltage ¹ | 10.8 V – 28.8 V | |
| Switching frequency | 50 kHz 1-point teach-in (color mode): 16 kHz | |
| Response time | 10 µs 1-point teach-in (color mode): 30 µs | |
| Jitter | 5 µs 1-point teach-in (color mode): 15 µs | |
| Switching type | PNP or NPN or push/pull | |
| Switching output (Q) | PNP: HIGH = $U_V - 3 V$ / LOW = 0 V NPN: HIGH = U_V / LOW ≤ 3 V Push/pull: HIGH = $U_V - 3 V$ / LOW ≤ 3 V | |
| Input, teach-in (ET) | PNP and push/pull: Teach: $U = 10 V \dots < U_V$ Run: $U < 2 V$ NPN: Teach $U < 2 V$ Run: $U = 10 V \dots < U_V$ | |
| Input, blanking input (AT) – blanked/free | PNP and push/pull: Blanked: $U = 10 V \dots < U_V$ Free: $U < 2 V$ NPN: Blanked: $U < 2 V$ Free: $U = 10 V \dots < U_V$ | |
| Input, light/dark (L/D) | PNP and push/pull: Light switching: $U < 2 V$ Dark switching: $U = 10 V \dots < U_V$ NPN: Light switching: $U = 10 V \dots < U_V$ Dark switching: $U < 2 V$ | |
| Input, system sensitivity (F/C) | PNP and push/pull: Coarse: $U = 10 V \dots < U_V$ Fine: $U < 2 V$ NPN: Coarse: $U < 2 V$ Fine: $U = 10 V \dots < U_V$ | |

| Attribute | Value |
|---|--|
| Smart sensor functions | - Quality of Teach - Quality of Run - Process raw data readout - Automatic drift control - timestamp - adjustment aid - current operating temperature - Minimum/Maximum temperature over lifetime - job saving - teach cycle counter - working hour counter - LED monitoring (gedradation factor) for High Sensitivity versions |
| initialization time | < 150 ms |
| Enclosure rating | IP 67 |
| Ambient temperature (operation) | -20 °C ... +60 °C |
| Ambient temperature (UL) | max. 60 °C |
| Ambient temperature (storage) | -25 °C ... +75 °C |
| Protection class | III |
| Circuit protection | U _V connections, reverse polarity protected, output Q short-circuit protected, interference-pulse suppression |
| Max. output current of the switching output | 100 mA ² |

- ¹ Operation in short-circuit protected network max. 8 A
- ² Sum current of all digital outputs

Data for Smart Task (time stamp)



NOTE

A detailed description of the time stamp function can be found in the corresponding Smart Task operating instructions.

A time stamp function increases the temporal accuracy of detecting devices without using a high-speed network.

Table 17: Technical data, Smart Task

| Attribute | Value |
|---|--|
| Smart Task | Time stamp |
| General response time | SIO Direct: 10 µs ... 15 µs ¹ SIO Logic: 10 µs ... 15 µs ² IOL: - ³ |
| General repeatability | SIO Direct: 5 µs ¹ SIO Logic: 5 µs ² IOL: - ³ |
| Minimum time between two process events | SIO Direct: 20 µs ¹ SIO Logic: 20 µs ² IOL: 20 µs ³ |
| Time stamp accuracy | SIO Direct: - ¹ 3) SIO Logic: - ² 4) IOL: -65 ... +65 µs ³ |

| Attribute | Value |
|-------------------------------|---|
| Time stamp number buffer | SIO Direct: - SIO Logic: - IOL: 8 |
| Max. sensing range time stamp | SIO Direct: - SIO Logic: - IOL: 24 ms |
| Switching signal QL1 | Switching output |
| Switching signal QL2 | Switching output |
| Measured value | Time stamp |

- 1 SIO Direct: sensor operation in standard I/O mode without IO-Link communication and without use of sensor-internal logic or time parameters (set to "direct"/"deactivated")
- 2 Sensor operation in standard I/O mode without IO-Link communication. Use of sensor-internal logic and time parameters, plus automation functions
- 3 Sensor operation with full IO-Link communication and use of logic or time and automation function parameters

11.2 Dimensional drawings

KTS

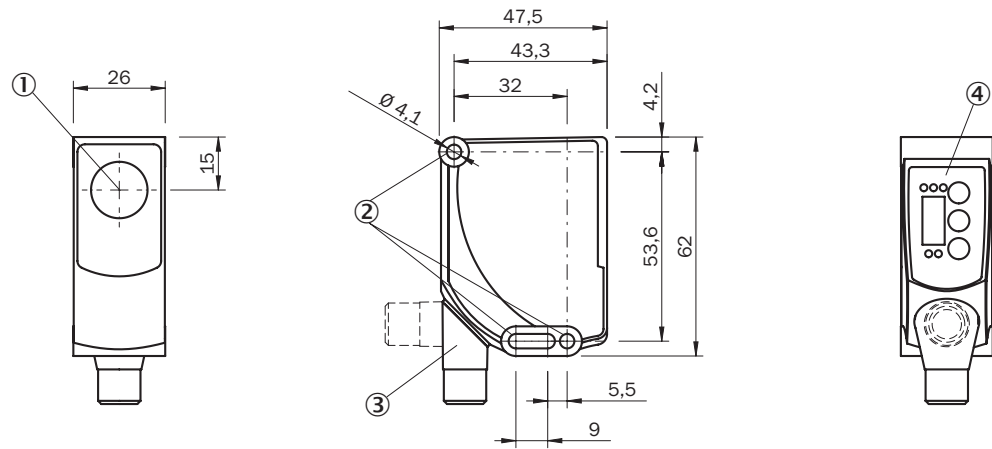

- ① Optical axis
- ② Fixing hole
- ③ M12 device connection, can be rotated by 180°
- ④ Control panel

KTX

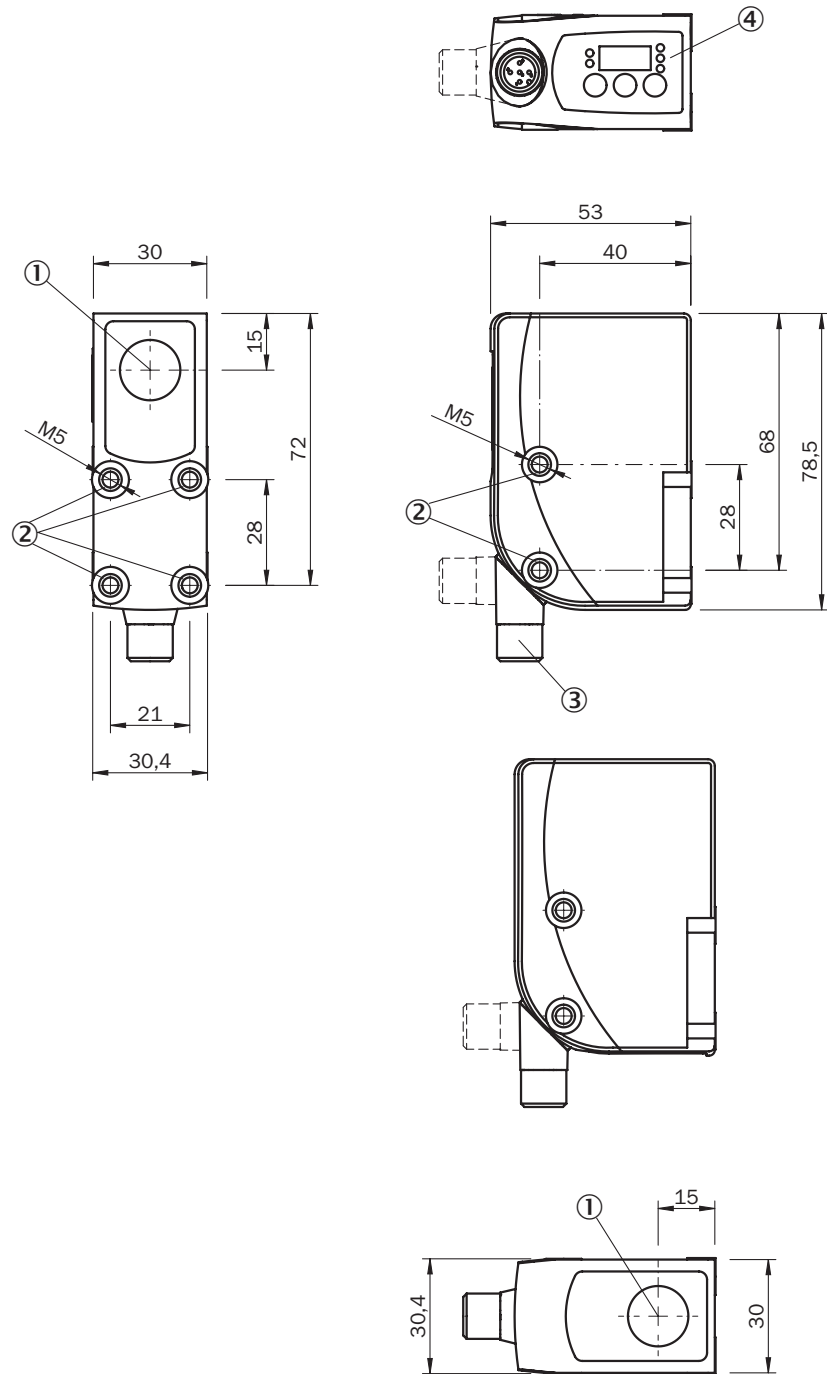

- ① Optical axis and light emission long/short housing side
- ② M5 threaded mounting hole
- ③ M12 device connection, can be rotated by 180°
- ④ Control panel

12 Accessories

**NOTE**

Accessories can be found on the online product page at:

- ▶ www.sick.com/KTS_Prime
 - ▶ www.sick.com/KTX_Prime
-

13 Annex

13.1 EU declaration of conformity and certificates

The EU declaration of conformity and other certificates can be downloaded from the Internet at:

- ▶ www.sick.com/KTS_Prime
- ▶ www.sick.com/KTX_Prime

13.2 Certification according to UL 60947-5-2



The contrast sensors of the KTS/KTX Prime and KTS Core series are certified in accordance with UL 60947-5-2 if they are supplied with power by LPS or Class 2 power supply units.

The certification is only valid with corresponding device identification on the type label of the respective device.

13.3 Licences

SICK uses open-source software. This software is licensed by the rights holders using the following licenses among others: the free licenses GNU General Public License (GPL Version2, GPL Version3) and GNU Lesser General Public License (LGPL), the MIT license, zLib license, and the licenses derived from the BSD license.

This program is provided for general use, but WITHOUT ANY WARRANTY OF ANY KIND. This warranty disclaimer also extends to the implicit assurance of marketability or suitability of the program for a particular purpose.

More details can be found in the GNU General Public License. View the complete license texts here: www.sick.com/licensetexts. Printed copies of the license texts are also available on request.

Australia

Phone +61 (3) 9457 0600
1800 33 48 02 – tollfree
E-Mail sales@sick.com.au

Austria

Phone +43 (0) 2236 62288-0
E-Mail office@sick.at

Belgium/Luxembourg

Phone +32 (0) 2 466 55 66
E-Mail info@sick.be

Brazil

Phone +55 11 3215-4900
E-Mail comercial@sick.com.br

Canada

Phone +1 905.771.1444
E-Mail cs.canada@sick.com

Czech Republic

Phone +420 234 719 500
E-Mail sick@sick.cz

Chile

Phone +56 (2) 2274 7430
E-Mail chile@sick.com

China

Phone +86 20 2882 3600
E-Mail info.china@sick.net.cn

Denmark

Phone +45 45 82 64 00
E-Mail sick@sick.dk

Finland

Phone +358-9-25 15 800
E-Mail sick@sick.fi

France

Phone +33 1 64 62 35 00
E-Mail info@sick.fr

Germany

Phone +49 (0) 2 11 53 010
E-Mail info@sick.de

Greece

Phone +30 210 6825100
E-Mail office@sick.com.gr

Hong Kong

Phone +852 2153 6300
E-Mail ghk@sick.com.hk

Hungary

Phone +36 1 371 2680
E-Mail ertesites@sick.hu

India

Phone +91-22-6119 8900
E-Mail info@sick-india.com

Israel

Phone +972 97110 11
E-Mail info@sick-sensors.com

Italy

Phone +39 02 27 43 41
E-Mail info@sick.it

Japan

Phone +81 3 5309 2112
E-Mail support@sick.jp

Malaysia

Phone +603-8080 7425
E-Mail enquiry.my@sick.com

Mexico

Phone +52 (472) 748 9451
E-Mail mexico@sick.com

Netherlands

Phone +31 (0) 30 229 25 44
E-Mail info@sick.nl

New Zealand

Phone +64 9 415 0459
0800 222 278 – tollfree
E-Mail sales@sick.co.nz

Norway

Phone +47 67 81 50 00
E-Mail sick@sick.no

Poland

Phone +48 22 539 41 00
E-Mail info@sick.pl

Romania

Phone +40 356-17 11 20
E-Mail office@sick.ro

Russia

Phone +7 495 283 09 90
E-Mail info@sick.ru

Singapore

Phone +65 6744 3732
E-Mail sales.gsg@sick.com

Slovakia

Phone +421 482 901 201
E-Mail mail@sick-sk.sk

Slovenia

Phone +386 591 78849
E-Mail office@sick.si

South Africa

Phone +27 10 060 0550
E-Mail info@sickautomation.co.za

South Korea

Phone +82 2 786 6321/4
E-Mail infokorea@sick.com

Spain

Phone +34 93 480 31 00
E-Mail info@sick.es

Sweden

Phone +46 10 110 10 00
E-Mail info@sick.se

Switzerland

Phone +41 41 619 29 39
E-Mail contact@sick.ch

Taiwan

Phone +886-2-2375-6288
E-Mail sales@sick.com.tw

Thailand

Phone +66 2 645 0009
E-Mail marcom.th@sick.com

Turkey

Phone +90 (216) 528 50 00
E-Mail info@sick.com.tr

United Arab Emirates

Phone +971 (0) 4 88 65 878
E-Mail contact@sick.ae

United Kingdom

Phone +44 (0)17278 31121
E-Mail info@sick.co.uk

USA

Phone +1 800.325.7425
E-Mail info@sick.com

Vietnam

Phone +65 6744 3732
E-Mail sales.gsg@sick.com

Detailed addresses and further locations at www.sick.com