

# WSE9(M4)-3

Small photoelectric sensor

en / de / fr / pt / it / es / zh / ja / ru

**SICK**  
Sensor Intelligence.



# Through-beam photoelectric sensor

## Operating instructions

### 1 Safety notes

- Read the operating instructions before commissioning.
- Connection, mounting, and setting may only be performed by trained specialists.
- Not a safety component in accordance with the EU Machinery Directive.
- UL: Only for use in applications in accordance with NFPA 79. Adapters listed by UL with connection cables are available. Enclosure type 1.
- When commissioning, protect the device from moisture and contamination.
- These operating instructions contain information required during the life cycle of the sensor.

### 2 Correct use

The WSE9(M4)-3 is an opto-electronic through-beam photoelectric sensor (referred to as "sensor" in the following) for the optical, non-contact detection of objects, animals, and persons. A sender (WS) and a receiver (WE) are required for operation. If the product is used for any other purpose or modified in any way, any warranty claim against SICK AG shall become void.

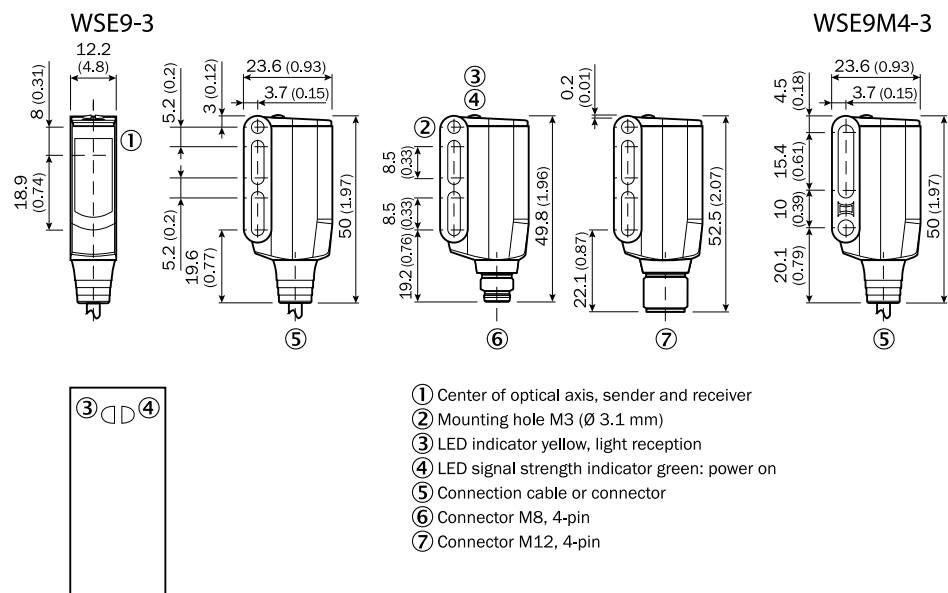

### 3 Commissioning

- 1 Observe the application conditions: Adjust the distance between the sender and the receiver according to the corresponding diagram [H] (x = sensing range, y = operating reserve).  
If several through-beam photoelectric sensors which are installed next to one another are to be used, we recommend swapping the sender / receiver arrangement at every second through-beam photoelectric sensor and ensuring that there is sufficient distance between the through-beam photoelectric sensors. By doing this, mutual interference can be prevented [cf. F].

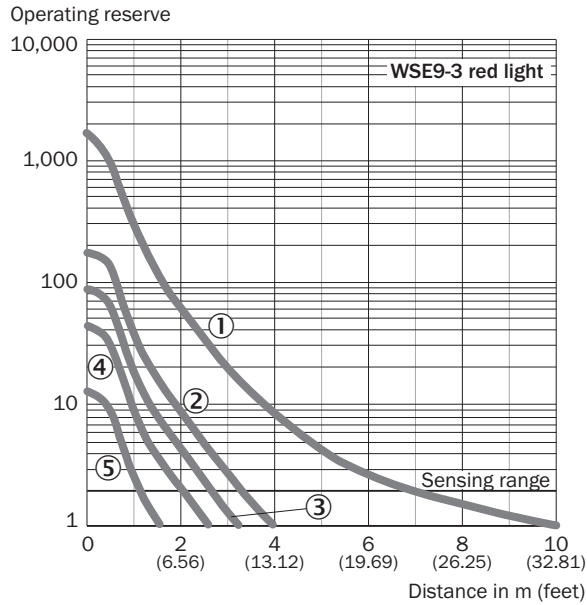

Image: H

- 2 Mount sensors (sender and receiver) using suitable mounting brackets (see the SICK range of accessories). Align the sender and receiver with each other. Note the sensor's maximum permissible tightening torque of 0.6 Nm.
- 3 The sensors must be connected in a voltage-free state ( $V_S = 0$  V). The information in the graphics [B] must be observed, depending on the type of connection:
  - Male connector connection: pin assignment
  - Cable: core color

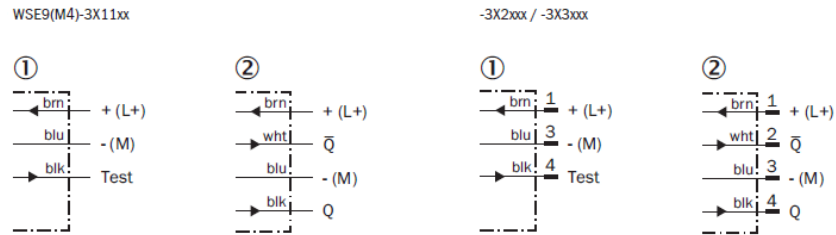

Image: B

Only apply voltage / switch on the power supply ( $V_S > 0$  V) once all electrical connections have been completed. The green LED indicator lights up on the sensor.

Explanations of the connection diagram (graphic B):

Switching outputs Q and /Q (according to graphic B):

WSE9(M4)-3P (PNP: load -> M)

WSE9(M4)-3N (NPN: load -> L+)

TE / Test = test input (see Additional functions)

- 4 Align the sender with the receiver. Select the position so that the red emitted light beam hits the receiver. Tip: Use white paper or a reflector as an alignment aid. The sender must have a clear view of the receiver, with no object in the path of the beam [see E]. You must ensure that the optical openings (front screen) of the sensors are completely clear.

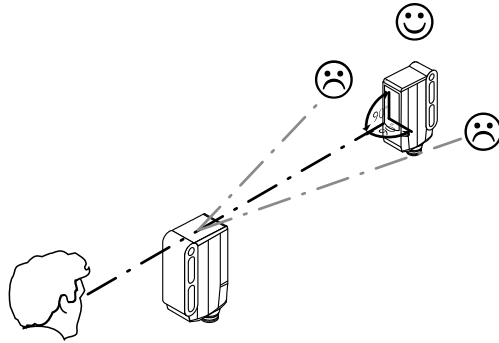

Image: E

- 5 Sensor which it is not possible to set for the WL9(M4)-3Xxxx0: The sensor is adjusted and ready for operation. Refer to Graphics C and G to check the function. If the switching output fails to behave in accordance with Graphic C, check application conditions. See section Fault diagnosis.

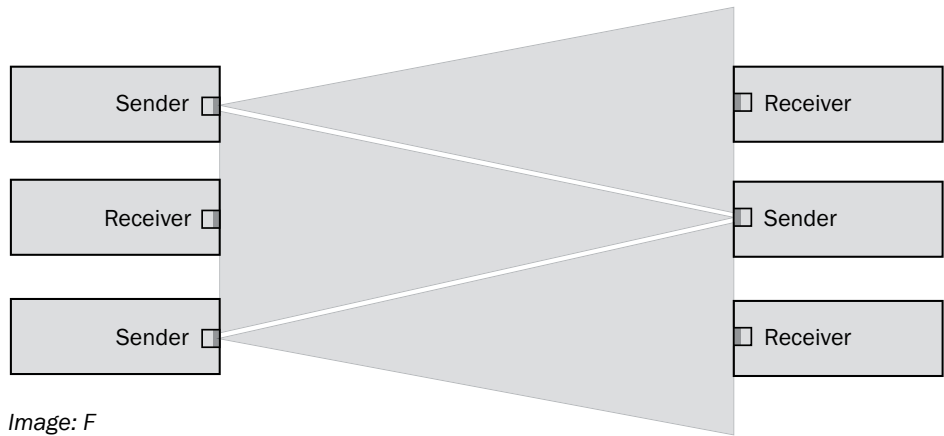

Image: F

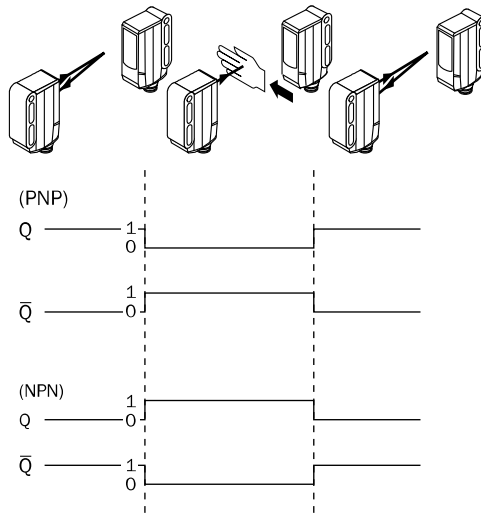

Image: C

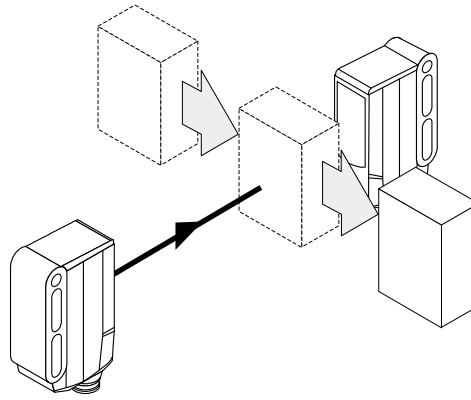

Image: G

## 5 Additional functions

**Test input:** The WSE9(M4)-3 sensor features a test input ("TI" or "Test" on the connection diagram [B]), which can be used to check that the sensor is functioning correctly: If female cable connectors with LED indicators are used, you must ensure that the TI is assigned accordingly.

There must be no object between the sender and receiver; activate the test input (see the connection diagram [B], TI at 0 V). The send LED is shut down or the detection of an object is simulated. Refer to Graphics C and G to check the function. If the switching output fails to behave in accordance with Graphic C, check application conditions. See section Fault diagnosis.

## 6 Devices with special features

WSE9M4-3P3410S02: High-power IR, increased operating reserve, sensing range max. 13 m, light spot size 140 mm (1 m distance), response time < 1 ms, switching frequency 500 Hz

## 7 Fault diagnosis

Table indicates which measures are to be taken if the sensor stops working.

## 8 Table Fault diagnosis

LED indicator/fault pattern / LED indicator/fault pattern	Cause / Cause	Measures / Measures
Green LED does not light up / Green LED does not light up	No voltage or voltage below the limit values / No voltage or voltage below the limit values	Check the power supply, check all electrical connecti- ons (cables and plug connecti- ons) / Check the power supply, check all electrical connecti- ons (cables and plug connecti- ons)
Green LED does not light up / Green LED does not light up	Voltage interruptions / Voltage interruptions	Ensure there is a stable power supply without interruptions / Ensure there is a stable power supply without interruptions

LED indicator/fault pattern / LED indicator/fault pattern	Cause / Cause	Measures / Measures
Green LED does not light up / Green LED does not light up	Sensor is faulty / Sensor is faulty	If the power supply is OK, re- place the sensor / If the power supply is OK, re- place the sensor
Green LED lights up, no output signal when object is detec- ted / Green LED lights up, no output signal when object is detected	Test input (TI) is not connec- ted properly / Test input (TI) is not connec- ted properly	See the note on connecting the TI / See the note on connecting the TI
Yellow LED flashes / Yellow LED flashes	Sensor is still ready for opera- tion, but the operating condi- tions are not ideal / Sensor is still ready for opera- tion, but the operating condi- tions are not ideal	Check the operating condi- tions: Fully align the beam of light (light spot) with the recei- ver. / Clean the optical surfa- ces . / Readjust the sensitivi- ty / Check sensing range and adjust if necessary; see gra- phic H. / Check the operating condi- tions: Fully align the beam of light (light spot) with the recei- ver. / Clean the optical surfa- ces . / Readjust the sensitivi- ty / Check sensing range and adjust if necessary; see gra- phic H.
Yellow LED lights up, no object in the path of the beam / Yellow LED lights up, no object in the path of the beam	The beam of light of a photo- electric through-beam sensor hits the receiver of another (neighboring) photoelectric through-beam sensor / The beam of light of a photo- electric through-beam sensor hits the receiver of another (neighboring) photoelectric through-beam sensor	Swap the sender and receiver arrangement at every se- cond photoelectric through- beam sensor and ensure that there is sufficient distance between the through-beam photoelectric sensors / Swap the sender and receiver arrangement at every se- cond photoelectric through- beam sensor and ensure that there is sufficient distance between the through-beam photoelectric sensors

## 9 Disassembly and disposal

The sensor must be disposed of according to the applicable country-specific regulations. Efforts should be made during the disposal process to recycle the constituent materials (particularly precious metals).

## 10 Maintenance

SICK sensors are maintenance-free.

We recommend doing the following regularly:

- Clean the external lens surfaces
- Check the screw connections and plug-in connections

No modifications may be made to devices.

---

Subject to change without notice. Specified product properties and technical data are not written guarantees.

# Einweg-Lichtschanke

## Betriebsanleitung

### 11 Sicherheitshinweise

- Vor der Inbetriebnahme die Betriebsanleitung lesen.
- Anschluss, Montage und Einstellung nur durch Fachpersonal.
- Kein Sicherheitsbauteil gemäß EU-Maschinenrichtlinie.
- UL: Nur zur Verwendung in Anwendungen gemäß NFPA 79. Von UL gelistete Adapter mit Anschlusskabeln sind verfügbar. Enclosure type 1.
- Gerät bei Inbetriebnahme vor Feuchte und Verunreinigung schützen.
- Diese Betriebsanleitung enthält Informationen, die während des Lebenszyklus des Sensors notwendig sind.

### 12 Bestimmungsgemäße Verwendung

Die WSE9(M4)-3 ist eine optoelektronische Einweg-Lichtschanke (im Folgenden Sensor genannt) und wird zum optischen, berührungslosen Erfassen von Sachen, Tieren und Personen eingesetzt. Zum Betrieb ist ein Sender (WS) und ein Empfänger (WE) erforderlich. Bei jeder anderen Verwendung und bei Veränderungen am Produkt verfällt jeglicher Gewährleistungsanspruch gegenüber der SICK AG.

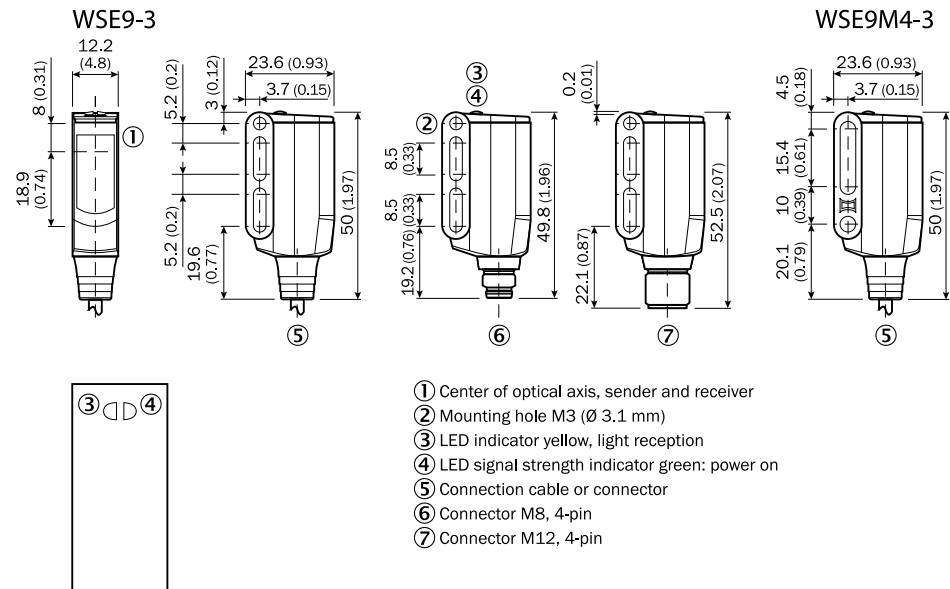

### 13 Inbetriebnahme

- 1 Einsatzbedingungen beachten: Distanz zwischen Sender und Empfänger mit dem zugehörigen Diagramm [vgl. H] abgleichen (x = Schaltabstand, y = Funktionsreserve).  
Beim Einsatz von mehreren Einweg-Lichtschraken, die nebeneinander installiert werden, empfehlen wir, bei jeder zweiten Einweg-Lichtschanke die Anordnung von Sender und Empfänger zu tauschen, bzw. genügend Abstand zwischen den Einweg-Lichtschraken einzuhalten. Damit können gegenseitige Beeinflussungen vermieden werden [vgl. F].





Abb.: H

- 2 Sensoren (Sender und Empfänger) an geeignete Befestigungswinkel montieren (siehe SICK-Zubehör-Programm). Sender und Empfänger zueinander ausrichten. Maximal zulässiges Anzugsdrehmoment des Sensors von 0.6 Nm beachten.
- 3 Anschluss der Sensoren muss spannungsfrei ( $U_V = 0\text{ V}$ ) erfolgen. Je nach Anschlussart sind die Informationen in den Grafiken [vgl. B] zu beachten:
  - Steckeranschluss: Pinbelegung
  - Leitung: Adernfarbe

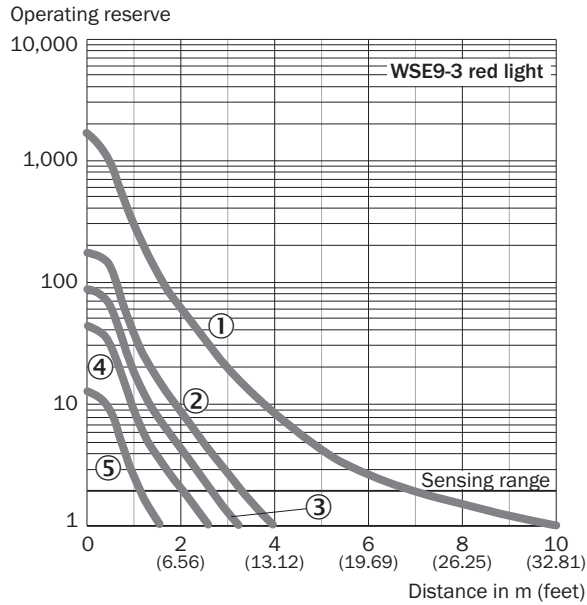

Abb.: B

Erst nach Anschluss aller elektrischen Verbindungen die Spannungsversorgung ( $U_V > 0\text{ V}$ ) anlegen bzw. einschalten. Am Sensor leuchtet die grüne Anzeige-LED.

Erläuterungen zum Anschlussschema (Grafik B):

Schaltausgänge Q bzw. /Q (gemäß Grafik B):

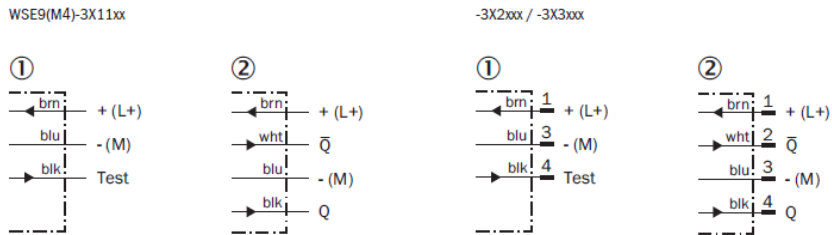
WSE9(M4)-3P (PNP: Last -> M)

WSE9(M4)-3N (NPN: Last -> L+)

TE / Test = Testeingang (siehe Zusatzfunktionen)

- 4 Sender auf Empfänger ausrichten. Positionierung so wählen, dass der rote Sendelichtstrahl auf den Empfänger auftrifft. Tipp: weißes Papier oder Reflektor als Ausrichthilfe verwenden. Der Sender muss freie Sicht auf den Empfänger haben, es darf sich kein Objekt im Strahlengang befinden [vgl. E]. Es ist darauf zu achten, dass die optischen Öffnungen (Frontscheiben) der Sensoren vollständig frei sind.



Abb.: E

- 5 Sensor ohne Einstellmöglichkeit WL9(M4)-3Xxxx0: Sensor ist eingestellt und betriebsbereit.  
 Zur Überprüfung der Funktion Grafik C und G heranziehen. Verhält sich der Schaltausgang nicht gemäß Grafik C, Einsatzbedingungen prüfen. Siehe Abschnitt Fehlerdiagnose.



Abb.: F

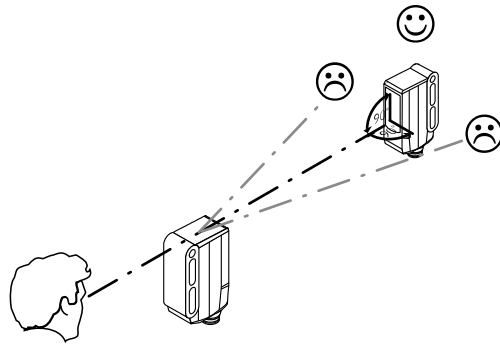

Abb.: C

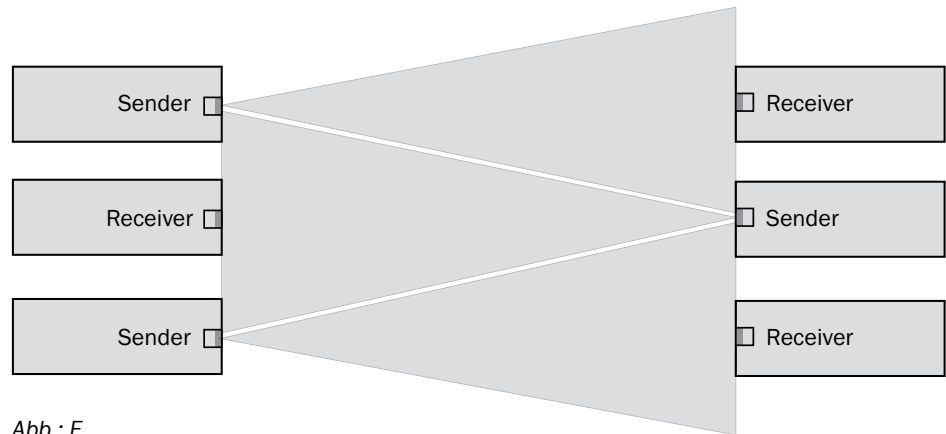

Abb.: G

## 15 Zusatzfunktionen

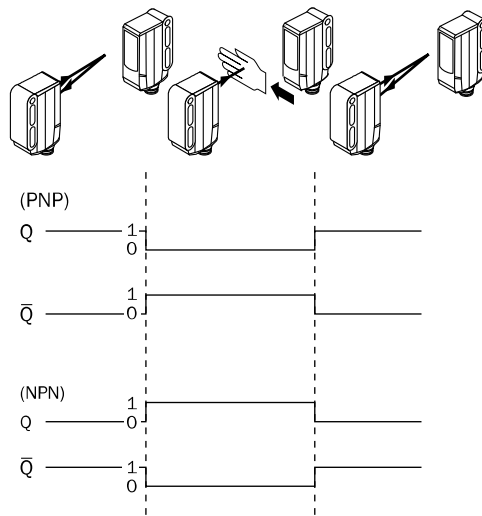
**Testeingang:** Der Sensor WSE9(M4)-3 verfügt über einen Testeingang („TE“ oder „Test“ im Anschlussschema [B]), mit dem die ordnungsgemäße Funktion des Sensors überprüft werden kann: Bei Verwendung von Leitungsdosen mit LED-Anzeigen ist darauf zu achten, dass der TE entsprechend belegt ist.

Es darf sich kein Objekt zwischen Sender und Empfänger befinden, Testeingang aktivieren (siehe Anschlussschema [B], TE nach 0 V). Sende-LED wird abgeschaltet, bzw. es wird simuliert, dass ein Objekt erkannt wird. Zur Überprüfung der Funktion Grafik C und G heranziehen. Verhält sich der Schaltausgang nicht gemäß Grafik C, Einsatzbedingungen prüfen. Siehe Abschnitt Fehlerdiagnose.

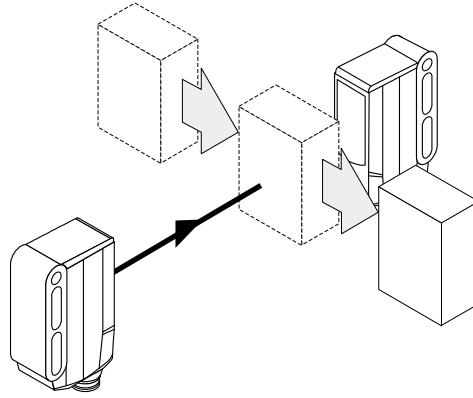
## 16 Geräte mit besonderen Merkmalen

WSE9M4-3P3410S02: High-Power-IR, gesteigerte Funktionsreserve, Schaltabstand max. 13 m, Lichtfleckgröße 140 mm (1m Entfernung), Ansprechzeit < 1 ms, Schaltfrequenz 500 Hz

## 17 Fehlerdiagnose

Tabelle I zeigt, welche Maßnahmen durchzuführen sind, wenn die Funktion des Sensors nicht mehr gegeben ist.

## 18 Tabelle Fehlerdiagnose

Anzeige-LED / Fehlerbild / LED indicator/fault pattern	Ursache / Cause	Maßnahme / Measures
grüne LED leuchtet nicht / Green LED does not light up	keine Spannung oder Spannung unterhalb der Grenzwerte / No voltage or voltage below the limit values	Spannungsversorgung prüfen, den gesamten elektrischen Anschluss prüfen (Leitungen und Steckerverbindungen) / Check the power supply, check all electrical connections (cables and plug connections)
grüne LED leuchtet nicht / Green LED does not light up	Spannungsunterbrechungen / Voltage interruptions	Sicherstellen einer stabilen Spannungsversorgung ohne Unterbrechungen /

Anzeige-LED / Fehlerbild / LED indicator/fault pattern	Ursache / Cause	Maßnahme / Measures
		Ensure there is a stable power supply without interruptions
grüne LED leuchtet nicht / Green LED does not light up	Sensor ist defekt / Sensor is faulty	Wenn Spannungsversorgung in Ordnung ist, dann Sensor austauschen / If the power supply is OK, replace the sensor
grüne LED leuchtet, kein Ausgangssignal bei Objektdetektion / Green LED lights up, no output signal when object is detected	Testeingang (TE) ist nicht korrekt angeschlossen / Test input (TI) is not connected properly	Siehe Hinweis für Anschluss des TE / See the note on connecting the TI
gelbe LED blinkt / Yellow LED flashes	Sensor ist noch betriebsbereit, aber die Betriebsbedingungen sind nicht optimal / Sensor is still ready for operation, but the operating conditions are not ideal	Betriebsbedingungen prüfen: Lichtstrahl (Lichtfleck) vollständig auf den Empfänger ausrichten / Reinigung der optischen Flächen / Empfindlichkeit neu einstellen / Schaltabstand überprüfen und ggf. anpassen, siehe Grafik H. / Check the operating conditions: Fully align the beam of light (light spot) with the receiver. / Clean the optical surfaces. / Readjust the sensitivity / Check sensing range and adjust if necessary; see graphic H.
gelbe LED leuchtet, kein Objekt im Strahlengang / Yellow LED lights up, no object in the path of the beam	Der Lichtstrahl einer Einweg-Lichtschanke trifft auf den Empfänger einer anderen (benachbarten) Einweg-Lichtschanke / The beam of light of a photoelectric through-beam sensor hits the receiver of another (neighboring) photoelectric through-beam sensor	Bei jeder zweiten Einweg-Lichtschanke die Anordnung von Sender und Empfänger tauschen, bzw. genügend Abstand zwischen den Einweg-Lichtschanken einhalten. / Swap the sender and receiver arrangement at every second photoelectric through-beam sensor and ensure that there is sufficient distance between the through-beam photoelectric sensors

## 19 Demontage und Entsorgung

Die Entsorgung des Sensors hat gemäß den länderspezifisch anwendbaren Vorschriften zu erfolgen. Für die enthaltenen Wertstoffe (insbesondere Edelmetalle) ist im Rahmen der Entsorgung eine Verwertung anzustreben.

## 20 Wartung

SICK-Sensoren sind wartungsfrei.

Wir empfehlen, in regelmäßigen Abständen

- die optischen Grenzflächen zu reinigen
- Verschraubungen und Steckverbindungen zu überprüfen

---

Veränderungen an Geräten dürfen nicht vorgenommen werden.

Irrtümer und Änderungen vorbehalten. Angegebene Produkteigenschaften und technische Daten stellen keine Garantieerklärung dar.

# Barrière émetteur-récepteur

## Notice d'instruction

### 21 Consignes de sécurité

- Lire la notice d'instruction avant la mise en service.
- Confier le raccordement, le montage et le réglage uniquement à un personnel spécialisé.
- Il ne s'agit pas d'un composant de sécurité au sens de la directive machines CE.
- UL : utilisation uniquement dans des applications selon la NFPA 79. Des adaptateurs listés UL avec câbles de connexion sont disponibles. Enclosure type 1.
- Protéger l'appareil contre l'humidité et les impuretés lors de la mise en service.
- Cette notice d'instruction contient des informations nécessaires pendant toute la durée de vie du capteur.

### 22 Utilisation conforme

WSE9(M4)-3 est une barrière émetteur-récepteur optoélectronique (appelée capteur dans ce document) qui permet la détection optique sans contact d'objets, d'animaux et de personnes. Un émetteur (WS) et un récepteur (WE) sont nécessaires à son fonctionnement. Toute autre utilisation ou modification du produit annule la garantie de SICK AG.

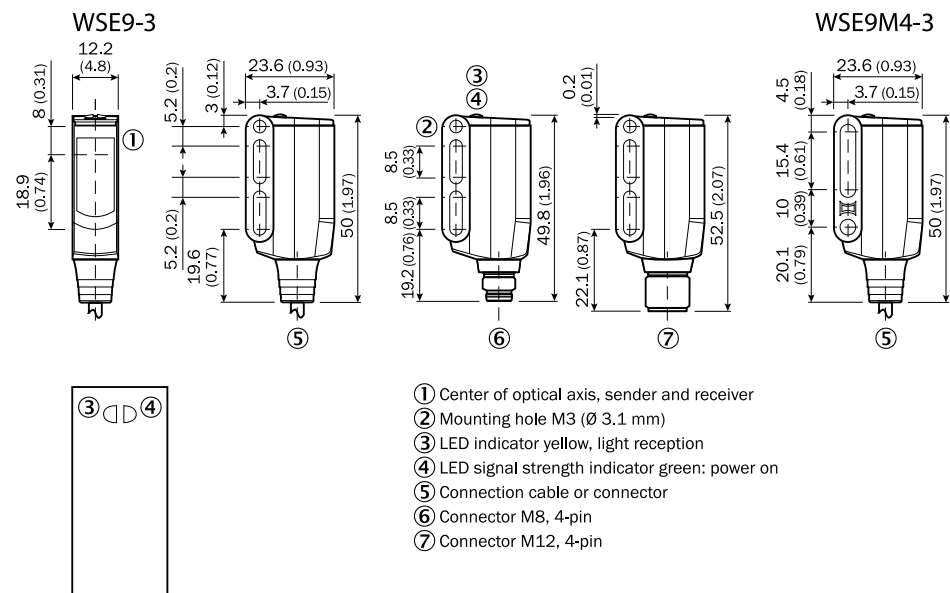

### 23 Mise en service

- 1 Respecter les conditions d'utilisation : comparer la distance entre l'émetteur et le récepteur avec le diagramme correspondant [voir H] (x = portée, y = réserve de fonctionnement).  
Si plusieurs barrières émetteur-récepteur sont installées les unes à côté des autres, nous recommandons d'invertir la place de l'émetteur et du récepteur une fois sur deux ou de laisser suffisamment d'espace entre les barrières émetteur-récepteur. Ceci permet d'éviter les interférences mutuelles [voir F].

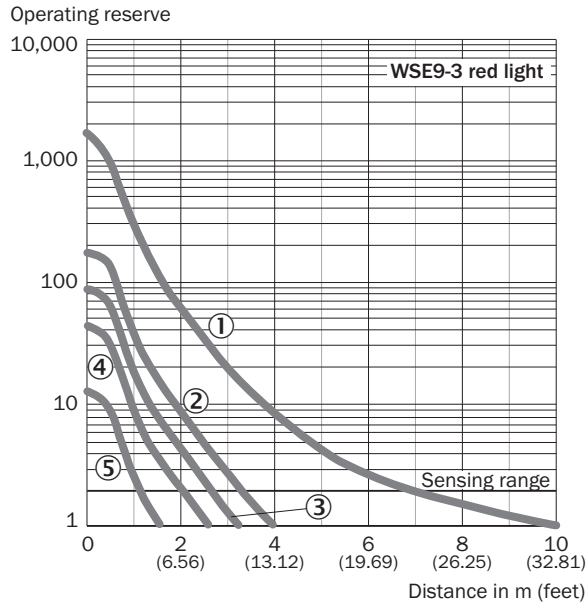

Image: H

- 2 Monter les capteurs (émetteur et récepteur) sur des équerres de fixation adaptées (voir la gamme d'accessoires SICK). Aligner l'émetteur sur le récepteur. Respecter le couple de serrage maximum autorisé du capteur de 0.6 Nm
- 3 Le raccordement des capteurs doit s'effectuer hors tension ( $U_V = 0 V$ ). Selon le mode de raccordement, respecter les informations contenues dans les schémas [B] :
  - Raccordement du connecteur : affectation des broches
  - Câble : couleur des fils

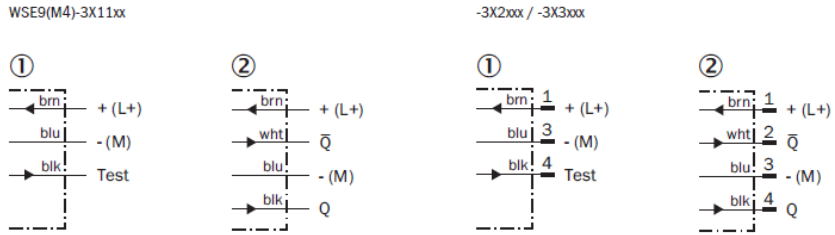

Image: B

Après avoir terminé tous les raccordements électriques, enclencher l'alimentation électrique ( $U_V > 0 V$ ). La DEL verte s'allume sur le capteur.

Explications relatives au schéma de raccordement (schéma B) :

Sorties de commutation Q ou /Q (selon le schéma B) :

WSE9(M4)-3P (PNP : charge -> M)

WSE9(M4)-3N (NPN : charge -> L+)

TE / Test = entrée test (voir fonctions supplémentaires)

- 4 Aligner l'émetteur sur le récepteur. Sélectionner la position de sorte que le faisceau lumineux émis rouge touche le récepteur. Conseil : utiliser un morceau de papier blanc ou le réflecteur comme outil d'alignement. L'émetteur doit disposer d'un champ de vision dégagé sur le récepteur, il ne doit donc y avoir aucun objet dans la trajectoire du faisceau [voir E]. S'assurer que les ouvertures optiques (vitres frontales) des capteurs sont parfaitement dégagées.

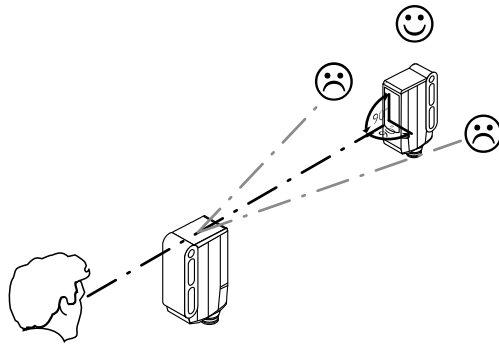

Image: E

- 5 Capteur sans possibilité de réglage WL9(M4)-3Xxxx0 : le capteur est réglé et prêt à l'emploi.

Pour contrôler le fonctionnement, utiliser les schémas C et G. Si la sortie de commutation ne se comporte pas comme indiqué sur le schéma C, vérifier les conditions d'utilisation. Voir la section consacrée au diagnostic.

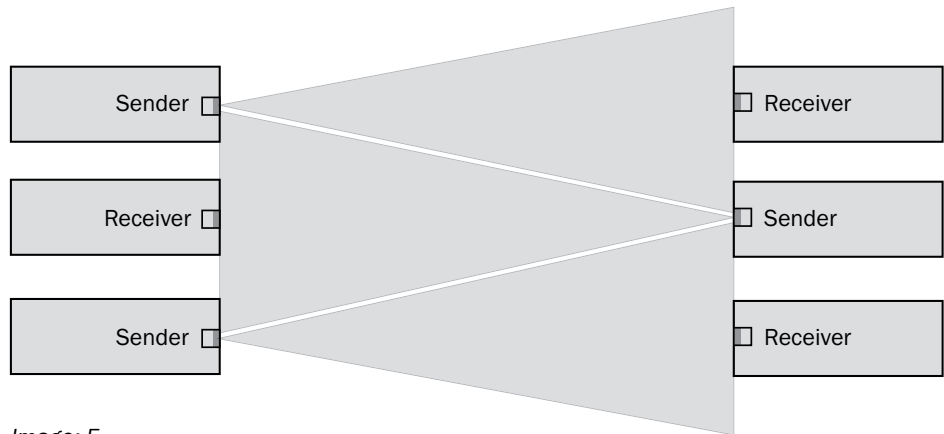

Image: F

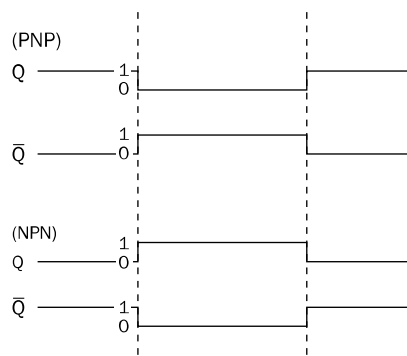
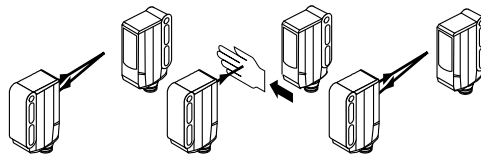

Image: C



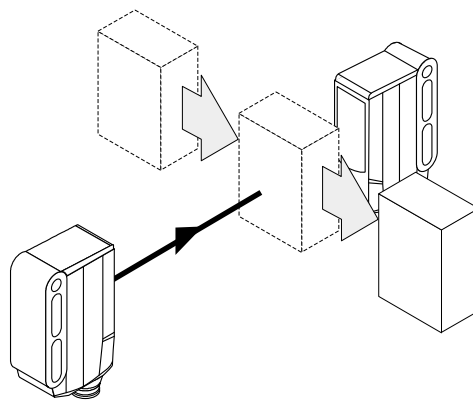

Image: G

## 25 Fonctions supplémentaires

Entrée test : le capteur WSE9(M4)-3 dispose d'une entrée test (« TE » ou « Test » dans le schéma de raccordement [B]) qui permet de contrôler le bon fonctionnement du capteur : lorsque des câbles avec connecteurs femelles équipés de DEL sont utilisés, s'assurer que l'entrée TE est correctement affectée.

Aucun objet ne doit se trouver entre l'émetteur et le récepteur ; activer l'entrée test (voir le schéma de raccordement [B], TE sur 0 V). La LED d'émission est arrêtée ou une détection d'objet est simulée. Pour contrôler le fonctionnement, utiliser les schémas C et G. Si la sortie de commutation ne se comporte pas comme indiqué sur le schéma C, vérifier les conditions d'utilisation. Voir la section consacrée au diagnostic.

## 26 Appareils avec caractéristiques spécifiques

WSE9M4-3P3410S02 : IR haute puissance, réserve fonctionnelle accrue, portée max. de 13 m, taille du spot lumineux 140 mm (distance 1 m), temps de réponse < 1 ms, fréquence de commutation de 500 Hz

## 27 Diagnostic

Le tableau I présente les mesures à appliquer si le capteur ne fonctionne plus.

## 28 Tableau Diagnostic

LED d'état / image du défaut / LED indicator/fault pattern	Cause / Cause	/ Mesures
La LED verte ne s'allume pas / Green LED does not light up	Pas de tension ou tension inférieure aux valeurs limites / No voltage or voltage below the limit values	Contrôler l'alimentation électrique, contrôler tous les branchements électriques (câbles et connexions) / Check the power supply, check all electrical connections (cables and plug connections)
La LED verte ne s'allume pas / Green LED does not light up	Coupures d'alimentation électrique / Voltage interruptions	S'assurer que l'alimentation électrique est stable et ininterrompue /

LED d'état / image du défaut / LED indicator/fault pattern	Cause / Cause	/ Measures
		Ensure there is a stable power supply without interruptions
La LED verte ne s'allume pas / Green LED does not light up	Le capteur est défectueux / Sensor is faulty	Si l'alimentation électrique est en bon état, remplacer le capteur / If the power supply is OK, replace the sensor
La LED verte s'allume, pas de signal de sortie en cas de détection d'objet / Green LED lights up, no output signal when object is detected	L'entrée test (TE) n'est pas correctement raccordée / Test input (TI) is not connected properly	Voir les informations sur le raccordement de l'entrée test / See the note on connecting the TI
La LED jaune clignote / Yellow LED flashes	Le capteur est encore opérationnel, mais les conditions d'utilisation ne sont pas idéales / Sensor is still ready for operation, but the operating conditions are not ideal	Vérifier les conditions d'utilisation : Diriger le faisceau lumineux (spot lumineux) entièrement sur le récepteur / Nettoyage des surfaces optiques / Régler à nouveau la sensibilité / Contrôler la portée et éventuellement l'adapter, voir le schéma et H. / Check the operating conditions: Fully align the beam of light (light spot) with the receiver. / Clean the optical surfaces. / Readjust the sensitivity / Check sensing range and adjust if necessary; see graphic H.
La LED jaune s'allume, pas d'objet dans la trajectoire du faisceau / Yellow LED lights up, no object in the path of the beam	Le faisceau lumineux d'une barrière émetteur-récepteur atteint le récepteur d'une autre barrière émetteur-récepteur (voisine) / The beam of light of a photoelectric through-beam sensor hits the receiver of another (neighboring) photoelectric through-beam sensor	Pour une barrière émetteur-récepteur sur deux, intervertir la place de l'émetteur et du récepteur ou laisser suffisamment d'espace entre les barrières émetteur-récepteur. / Swap the sender and receiver arrangement at every second photoelectric through-beam sensor and ensure that there is sufficient distance between the through-beam photoelectric sensors

## 29 Démontage et mise au rebut

La mise au rebut du capteur doit respecter la réglementation nationale en vigueur. Dans le cadre de la mise au rebut, veiller à recycler les matériaux (notamment les métaux précieux).

## 30 Maintenance

Les capteurs SICK ne nécessitent aucune maintenance.

Nous vous recommandons de procéder régulièrement

- au nettoyage des surfaces optiques
- au contrôle des vissages et des connexions enfichables

---

Ne procéder à aucune modification sur les appareils.

Sujet à modification sans préavis. Les caractéristiques du produit et techniques fournies ne sont pas une déclaration de garantie.

# Fotocélula unidirecional

## Manual de instruções

### 31 Notas de segurança

- Ler as instruções de operação antes da colocação em funcionamento.
- A conexão, a montagem e o ajuste devem ser executados somente por pessoal técnico qualificado.
- Os componentes de segurança não se encontram em conformidade com a Diretiva Europeia de Máquinas.
- UL: Somente na utilização em aplicações de acordo com NFPA 79. Estão disponíveis adaptadores listados pela UL com cabos de conexão. Enclosure type 1.
- Durante o funcionamento, manter o aparelho protegido contra impurezas e umidade.
- Este manual de instruções contém informações necessárias para toda a vida útil do sensor.

### 32 Especificações de uso

O WSE9(M4)-3 é uma barreira de luz unidirecional optoeletrônica (doravante denominada "sensor") utilizada para a detecção óptica, sem contato, de objetos, animais e pessoas. Para a operação, são necessários um emissor (WS) e um receptor (WE). Qualquer utilização diferente ou alterações do produto provocam a perda da garantia da SICK AG.

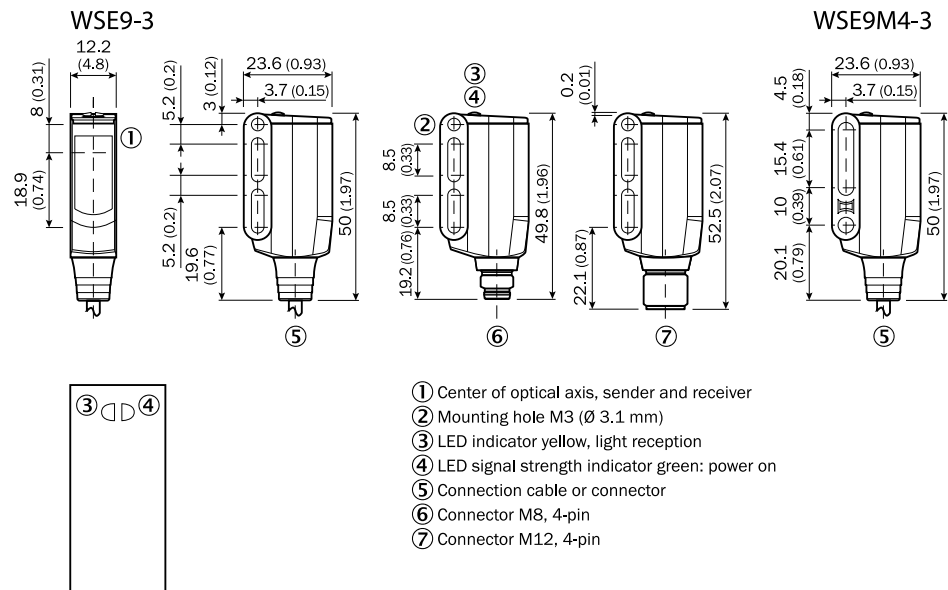

### 33 Colocação em funcionamento

- 1 Observar as condições de uso: equiparar a distância entre o emissor e o receptor com o respectivo diagrama [cp. H] (x = distância de comutação, y = reserva de função).

Na utilização de várias barreiras de luz unidirecionais, instaladas lado a lado, recomendamos trocar a disposição do emissor e do receptor a cada duas barreiras de luz ou manter uma distância suficiente entre as barreiras de luz unidirecionais. Isto permite evitar interferências recíprocas [cp. F].

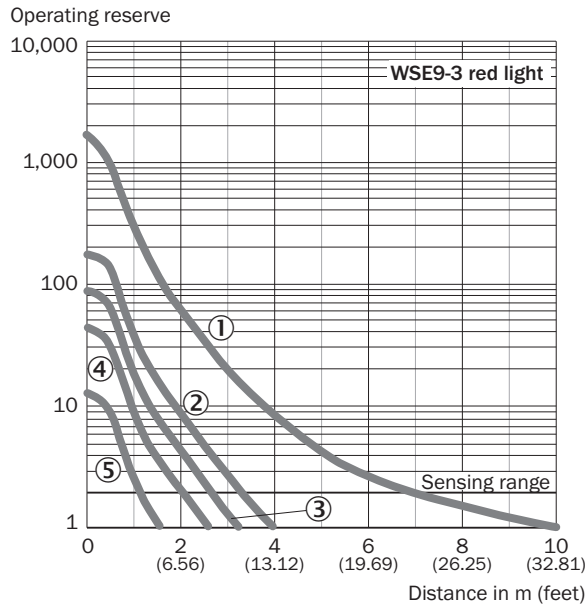

Image: H

- 2 Montar os sensores (emissor e receptor) em cantoneiras de fixação adequadas (ver linha de acessórios da SICK). Alinhar o emissor e o receptor entre si. Observar o torque de aperto máximo permitido de 0.6 Nm para o sensor.
- 3 A conexão dos sensores deve ser realizada em estado desenergizado ( $U_V = 0\text{ V}$ ). Conforme o tipo de conexão, devem ser observadas as informações contidas nos gráficos [cp. B]:
  - Conector: Pin-out
  - Cabo: Cor dos fios

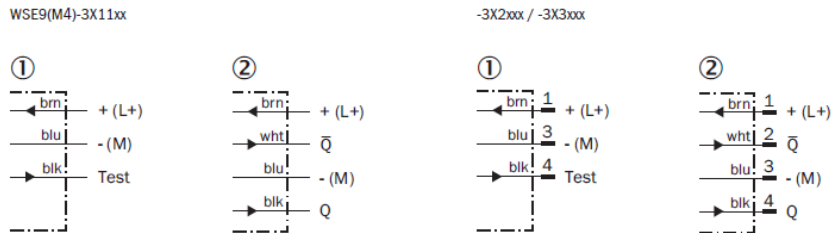

Image: B

Instalar ou ligar a alimentação de tensão ( $U_V > 0\text{ V}$ ) somente após a conclusão de todas as conexões elétricas. O indicador LED verde está aceso no sensor.

Explicações relativas ao esquema de conexões (Gráfico B):

Saídas de comutação Q ou /Q (conforme o gráfico B):

WSE9(M4)-3P (PNP: carga -> M)

WSE9(M4)-3N (NPN: carga -> L+)

TE / Test = Entrada de teste (ver Funções adicionais)

- 4 Alinhar o emissor ao receptor. Posicionar, de forma que o feixe da luz de emissão vermelha incida sobre o receptor. Dica: Utilizar um papel branco ou o refletor para auxiliar o alinhamento. O espaço entre o emissor e o receptor deve estar desimpedido; não pode haver objetos no caminho óptico [cp. E]. Certificar-se de que as aberturas ópticas (vidros frontais) dos sensores refletor estejam completamente livres.

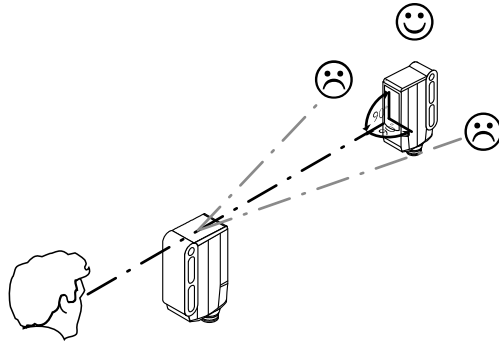

Image: E

- 5 Sensor sem possibilidade de ajuste WL9(M4)-3Xxxx0: sensor está ajustado e operacional.

Utilizar os gráficos C e G para verificar o funcionamento. Se a saída de comutação não se comportar de acordo com o gráfico C, verificar as condições de uso. Ver seção Diagnóstico de erros.

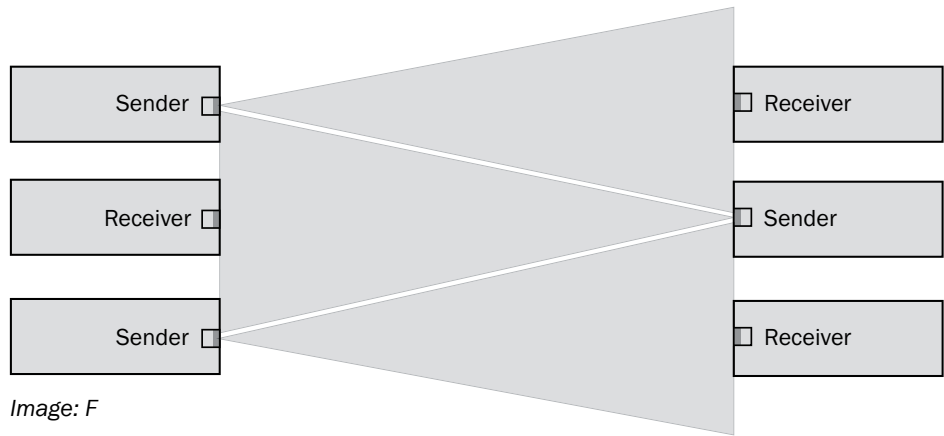

Image: F

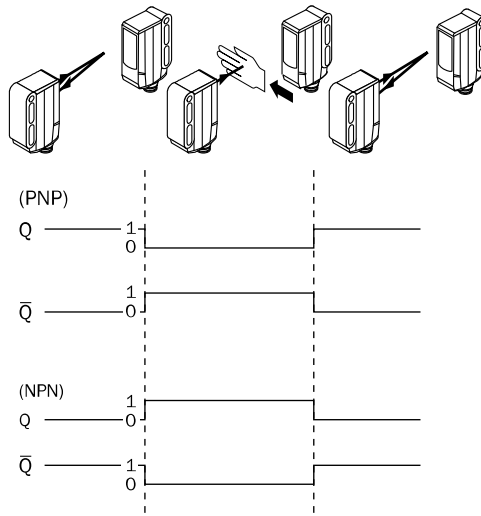

Image: C

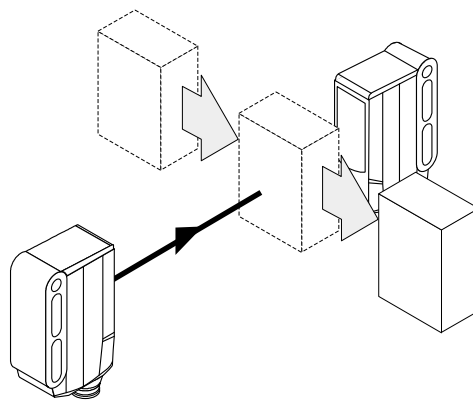

Image: G

## 35 Funções adicionais

Entrada de teste: o sensor WSE9(M4)-3 dispõe de uma entrada de teste ("ET" ou "Teste" no esquema de conexões [B]), através da qual é possível verificar o seu funcionamento correto: ao utilizar conectores fêmea com indicadores LED, certificar-se de que a ET tenha o pin-out adequado.

Não pode haver nenhum objeto entre o emissor e o receptor, ativar a entrada de teste (ver o esquema de conexões [B], ET com 0V). O LED de emissão é desligado ou há a simulação, de que um objeto foi detectado. Utilizar os gráficos C e G para verificar o funcionamento. Se a saída de comutação não se comportar de acordo com o gráfico C, verificar as condições de uso. Ver a seção Diagnóstico de erros.

## 36 Dispositivos com características especiais

WSE9M4-3P3410S02: Infravermelho de alta potência, reserva de função aumentada, distância de comutação máx. de 13 m, tamanho do ponto de luz 140 mm (1m de distância), tempo de resposta < 1 ms, frequência de comutação 500 Hz

## 37 Diagnóstico de erros

A tabela I mostra as medidas a serem executadas, quando o sensor não estiver funcionando.

## 38 Tabela Diagnóstico de erros

Indicador LED / padrão de erro / LED indicator/fault pattern	Causa / Cause	Medida / Measures
LED verde apagado / Green LED does not light up	Sem tensão ou tensão abaixo dos valores-limite / No voltage or voltage below the limit values	Verificar a alimentação de tensão, verificar toda a conexão elétrica (cabos e conectores) / Check the power supply, check all electrical connections (cables and plug connections)

Indicador LED / padrão de erro / LED indicator/fault pattern	Causa / Cause	Medida / Measures
LED verde apagado / Green LED does not light up	Interrupções de tensão / Voltage interruptions	Assegurar uma alimentação de tensão estável sem interrupções / Ensure there is a stable power supply without interruptions
LED verde apagado / Green LED does not light up	Sensor está com defeito / Sensor is faulty	Se a alimentação de tensão estiver em ordem, substituir o sensor / If the power supply is OK, replace the sensor
LED verde aceso, sem sinal de saída na detecção de objetos / Green LED lights up, no output signal when object is detected	Entrada de teste (ET) não está conectada corretamente / Test input (TI) is not connected properly	Ver observação relativa à conexão da ET / See the note on connecting the TI
LED amarelo intermitente / Yellow LED flashes	Sensor ainda está operacional, mas as condições de operação não são ideais / Sensor is still ready for operation, but the operating conditions are not ideal	Verificar as condições de operação: Alinhar o feixe de luz (ponto de luz) completamente ao receptor / Limpeza das superfícies ópticas / reajustar a sensibilidade / Verificar e, se necessário, adaptar a distância de comutação, ver gráfico H. / Check the operating conditions: Fully align the beam of light (light spot) with the receiver. / Clean the optical surfaces. / Readjust the sensitivity / Check sensing range and adjust if necessary; see graphic H.
LED amarelo aceso, nenhum objeto no caminho óptico / Yellow LED lights up, no object in the path of the beam	O feixe de luz de uma barreira de luz unidirecional está incidindo sobre o receptor de uma outra barreira de luz unidirecional (vizinha) / The beam of light of a photoelectric through-beam sensor hits the receiver of another (neighboring) photoelectric through-beam sensor	Trocar a disposição do sensor e do receptor a cada duas barreiras de luz unidirecionais ou manter distância suficiente entre as barreira de luz unidirecionais. / Swap the sender and receiver arrangement at every second photoelectric through-beam sensor and ensure that there is sufficient distance between the through-beam photoelectric sensors

## 39 Desmontagem e descarte

O descarte do sensor deve ser efetuado de acordo com as normas aplicáveis específicas de cada país. No âmbito do descarte, deve-se procurar o aproveitamento dos materiais recicláveis contidos (principalmente dos metais nobres).

## 40 Manutenção

Os sensores SICK não requerem manutenção.



---

Recomendamos que se efetue em intervalos regulares

- uma limpeza das superfícies ópticas
- uma verificação das conexões roscadas e dos conectores

Não são permitidas modificações no aparelho.

Sujeito a alterações sem aviso prévio. As propriedades do produto e os dados técnicos especificados não constituem nenhum certificado de garantia.

# Relè fotoelettrico unidirezionale

## Istruzioni per l'uso

### 41 Avvertenze sulla sicurezza

- Prima della messa in funzionamento leggere le istruzioni per l'uso.
- Allacciamento, montaggio e regolazione solo a cura di personale tecnico specializzato.
- Nessun componente di sicurezza ai sensi della direttiva macchine UE.
- UL: Solo per l'utilizzo in applicazioni ai sensi di NFPA 79. Sono disponibili adattatori elencati da UL con cavi di collegamento. Enclosure type 1.
- Alla messa in funzionamento proteggere l'apparecchio dall'umidità e dalla sporcizia.
- Queste istruzioni per l'uso contengono le informazioni che sono necessarie durante il ciclo di vita del sensore fotoelettrico. deTec4 core

### 42 Uso conforme alle prescrizioni

La WSE9(M4)-3 è un relè fotoelettrico unidirezionale a riflessione optoelettronica (di seguito nominato sensore) utilizzato per il rilevamento ottico senza contatto di oggetti, animali e persone. Per il funzionamento sono necessari un emettitore (WS) e un ricevitore (WE). Se viene utilizzata diversamente e in caso di modifiche sul prodotto, decade qualsiasi diritto alla garanzia nei confronti di SICK.

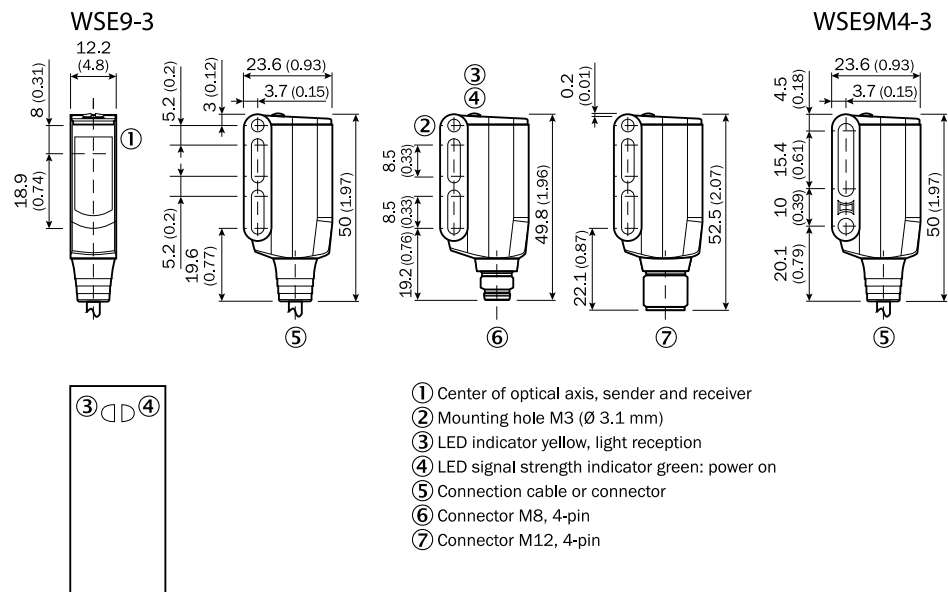

### 43 Messa in funzione

- 1 Rispettare le condizioni d'impiego: predisporre la distanza tra emettitore e ricevitore in base al relativo diagramma (x = distanza di commutazione, y = riserva di funzionamento) [cfr. H].

Se si impiegano diversi sensori fotoelettrici a sbarramento installati uno accanto all'altro, si consiglia di scambiare la disposizione di emettitore e ricevitore di ogni sensore fotoelettrico a sbarramento, ovvero di rispettare una distanza sufficiente fra di essi. In tal modo si possono evitare interferenze reciproche [cfr. F].

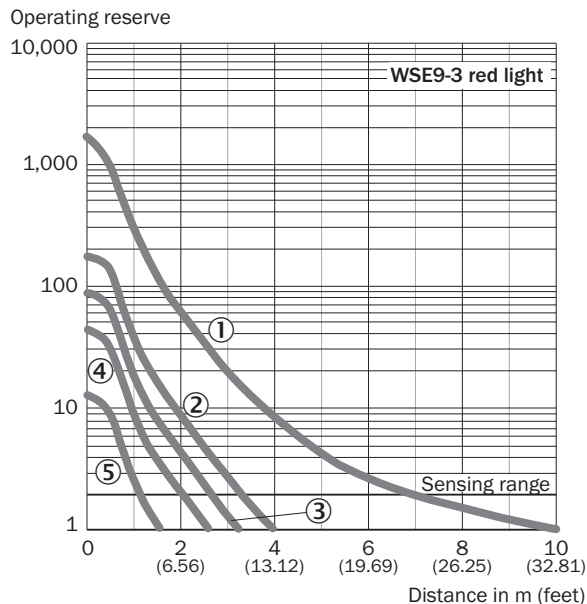

Image: H

- 2 Montare il sensore e il riflettore su dei punti di fissaggio adatti (vedi il programma per accessori SICK). Orientare reciprocamente l'emettitore e il rispettivo ricevitore. Rispettare il momento torcente massimo consentito del sensore di 0.6 Nm.
- 3 Il collegamento dei sensori deve avvenire in assenza di tensione ( $U_V = 0\text{ V}$ ). In base al tipo di collegamento si devono rispettare le informazioni nei grafici [cfr. B]:
  - Collegamento a spina: assegnazione pin
  - Conduttore: colore filo

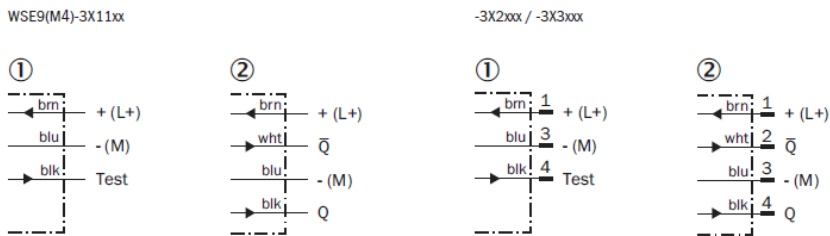

Image: B

Solamente in seguito alla conclusione di tutti i collegamenti elettrici, ripristinare o accendere l'alimentazione di tensione ( $U_V > 0\text{ V}$ ). Sul sensore si accende l'indicatore LED verde.

Spiegazioni dello schema di collegamento (grafico B):

Uscite di commutazione Q ovvero /Q (conformemente al grafico B):

WSE9(M4)-3P (PNP: carico -> M)

WSE9(M4)-3N (NPN: carico -> L+)

TE / test = entrata di prova (vedi funzioni supplementari)

- 4 Orientare l'emettitore sul rispettivo ricevitore. Scegliere la posizione in modo tale che il raggio di luce rosso emesso colpisca il ricevitore. Suggerimento: usare della carta bianca o il riflettore come ausilio per l'orientamento. L'emettitore deve avere una visuale libera sul ricevitore, non ci deve essere nessun oggetto nella traiettoria del raggio [cfr. E]. Fare attenzione affinché le aperture ottiche dei sensori (finestrelle frontali) siano completamente libere.

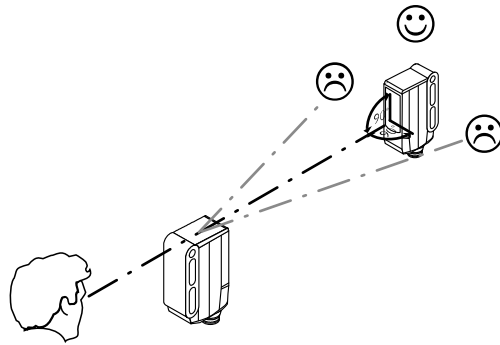

Image: E

- 5 Sensore senza possibilità di impostazione WL9(M4)-3Xxxx0: il sensore è regolato e pronto per il funzionamento.  
 Per verificare il funzionamento, osservare i grafici C e G. Se l'uscita di commutazione non si comporta conformemente al grafico C, verificare le condizioni d'impiego. Vedi paragrafo diagnostica delle anomalie.

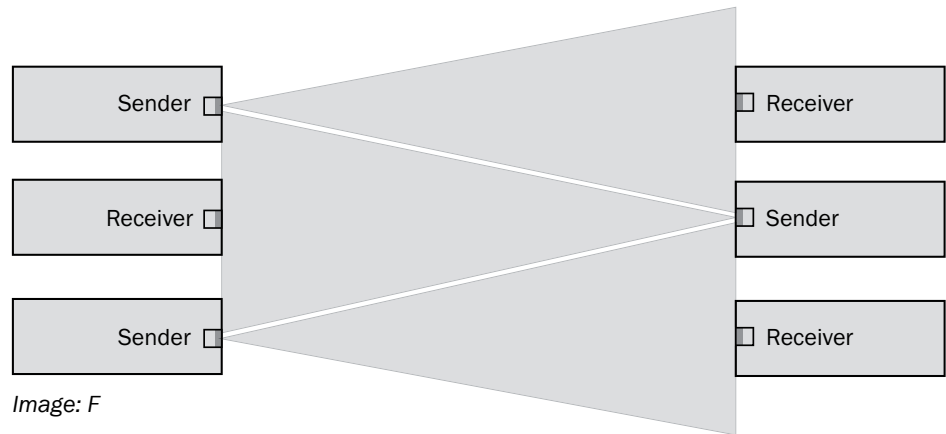

Image: F

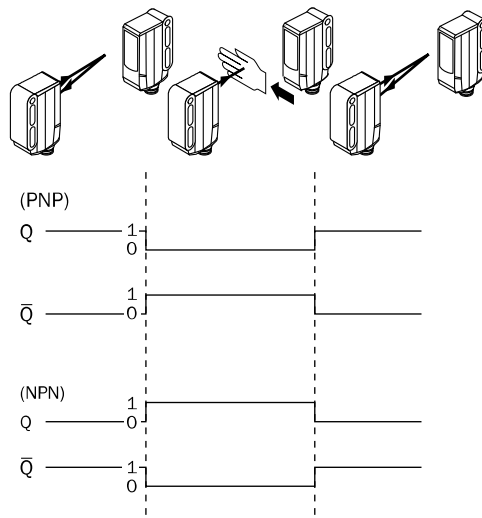

Image: C

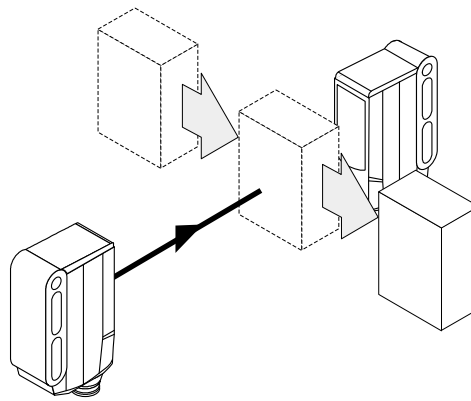

Image: G

## 45 Funzioni supplementari

Entrata di prova: il sensore WSE9(M4)-3 dispone di un'entrata di prova ("TE" o "test" nello schema di collegamento [B]), tramite la quale il funzionamento regolare del sensore può venire controllato: in caso di uso di connettori femmina precablati con indicatori LED si deve prestare attenzione che TE sia relativamente inserita.

Non ci deve essere nessun oggetto tra emettitore e ricevitore, attivare l'entrata di prova (vedi schema di collegamento [B], TE verso 0V). Il LED di emissione si spegne, ovvero viene simulato il rilevamento di un oggetto. Per verificare il funzionamento, osservare i grafici C e G. Se l'uscita di commutazione non si comporta conformemente al grafico C, verificare le condizioni d'impiego. Vedi paragrafo diagnostica delle anomalie.

## 46 Dispositivi con particolari caratteristiche

WSE9M4-3P3410S02: High-Power-IR, innalzamento riserva di funzionamento, distanza di commutazione max. 13 m, dimensioni punto luminoso 140 mm (distanza 1 m), tempo di risposta < 1 ms, frequenza di commutazione 500 Hz

## 47 Diagnostica delle anomalie

La tabella I mostra quali provvedimenti si devono adottare quando il sensore non funziona più.

## 48 Tabella diagnostica delle anomalie

Indicatore LED / figura di errore / LED indicator/fault pattern	Causa / Cause	Provvedimento / Measures
Il LED verde non si accende / Green LED does not light up	nessuna tensione o tensione al di sotto del valore soglia / No voltage or voltage below the limit values	Verificare la tensione di alimentazione e/o il collegamento elettrico / Check the power supply, check all electrical connections (cables and plug connections)
Il LED verde non si accende / Green LED does not light up	Interruzioni di tensione / Voltage interruptions	Assicurarsi che ci sia un'alimentazione di tensione stabile /

Indicatore LED / figura di errore / LED indicator/fault pattern	Causa / Cause	Provvedimento / Measures
		Ensure there is a stable power supply without interruptions
Il LED verde non si accende / Green LED does not light up	Il sensore è guasto / Sensor is faulty	Se l'alimentazione di tensione è regolare, allora chiedere una sostituzione del sensore / If the power supply is OK, replace the sensor
il LED verde si accende, nessun segnale in uscita al momento di rilevamento dell'oggetto / Green LED lights up, no output signal when object is detected	L'entrata di prova (TE) non è collegata correttamente / Test input (TI) is not connected properly	Vedi le indicazioni per il collegamento della TE / See the note on connecting the TI
Il LED giallo lampeggia / Yellow LED flashes	Il sensore è ancora pronto per il funzionamento, ma le condizioni di esercizio non sono ottimali / Sensor is still ready for operation, but the operating conditions are not ideal	Controllare le condizioni di esercizio: Dirigere il raggio di luce (il punto luminoso) completamente sul ricevitore / Pulizia delle superfici ottiche / Sensibilità / controllare la distanza di commutazione e, se necessario, adattarla, vedi grafico H. / Check the operating conditions: Fully align the beam of light (light spot) with the receiver. / Clean the optical surfaces. / Readjust the sensitivity / Check sensing range and adjust if necessary; see graphic H.
il LED giallo si accende, nessun oggetto nella traiettoria del raggio / Yellow LED lights up, no object in the path of the beam	Il fascio di luce dell'emettitore colpisce il ricevitore di un altro relè fotoelettrico unidirezionale (vicino) / The beam of light of a photoelectric through-beam sensor hits the receiver of another (neighboring) photoelectric through-beam sensor	Scambiare la disposizione di emettitore e ricevitore, o rispettare una distanza sufficiente fra i relè fotoelettrici. / Swap the sender and receiver arrangement at every second photoelectric through-beam sensor and ensure that there is sufficient distance between the through-beam photoelectric sensors

## 49 Smontaggio e smaltimento

Lo smaltimento del sensore deve avvenire conformemente alle direttive previste specificatamente dal paese. Per i materiali riciclabili in esso contenuti (in particolare metalli nobili) si auspica un riciclaggio nell'ambito dello smaltimento.

## 50 Manutenzione

I sensori SICK sono esenti da manutenzione.

A intervalli regolari si consiglia di

- pulire le superfici limite ottiche
- Verificare i collegamenti a vite e gli innesti a spina

---

Non è consentito effettuare modifiche agli apparecchi.

Contenuti soggetti a modifiche senza preavviso. Le proprietà del prodotto e le schede tecniche indicate non costituiscono una dichiarazione di garanzia.

# Barrera fotoeléctrica unidireccional

## Instrucciones de uso

### 51 Instrucciones de seguridad

- Lea las instrucciones de uso antes de efectuar la puesta en servicio.
- La conexión, el montaje y el ajuste deben ser efectuados exclusivamente por técnicos especialistas.
- No se trata de un componente de seguridad según la Directiva de máquinas de la UE.
- UL: solo para utilizar en aplicaciones según NFPA 79. Se encuentran disponibles adaptadores listados por UL con cable de conexión. Enclosure type 1.
- Proteja el equipo contra la humedad y la suciedad durante la puesta en servicio.
- Las presentes instrucciones de uso contienen información que puede serle necesaria durante todo el ciclo de vida del sensor.

### 52 Uso conforme a lo previsto

La WSE9(M4)-3 es una barrera optoelectrónica monohaz (en lo sucesivo llamada sensor) empleada para la detección óptica y sin contacto de objetos, animales y personas. Para que funcione se precisa un transmisor (WS) y un receptor (WE). Cualquier uso diferente al previsto o modificación en el producto invalidará la garantía por parte de SICK AG.

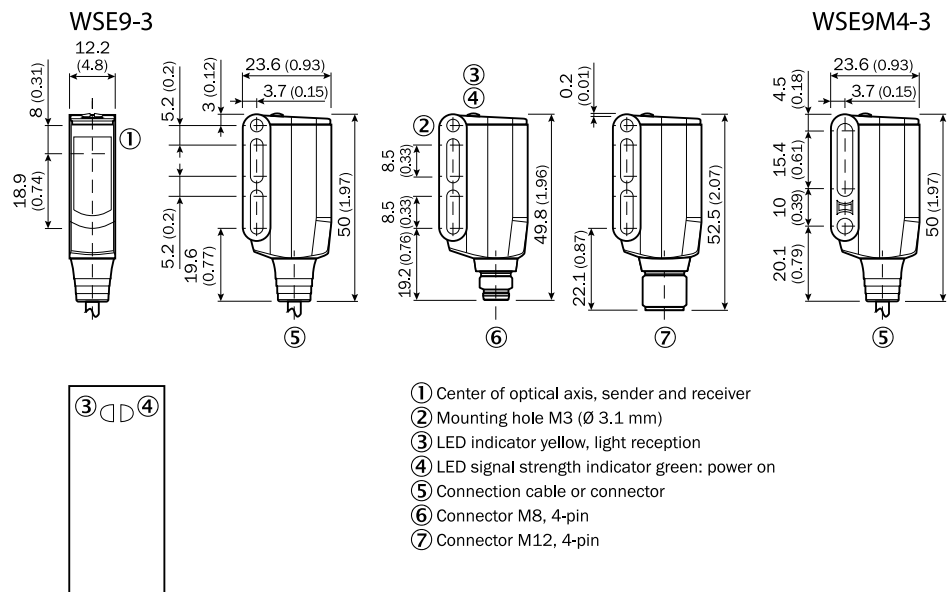

### 53 Puesta en servicio

- 1 Respetar las condiciones de aplicación: comparar la distancia entre el transmisor y el receptor con el diagrama correspondiente [véase fig. H] (x = distancia de conmutación, y = reserva de funcionamiento).



Si se usan varias barreras fotoeléctricas unidireccionales instaladas una al lado de otra, recomendamos cambiar la disposición de transmisores y receptores cada dos barreras, o mantener una distancia suficiente entre ellas. De este modo se evitarán las interferencias mutuas [véase Figura F].

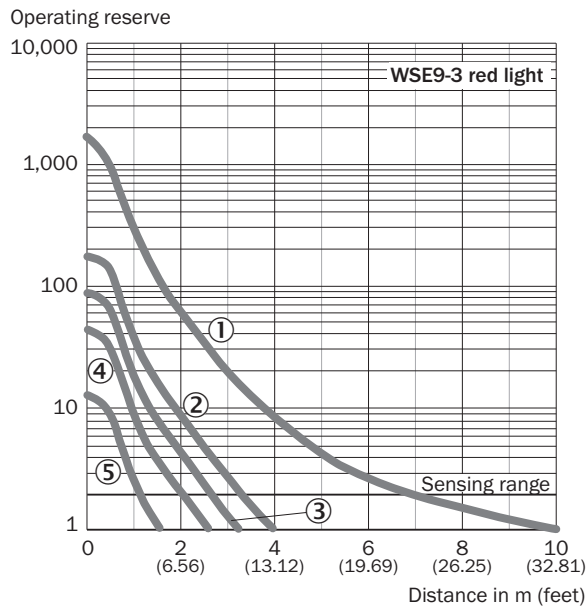

Image: H

- 2 Montar los sensores (transmisores y receptores) en escuadras de fijación adecuadas (véase el programa de accesorios SICK). Alinear el transmisor y el receptor entre sí  
Respetar el par de apriete máximo admisible del sensor de 0.6 Nm.
- 3 Los sensores deben conectarse sin tensión ( $U_V = 0$  V). Debe tenerse en cuenta la información de las figuras [B] en función de cada tipo de conexión:
  - Conexión de enchufes: asignación de pines
  - Cable: color del hilo

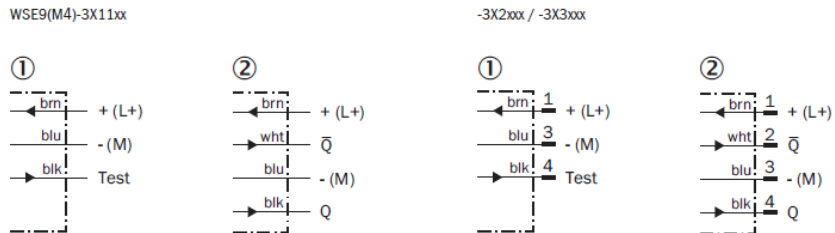

Image: B

No conectar o aplicar la fuente de alimentación ( $U_V > 0$  V) hasta que no se hayan realizado todas las conexiones eléctricas. En el sensor se ilumina el LED indicador verde.

Explicaciones relativas al esquema de conexión (figura B)

Salidas conmutadas Q o  $\bar{Q}$  (según figura B):

WSE9(M4)-3P (PNP: carga -> M)

WSE9(M4)-3N (NPN: carga -> L+)

TE / Test = entrada de prueba (véase Funciones adicionales)

- 4 Oriente el transmisor hacia el receptor Seleccione una posición que permita que el haz de luz roja del transmisor incida en el receptor. Recomendación: utilizar papel blanco o un reflector como ayuda de alineación. El transmisor debe tener una visi-

ón despejada del receptor, no puede haber ningún objeto en la trayectoria del haz [véase Figura E]. Hay que procurar que las aperturas ópticas (pantallas frontales) de los sensores estén completamente libres.

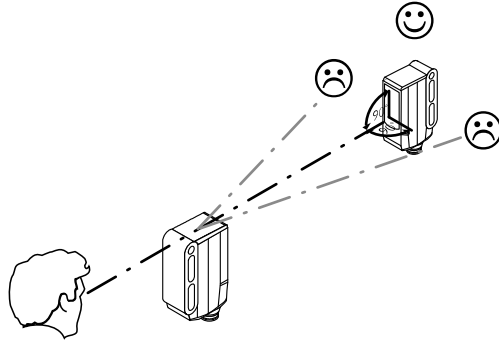

Image: E

- 5 Sensor sin posibilidad de ajuste WL9(M4)-3Xxxx0: el sensor está ajustado y listo para su uso.  
Para verificar el funcionamiento, véanse las figuras C y G. Si la salida conmutada no se comporta según la figura C, comprobar las condiciones de aplicación. Véase la sección "Diagnóstico de fallos".

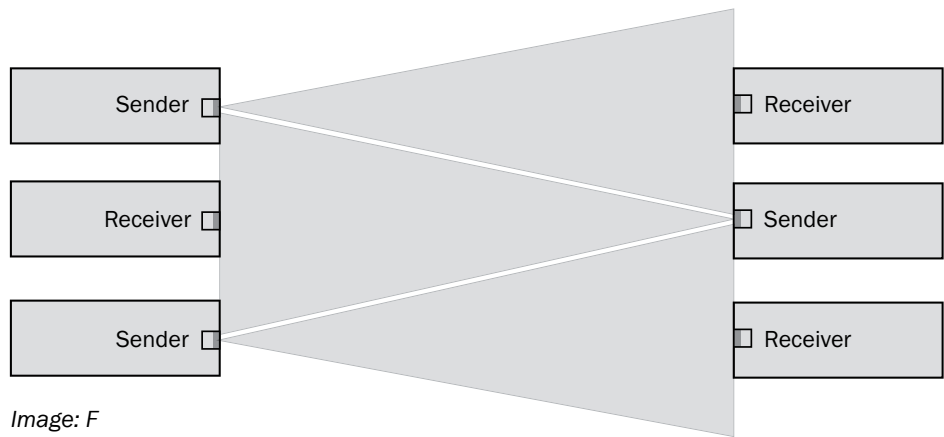

Image: F

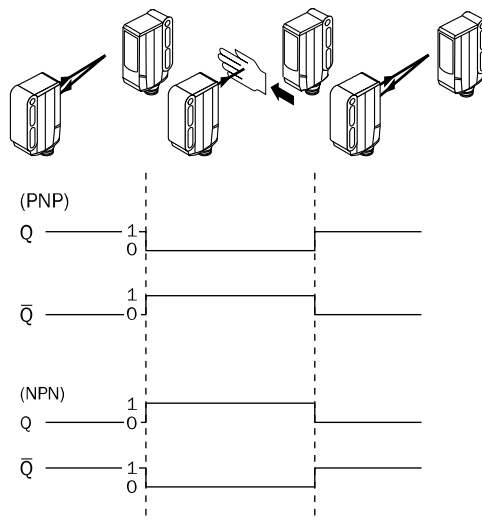

Image: C

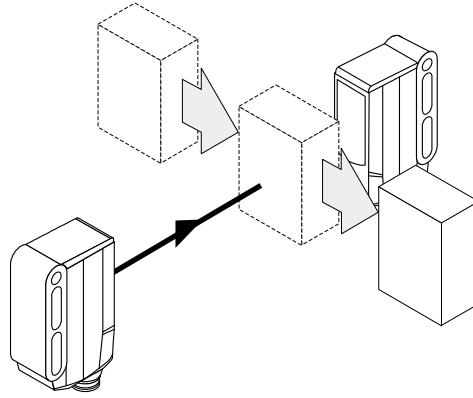

Image: G

## 55 Funciones adicionales

Entrada de prueba: el sensor WSE9(M4)-3 dispone de una entrada de prueba ("TE" o "Test" en el esquema de conexión [B]), con la que puede comprobarse el buen funcionamiento del sensor: si se utilizan tomas de red con indicadores LED hay que procurar que la TE esté asignada como corresponde.

No se puede encontrar ningún objeto entre transmisor y receptor, activar la entrada de prueba (véase esquema de conexión [B], TE tras 0 V). El LED emisor se desconecta o se simula que se ha detectado un objeto. Para verificar el funcionamiento, véanse las figuras C y G. Si la salida conmutada no se comporta según la figura C, comprobar las condiciones de aplicación. Véase la sección "Diagnóstico de fallos".

## 56 Dispositivos con características especiales

WSE9M4-3P3410S02: IR High Power, mayor reserva de funcionamiento, distancia máx. de conmutación 13 m, tamaño del punto de luz 140 mm (a 1 m de distancia), tiempo de respuesta < 1 ms, frecuencia de conmutación 500 Hz

## 57 Diagnóstico de fallos

La tabla I muestra las medidas que hay que tomar cuando ya no está indicado el funcionamiento del sensor.

## 58 Tabla Diagnóstico de fallos

LED indicador / imagen de error / LED indicator/fault pattern	Causa / Cause	Acción / Measures
El LED verde no se ilumina / Green LED does not light up	Sin tensión o tensión por debajo de los valores límite / No voltage or voltage below the limit values	Comprobar la fuente de alimentación, comprobar toda la conexión eléctrica (cables y conectores) / Check the power supply, check all electrical connections (cables and plug connections)

LED indicador / imagen de error / LED indicator/fault pattern	Causa / Cause	Acción / Measures
El LED verde no se ilumina / Green LED does not light up	Interrupciones de tensión / Voltage interruptions	Asegurar una fuente de alimentación estable sin interrupciones de tensión / Ensure there is a stable power supply without interruptions
El LED verde no se ilumina / Green LED does not light up	El sensor está defectuoso / Sensor is faulty	Si la fuente de alimentación no tiene problemas, cambiar el sensor / If the power supply is OK, replace the sensor
El LED verde se ilumina, no hay señal de salida cuando se detecta un objeto / Green LED lights up, no output signal when object is detected	La entrada de prueba (TE) no está correctamente conectada / Test input (TI) is not connected properly	Ver indicaciones para conectar la entrada de prueba (TE) / See the note on connecting the TI
El LED amarillo parpadea / Yellow LED flashes	El sensor aún está operativo, pero las condiciones de servicio no son óptimas / Sensor is still ready for operation, but the operating conditions are not ideal	Comprobar las condiciones de servicio: Alinear el haz de luz (punto de luz) completamente con el receptor / Limpieza de las superficies ópticas / Reajustar la sensibilidad / Comprobar la distancia de conmutación y, si es necesario, adaptarla, véase Figura H. / Check the operating conditions: Fully align the beam of light (light spot) with the receiver. / Clean the optical surfaces. / Readjust the sensitivity / Check sensing range and adjust if necessary; see graphic H.
El LED amarillo se ilumina, no hay ningún objeto en la trayectoria del haz / Yellow LED lights up, no object in the path of the beam	El haz de luz de una barrera fotoeléctrica monohaz incide sobre el receptor de otra barrera fotoeléctrica monohaz (vecina) / The beam of light of a photoelectric through-beam sensor hits the receiver of another (neighboring) photoelectric through-beam sensor	Cada dos barreras fotoeléctricas monohaz, cambiar la disposición de transmisores y receptores o mantener una distancia suficiente entre ellas. / Swap the sender and receiver arrangement at every second photoelectric through-beam sensor and ensure that there is sufficient distance between the through-beam photoelectric sensors

## 59 Desmontaje y eliminación

El sensor tiene que eliminarse siguiendo la normativa aplicable específica de cada país. Los materiales valiosos que contenga (especialmente metales nobles) deben ser eliminados considerando la opción del reciclaje.

## 60 Mantenimiento

Los sensores SICK no precisan mantenimiento.

---

A intervalos regulares, recomendamos:

- Limpiar las superficies ópticas externas
- Comprobar las uniones roscadas y las conexiones.

No se permite realizar modificaciones en los aparatos.

Sujeto a cambio sin previo aviso. Las propiedades y los datos técnicos del producto no suponen ninguna declaración de garantía.

# 对射式光电传感器 操作说明

## 61 安全须知

- 调试前请阅读操作说明。
- 仅允许由专业人员进行接线、安装和设置。
- 本设备非欧盟机械指令中定义的安全部件。
- UL: 仅限用于符合 NFPA 79 的应用。可用 UL 所列出的含连接线缆的连接器。Enclosure type 1.
- 调试前防止设备受潮或污染。
- 本操作说明中包含了传感器生命周期中必需的各项信息。

## 62 拟定用途

WSE9(M4)-3 是一种光电式单向光栅（下文简称为“传感器”），用于物体、动物和人体的非接触式光学检测。须配有一个发射器 (ws) 和一个接收器 (WE) 才可正常运行。如果滥用本产品或擅自更改产品，则 SICK AG 公司所作之质保承诺均将失效。

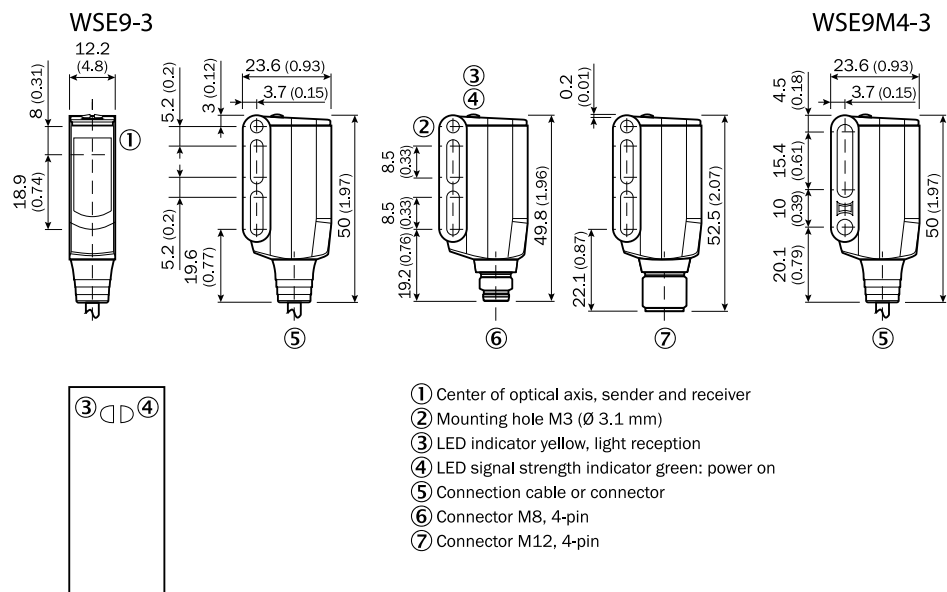

## 63 调试

- 1 注意使用条件：使用随附的图表 [参照 H] 调整发射器和接收器之间的距离（x = 开关距离，y = 信号冗余）。  
使用多个采用相邻方式安装的透射式光电传感器时，我们建议每隔一个透射式光电传感器即交换发射器和接收器的顺序或按规定在各个透射式光电传感器之间保留足够间距。由此可避免相互间的影响 [参照 F]。

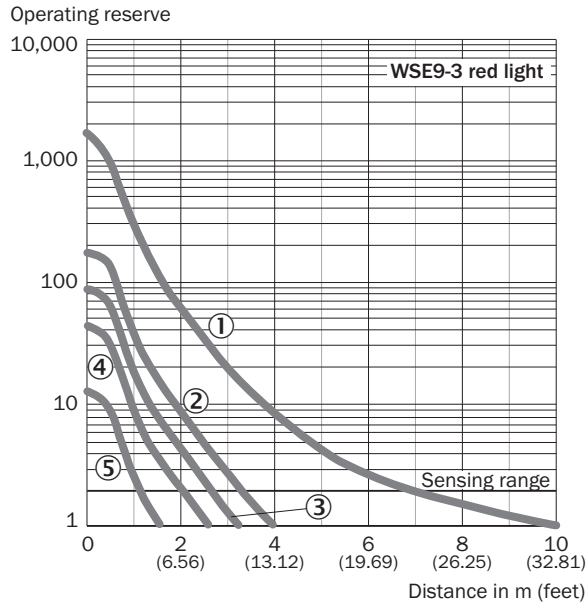

Image: H

- 2 将传感器（反射器和接收器）安装在合适的安装托架上（参见 SICK 附件说明书）。相互对准反射器和接收器。  
注意传感器的最大允许拧紧扭矩为 0.6 Nm。

- 3 必须在无电压状态 ( $U_V = 0\text{ V}$ ) 连接传感器。依据不同连接类型，注意图 [参照 B] 中的信息：

- 插头连接：引线分配
- 导线：芯线颜色

WSE9(M4)-3X11xx

-3X2xxx / -3X3xxx

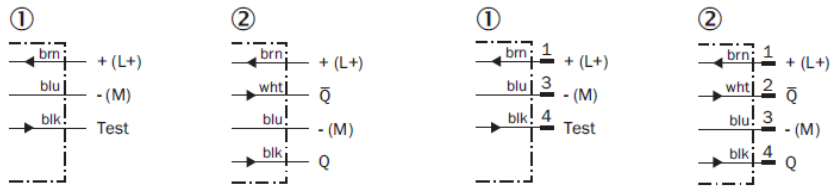

Image: B

完成所有电子连接后，才敷设或接通电源 ( $U_V > 0\text{ V}$ )。传感器上的绿色 LED 指示灯亮起。

接线图（图 B）说明：

开关输出端 Q 或 /Q（根据图 B）：

WSE9(M4)-3P (PNP: 负载 -> M)

WSE9(M4)-3N (NPN: 负载 -> L+)

TE / Test = 测试输入端（参见附加功能）

- 4 将发射器对准接收器。选择定位，确保红色发射光束射中接收器。提示：可使用白纸或反射器作为校准参考。发射器应无遮挡地观察到接收器，光路中不得有任何物体 [参照 E]。此时，应注意传感器的光学开口（前部玻璃）处应无任何遮挡。

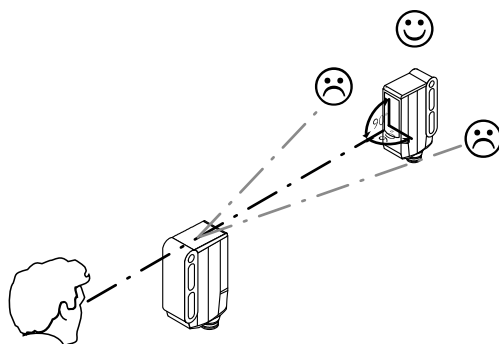

Image: E

- 5 无需设置传感器 WL9(M4)-3Xxxx0: 传感器已设置并准备就绪。参照图 C 和 G 检查功能。如果输出信号开关装置的动作不符合图 C, 则须检查使用条件。参见故障诊断章节。

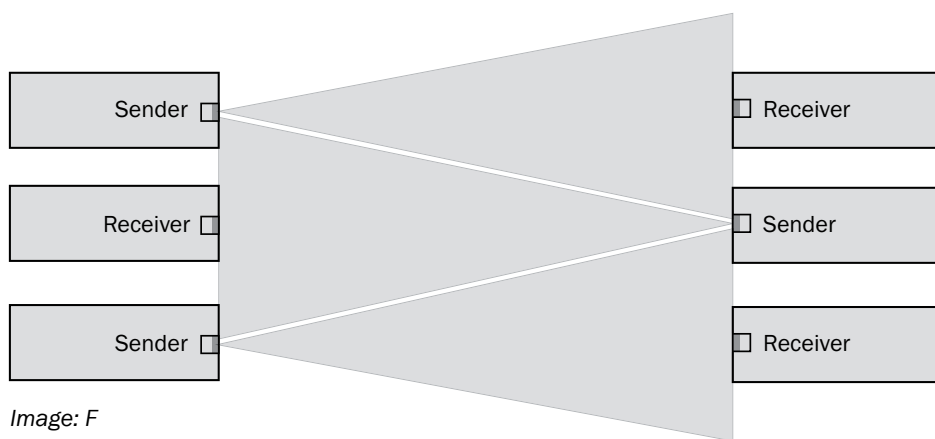

Image: F

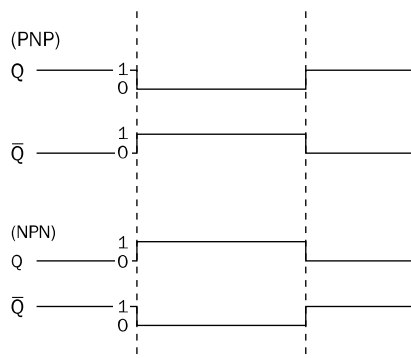
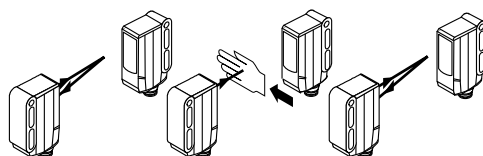
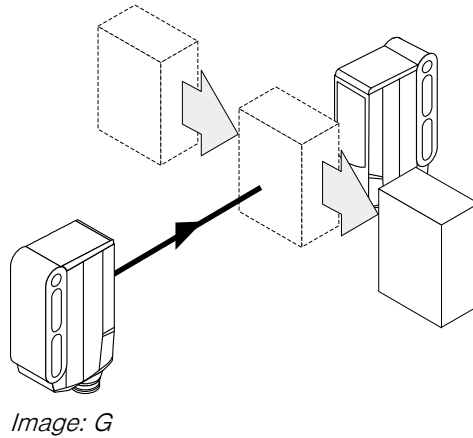

Image: C





## 65 附加功能

测试输入端：传感器 WSE9(M4)-3 具有测试输入功能（接线图 [B] 中的“TE”或者“Test”），使用该输入端检查传感器功能是否正确：使用配备 LED 指示灯的母插头时应注意相应分配 TE。

激活测试输入端时，发送器和接收器之间不得出现任何物体（参见接线图 [B]，TE 为 0V）。关闭或模拟 LED 发送信号，以便识别物体。参照图 C 和 G 检查功能。如果输出信号开关装置的动作不符合图 C，则须检查使用条件。参见故障诊断章节。

## 66 具有特殊功能的设备

WSE9M4-3P3410S02: 高功率 IR, 提高信号冗余, 开关距离最大 13 m, 光点尺寸 140 mm (1m 距离), 响应时间 < 1 ms, 开关频率 500 Hz

## 67 故障诊断

表 I 中罗列了传感器无法执行某项功能时应采取的各项措施。

## 68 表故障诊断

LED 指示灯 / 故障界面 / LED indicator/fault pattern	原因 / Cause	措施 / Measures
绿色 LED 未亮起 / Green LED does not light up	无电压或电压低于极限值 / No voltage or voltage below the limit values	检查电源, 检查整体电气连接 (导线和插头连接) / Check the power supply, check all electrical connections (cables and plug connections)
绿色 LED 未亮起 / Green LED does not light up	电压中断 / Voltage interruptions	确保电源稳定无中断 / Ensure there is a stable power supply without interruptions
绿色 LED 未亮起 / Green LED does not light up	传感器损坏 / Sensor is faulty	如果电源正常, 则更换传感器 / If the power supply is OK, replace the sensor

LED 指示灯 / 故障界面 / LED indicator/fault pattern	原因 / Cause	措施 / Measures
绿色 LED 亮起, 探测物体时无输出信号 / Green LED lights up, no output signal when object is detected	未正确连接测试输入端 (TE) / Test input (TI) is not connected properly	参见 TE 的连接提示 / See the note on connecting the TI
, 黄色 LED 闪烁 / Yellow LED flashes	尽管传感器准备就绪, 但运行条件不佳 / Sensor is still ready for operation, but the operating conditions are not ideal	检查运行条件: 光束 (光斑) 完全对准接收器 / 清洁光学表面 / 重新设置灵敏度 / 检查开关距离, 必要时调整; 参见图 H. / Check the operating conditions: Fully align the beam of light (light spot) with the receiver. / Clean the optical surfaces. / Readjust the sensitivity / Check sensing range and adjust if necessary; see graphic H.
黄色 LED 亮起, 光路中无物体 / Yellow LED lights up, no object in the path of the beam	某个单向光栅的光束照射到另一个 (相邻) 单向光栅的接收器上 / The beam of light of a photoelectric through-beam sensor hits the receiver of another (neighboring) photoelectric through-beam sensor	每隔一个单向光栅即交换发射器和接收器的顺序或在各个单向光栅之间保留足够间距。 / Swap the sender and receiver arrangement at every second photoelectric through-beam sensor and ensure that there is sufficient distance between the through-beam photoelectric sensors

## 69 拆卸和废弃处理

必须根据当地特定的法律法规废弃处理传感器。如果其中含有可回收材料 (尤其是贵金属), 则必须在废弃处理时回收利用。

## 70 保养

SICK 传感器无需保养。

我们建议, 定期:

- 清洁镜头检测面
- 检查螺栓连接和插头连接

不得对设备进行任何改装。

如有更改, 不另行通知。所给出的产品特性和技术参数并非质保声明。

# 透過形光電センサ 取扱説明書

## 71 安全上の注意事項

- ご使用前に必ず取扱説明書をお読みください。
- 本製品の接続・取り付け・設定は、訓練を受けた技術者が行って下さい。
- 本製品は EU 機械指令の要件を満たす安全コンポーネントではありません。
- UL : NFPA79 に準拠した用途においてのみご使用ください。UL 規格によってリストアップされた接続ケーブル付きのアダプターを使用できます。Enclosure type 1.
- 使用開始前に、湿気や汚れから機器を保護して下さい。
- 本取扱説明書には、センサのライフサイクル中に必要となる情報が記載されています。

## 72 正しいご使用方法

WSE9(M4)-3 は透過形光電センサ（以下「センサ」）で、物体、動物または人などを光学的技術により非接触で検知するための装置です。操作には投光器（WS）および受光器（WE）が必要です。本製品が本来の使用用途以外の目的に使用されたり、何らかの方法で改造された場合、SICK AG に対するいかなる保証要求も無効になります。

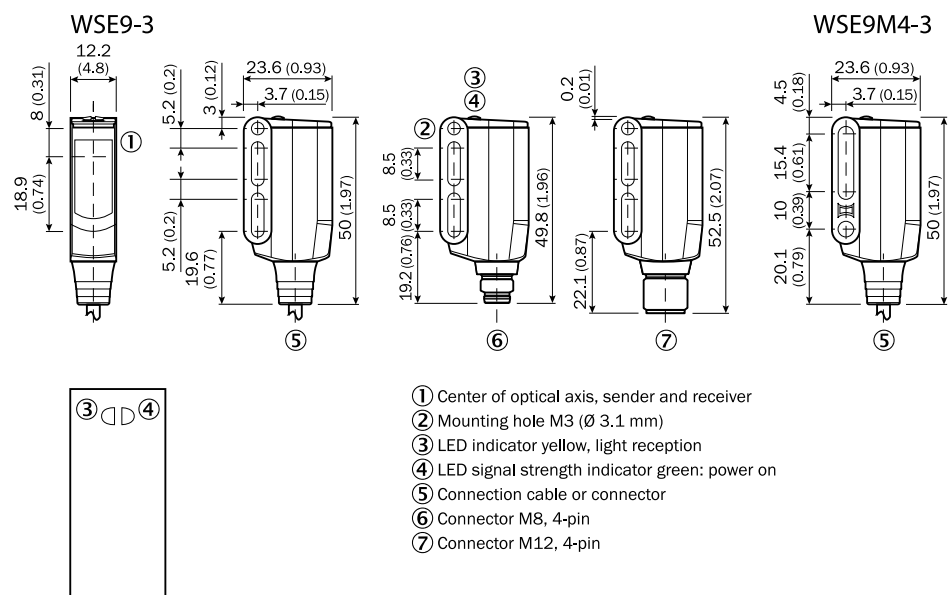

## 73 使用開始

- 1 使用条件に注意します: 投光器と受光器の間隔を対応する図 [H を参照] に従って調整します (x = 検出距離、y = 機能リザーブ)。  
複数の透過形光電センサを隣り合わせに取り付けて使用する場合、透過形光電センサひとつおきに投光器と受光器の配置を入れ替え、透過形光電センサの間に十分な間隔を保つことをお勧めします。それにより相互干渉を防止することができます [F を参照]。

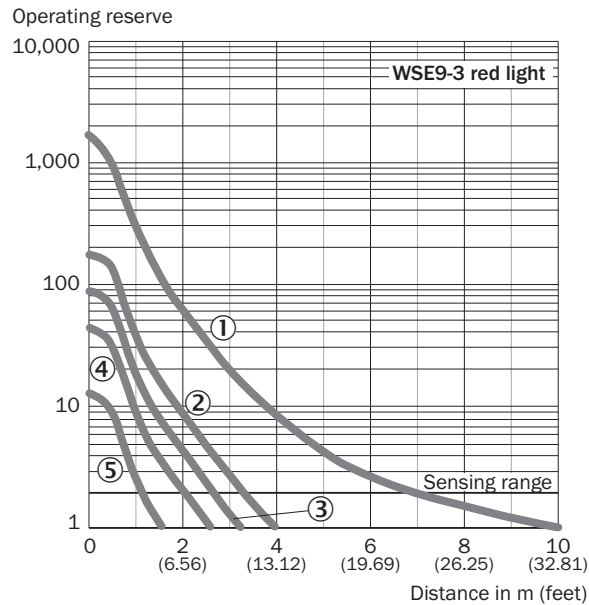

Image: H

- 2 適切なブラケットを使用してセンサ（投光器と受光器）を取り付けます（SICK 付属品カタログを参照）。投光器と受光器を互いに方向調整します。センサの締め付けトルクの最大許容値 0.6 Nm に注意してください。
- 3 センサの接続は必ず無電圧状態 ( $U_V = 0\text{ V}$ ) で行ってください。接続タイプに応じて、図 [B] の情報に注意する必要があります：
  - オスコネクタ接続：ピン割り当て
  - ケーブル：芯の色

WSE9(M4)-3X11xx

-3X2xxx / -3X3xxx

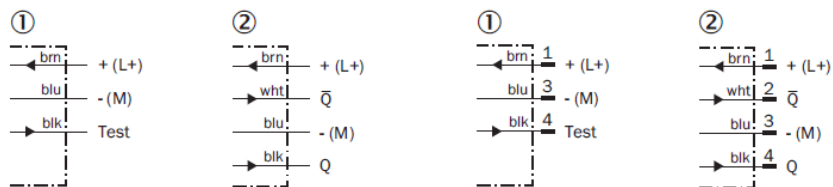

Image: B

まずすべての電気接続を確立してから、電源 ( $U_V > 0\text{ V}$ ) をオンにしてください。緑色の LED 表示灯がセンサ上で点灯します。

接続図の説明（図 B）。

スイッチング出力 Q および /Q（図 B に準拠）：

WSE9(M4)-3P（PNP：負荷 → M）

WSE9(M4)-3N（NPN：負荷 → L+）

TE / テスト = テスト入力（追加機能参照）

- 4 投光器を受光器に位置合わせします。赤色の投光軸が受光器に照射されるように、位置を選択します。ヒント：白紙またはリフレクタを方向調整の補助手段として使ってください。センサでの読み取りを可能にするため、受光器が遮らざられたり、照射経路に対象物があつたりしてはなりません [E を参照]。センサの光開口部（フロントスクリーン）が全く遮られないよう、注意してください。

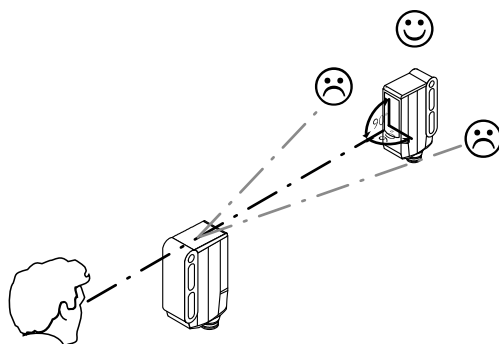

Image: E

- 5 設定不要なセンサ WL9(M4)-3Xxxx0: センサは設定され、動作準備が整っています。

機能を点検するために、グラフ C および G を使用します。スイッチング出力がグラフ C に従った動作を示さない場合は、使用条件を点検してください。故障診断の章を参照。

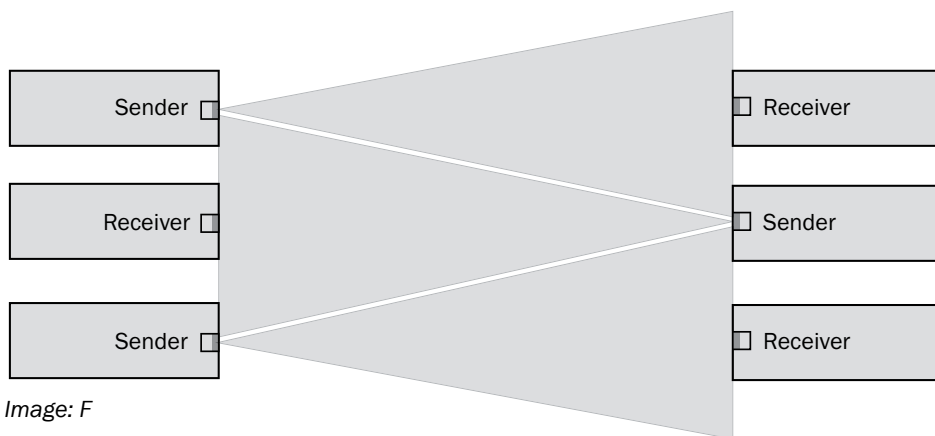

Image: F

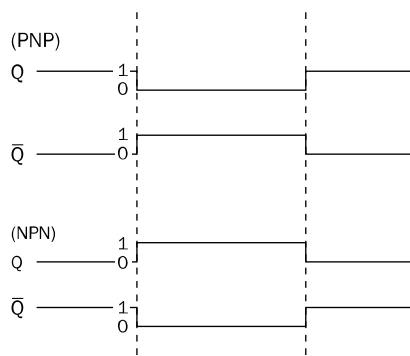
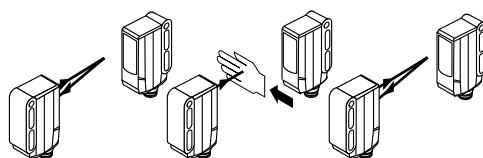
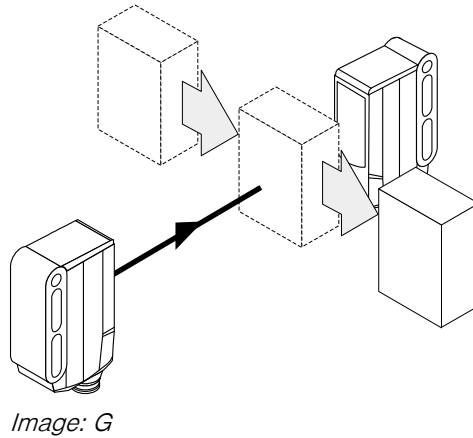

Image: C



## 75 追加機能

テスト入力: センサ WSE9(M4)-3 にはテスト入力（概略接続図 [B] の「TE」または「テスト」）が付いており、これによってセンサーが正しく機能しているかどうかを検査できます。LED 表示灯付きのケーブルソケットを使用する場合は、TE が適切に配置されているかどうか注意してください。

投光器と受光器の間に対象物があってはなりません。テスト入力を有効にします（概略接続図 [B] を参照、0V に従った TE）。投光 LED がオフになるか、または対象物の検出がシミュレーションされます。機能を点検するために、グラフ C および G を使用します。スイッチング出力がグラフ C に従った動作を示さない場合は、使用条件を点検してください。故障診断の章を参照。

## 76 特別な特徴を持つ機器

WSE9M4-3P3410S02: ハイパワー IR、向上した動作余裕度、検出距離 最大 13 m、光点サイズ 140 mm (1m の距離)、応答時間 < 1 ms、スイッチング周波数 500 Hz

## 77 故障診断

表 1 は、センサが機能しなくなった場合に、どのような対策を講じるべきかを示しています。

## 78 表エラー診断

LED 表示灯/故障パターン / LED indicator/fault pattern	原因 / Cause	対策 / Acción
緑色の LED が点灯しない / Green LED does not light up	無電圧、または電圧が限界 値以下 / No voltage or voltage be- low the limit values	電源を確認し、すべての電 気接続（ケーブルおよびプ ラグ接続）を確認します / Check the power supply, check all electrical connec- tions (cables and plug con- nections)
緑色の LED が点灯しない / Green LED does not light up	電圧がきていない又は不安 定 / Voltage interruptions	安定した電源電圧が供給さ れていることを確認します /

LED 表示灯/故障パターン / LED indicator/fault pattern	原因 / Cause	対策 / Acción
		Ensure there is a stable power supply without interruptions
緑色の LED が点灯しない / Green LED does not light up	センサの異常 / Sensor is faulty	電源に問題がなければ、センサを交換します / If the power supply is OK, replace the sensor
緑色の LED が点灯、対象物が検出された際に出力信号がない / Green LED lights up, no output signal when object is detected	テスト入力 (TI) が正しく接続されていない / Test input (TI) is not connected properly	TI の接続に関する注意事項を参照してください / See the note on connecting the TI
黄色い LED が点滅 / Yellow LED flashes	センサの動作準備はまだ整っているが、動作条件が最適ではない / Sensor is still ready for operation, but the operating conditions are not ideal	動作条件を確認します：投光光軸（投光スポット）が受光器の受光部分に当たるようにします / 光学面の洗浄 / 感度を再調整する / 検出距離を点検し必要に応じて調整する、グラフ H 参照。 / Check the operating conditions: Fully align the beam of light (light spot) with the receiver. / Clean the optical surfaces. / Readjust the sensitivity / Check sensing range and adjust if necessary; see graphic H.
黄色い LED が点灯、光軸に対象物がない / Yellow LED lights up, no object in the path of the beam	透過形光電センサの投光光軸が、別の（隣接する）透過形光電センサの受光器にあたる / The beam of light of a photoelectric through-beam sensor hits the receiver of another (neighboring) photoelectric through-beam sensor	透過形光電センサひとつおきに、投光器と受光器の配置を入れ替え、透過形光電センサ同士の間には十分な間隔を空けます / Swap the sender and receiver arrangement at every second photoelectric through-beam sensor and ensure that there is sufficient distance between the through-beam photoelectric sensors

## 79 解体および廃棄

センサは必ず該当国の規制にしたがって処分してください。廃棄処理の際には、できるだけ構成材料をリサイクルするよう努めてください（特に貴金属類）。

## 80 メンテナンス

SICK センサはメンテナンスフリーです。

定期的に以下を行うことをお勧めしています：

- レンズ境界面の清掃
- ネジ締結と差込み締結の点検

---

機器を改造することは禁止されています。

記載内容につきましては予告なしに変更する場合がございますのであらかじめご了承ください。指定された製品特性および技術データは保証書ではありません。



# Однолучевой фоторелейный барьер

## Руководство по эксплуатации

### 81 Указания по безопасности

- Перед вводом в эксплуатацию изучите руководство по эксплуатации.
- Подключение, монтаж и установку поручать только специалистам.
- Не является оборудованием для обеспечения безопасности в соответствии с Директивой ЕС по работе с машинным оборудованием.
- UL: Только для использования в областях применения согласно NFPA 79. Доступны адаптеры с соединительными кабелями, перечисленные UL. Enclosure type 1.
- При вводе в эксплуатацию защищать устройство от попадания грязи и влаги.
- Данное руководство по эксплуатации содержит информацию, которая необходима во время всего жизненного цикла сенсора.

### 82 Использование по назначению

WSE9(M4)-3 является оптоэлектронным однолучевым световым барьером (в дальнейшем называемым "сенсор") и используется для оптической бесконтактной регистрации вещей, животных и людей. Для эксплуатации необходимы передатчик (WS) и приемник (WE). При ином использовании и при внесении изменений в изделие подача любых гарантийных претензий к SICK AG исключена.

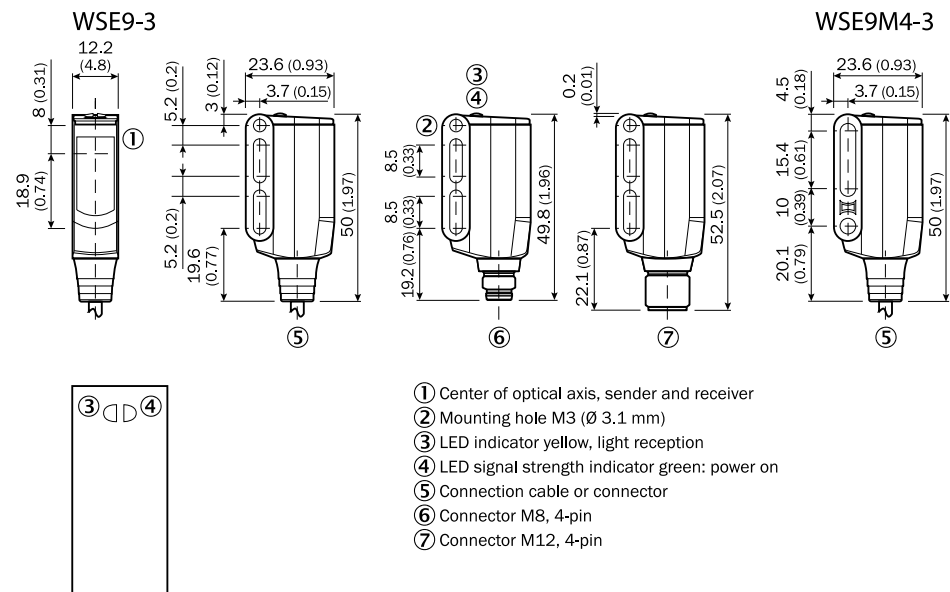

### 83 Ввод в эксплуатацию

1. Учет условий применения: скорректировать дистанцию между сенсором и отражателем с помощью соответствующей диаграммы [см. Н] (x = дистанция переключения, y = функциональный резерв).  
При применении нескольких однолучевых фоторелейных барьеров, которые устанавливаются рядом друг с другом, рекомендуется поменять местами передатчик и приемник каждого второго однолучевого фоторелейного барьера

или же выдержать достаточное расстояние между однолучевыми фоторелейными барьерами. Таким образом можно избежать взаимного воздействия [см. F].

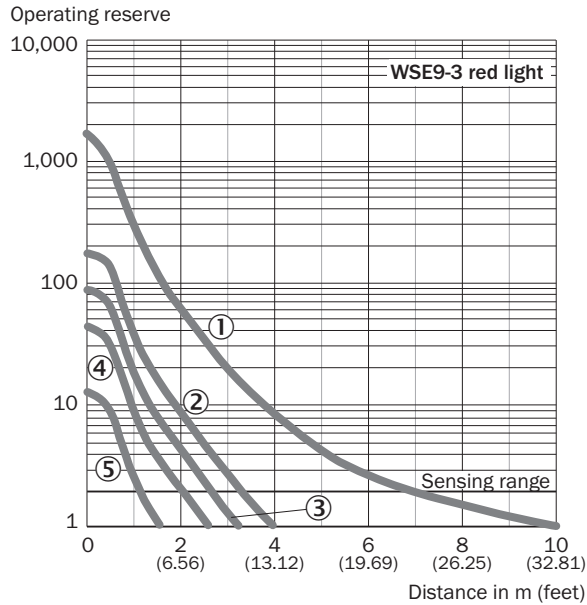

Image: H

- 2 Установите сенсоры (передатчик и приемник) на подходящем крепежном уголке (см. программу принадлежностей от SICK). Выровняйте передатчик и приемник друг относительно друга. Выдерживайте максимально допустимый момент затяжки сенсора в 0.6 Нм.
- 3 Подключайте сенсоры при отключенном напряжении питания ( $U_V = 0\text{ В}$ ). В зависимости от типа подключения следует принять во внимание информацию с графиков [см. B]:
  - Штекерный разъем: назначение контактов
  - Проводник: цвет жилы

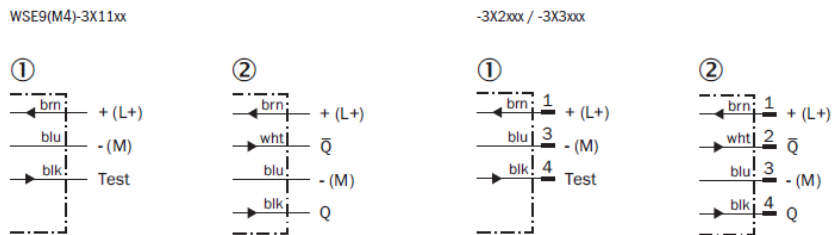

Image: B

Подавайте и включайте напряжение питания только после завершения подключения всех электрических соединений ( $U_V > 0\text{ В}$ ). На сенсоре включается зеленый светодиодный индикатор.

Пояснения к схеме электрических соединений (график B):

Коммутирующие выходы Q или /Q (согласно графику B):

WSE9(M4)-3P (PNP: нагрузка -> M)

WSE9(M4)-3N (NPN: нагрузка -> L+)

TE / Test = тестовый вход (см. дополнительные функции)

- 4 Направьте сенсор на приемник. Выберите такую позицию, чтобы красный луч передатчика попадал на приемник. Совет: в качестве приспособления для выравнивания используйте лист белой бумаги или отражатель. Передатчик

должен иметь свободную траекторию до приемника, нахождение объектов на пути луча не допускается [см. E]. Оптические отверстия (фронтальное стекло) на сенсорах должны быть полностью свободными.

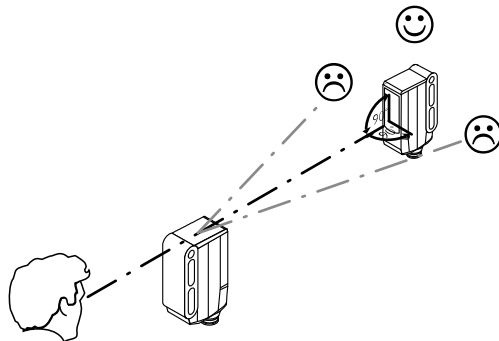

Image: E

- 5 Сенсор без регулировки WL9(M4)-3Xxxx0: сенсор настроен и готов к эксплуатации.

Для проверки функционирования воспользуйтесь графиками С и G. Если характер поведения коммутирующего выхода не соответствует графику С, проверить условия применения. См. раздел "Диагностика неисправностей".

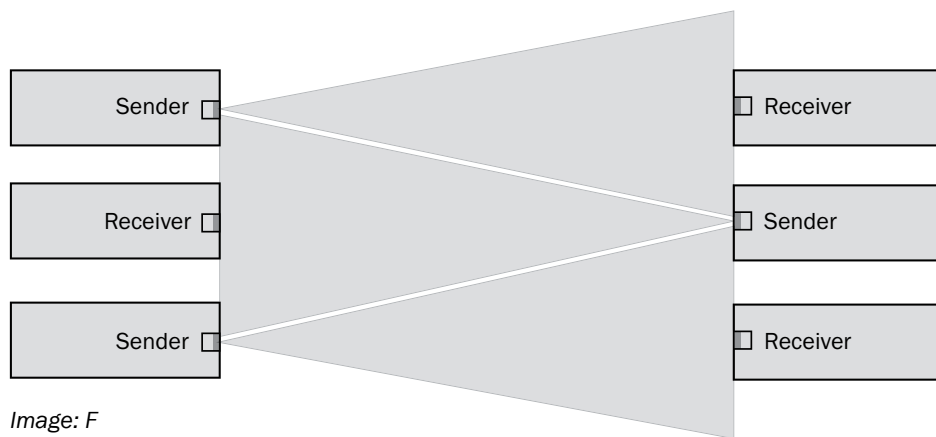

Image: F

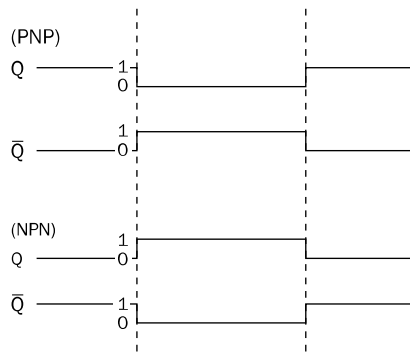
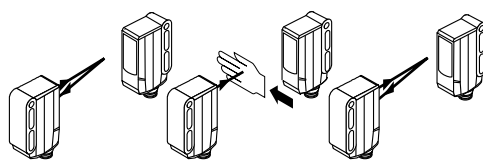
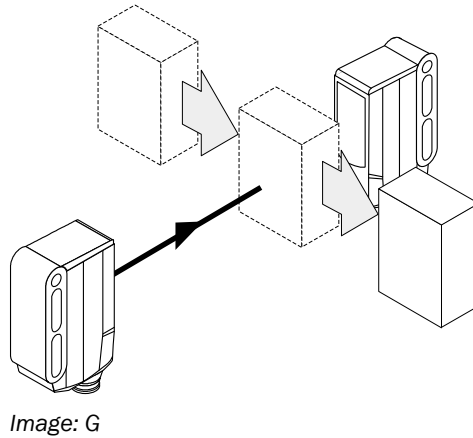

Image: C



## 85 Дополнительные функции

Тестовый вход: сенсор WSE9(M4)-3 имеет тестовый вход („TE“ или „Test“ на схеме электрических соединений [B]), с помощью которого можно проверить надлежащее функционирования сенсора: при использовании розеток со светодиодными индикаторами следите за правильным подключением TE.

Объектов между передатчиком и приемником быть не должно, активируйте тестовый вход (см. схему электрических соединений [B], TE по 0 В). Светодиод передатчика отключается или моделируется распознавание объекта. Для проверки функционирования воспользуйтесь графиками С и G. Если характер поведения коммутирующего выхода не соответствует графику С, проверить условия применения. См. раздел "Диагностика неисправностей".

## 86 Устройства с особыми свойствами

WSE9M4-3P3410S02: High-Power-IR, увеличенный функциональный резерв, расстояние срабатывания макс. 13 м, размер светового пятна 140 мм (на расстоянии 1 м), время отклика < 1 мс, частота переключения 500 Гц

## 87 Диагностика неисправностей

В таблице I показано, какие меры нужно предпринять, если сенсоры не работают.

## 88 таблицы диагностики неисправностей

Светодиодный индикатор / картина неисправности / LED indicator/fault pattern	Причина / Cause	Меры по устранению / Measures
зеленый светодиод не горит / Green LED does not light up	нет напряжения питания или оно ниже нижнего предельного значения / No voltage or voltage below the limit values	Проверить напряжения питания, всю схему электроподключения (проводку и разъемные соединения) / Check the power supply, check all electrical connections (cables and plug connections)

Светодиодный индикатор / картина неисправности / LED indicator/fault pattern	Причина / Cause	Меры по устранению / Measures
зеленый светодиод не горит / Green LED does not light up	Пропадание напряжения питания / Voltage interruptions	Обеспечить надежную подачу напряжения питания без его пропадания / Ensure there is a stable power supply without interruptions
зеленый светодиод не горит / Green LED does not light up	Сенсор неисправен / Sensor is faulty	Если напряжение питания в порядке, то заменить сенсор / If the power supply is OK, replace the sensor
зеленый светодиод горит, выходной сигнал детектирования объекта отсутствует / Green LED lights up, no output signal when object is detected	Тестовый вход (TE) неверно подключен / Test input (TI) is not connected properly	См. указания по подключению TE / See the note on connecting the TI
желтый светодиод мигает / Yellow LED flashes	Сенсор пока еще готов к работе, но эксплуатационные условия не оптимальны / Sensor is still ready for operation, but the operating conditions are not ideal	Проверка эксплуатационных условий: Полностью сориентировать световой луч (световое пятно) на приемник / чистка оптических поверхностей / заново настроить чувствительность / проверить и, при необходимости, скорректировать расстояние срабатывания, см. график Н. / Check the operating conditions: Fully align the beam of light (light spot) with the receiver. / Clean the optical surfaces. / Readjust the sensitivity / Check sensing range and adjust if necessary; see graphic H.
желтый светодиод горит, объект на пути луча отсутствует / Yellow LED lights up, no object in the path of the beam	Световой луч однолучевого фоторелейного барьера попадает на приемник другого (соседнего) однолучевого фоторелейного барьера / The beam of light of a photoelectric through-beam sensor hits the receiver of another (neighboring) photoelectric through-beam sensor	На каждом втором однолучевом фоторелейном барьере поменять местами передатчик и приемник каждого второго однолучевого фоторелейного барьера или же выдержать достаточное расстояние между однолучевыми фоторелейными барьерами. / Swap the sender and receiver arrangement at every second photoelectric through-beam sensor and ensure that there is sufficient distance between the through-beam photoelectric sensors

## 89 Демонтаж и утилизация

Утилизацию сенсоров следует проводить согласно национальным предписаниям по утилизации. Следует стремиться к повторному использованию содержащихся в них материалов (прежде всего, драгоценных металлов).

## 90 Техобслуживание

Датчики SICK не нуждаются в техобслуживании.

Рекомендуется регулярно

- очищать оптические ограничивающие поверхности
- проверять прочность резьбовых и штекерных соединений

Запрещается вносить изменения в устройства.

Право на ошибки и внесение изменений сохранено. Указанные свойства изделия и технические характеристики не являются гарантией.

Sensing range	Schaltabstand	Distance de commutation	Distância de comutação	Distanza di commutazione	Distancia de conmutación	开关距离	検出範囲	Расстояние срабатывания	0 ... 7 m
Sensing range max.	Schaltabstand max.	Portée max.	Distância de comutação máx.	Distanza max. di commutazione	Distancia de conmutación máx.	最大开关距离	最大検出範囲	Расстояние срабатывания, макс.	0 ...10 m <sup>4)</sup>
Light spot diameter/distance	Lichtflekdurchmesser/Entfernung	Diamètre spot / distance	Diâmetro do ponto de luz/ distância	Diámetro punto luminoso/ distancia	Diámetro del punto luminoso/ distancia	光斑直径/ 距离	光点のスポット径/ 距離	Диаметр светового пятна/ расстояние	25 mm / 1 m
Supply voltage V <sub>S</sub>	Versorgungsspannung U <sub>V</sub>	Tension d'alimentation U <sub>V</sub>	Tensão de alimentação U <sub>V</sub>	Tensione di alimentazione U <sub>V</sub>	Tensión de alimentación U <sub>V</sub>	供电电压 U <sub>V</sub>	供給電圧 U <sub>V</sub>	Напряжение питания U <sub>V</sub>	DC 10 ... 30 V <sup>2)</sup>
Output current I <sub>max.</sub>	Ausgangsstrom I <sub>max.</sub>	Courant de sortie I <sub>max.</sub>	Corrente de saída I <sub>max.</sub>	Corrente di uscita I <sub>max.</sub>	Intensidad de salida I <sub>max.</sub>	输出电流 I <sub>max.</sub>	出力電流 I <sub>max.</sub>	Выходной ток I <sub>макс.</sub>	≤ 100 mA
Max. switching frequency	Schaltfolge max.	Commutation max.	Sequência máx. de comutação	Sequenza di commutazione max.	Secuencia de conmutación máx.	最大开关操作顺序	最大スイッチング周波数	Частота срабатывания макс.	1,000 Hz <sup>3)</sup>
Max. response time	Ansprechzeit max.	Temps de réponse max.	Tempo máx. de resposta	Tempo di reazione max.	Tiempo de respuesta máx.	最长响应时间	最大応答時間	Время отклика макс.	< 0.5 ms <sup>4)</sup>
Enclosure rating	Schutzart	Indice de protection	Tipo de proteção	Tipo di protezione	Tipo de protección	防护类型	保護等級	Класс защиты	IP66,IP67, IP69K
Protection class	Schutzklasse	Classe de protection	Classe de proteção	Classe di protezione	Clase de protección	防护等级	保護クラス	Класс защиты	III
Circuit protection	Schutzschaltungen	Protecti- ons électri- ques	Circuitos de proteção	Commutazioni di protezione	Circuitos de protec- ción	保护电路	回路保護	Схемы защиты	A,B,C <sup>5)</sup>

Ambient operating temperature	Betriebsumgebungstemperatur	Température de service	Temperatura ambiente de funcionamiento	Temperatura ambiente di funzionamento	Temperatura ambiente de servicio	工作环境温度	周辺温度 (作動中)	Диапазон рабочих температур	-40 ... +60 °C
<p>1) Object with 90 % remission (based on standard white DIN 5033)</p> <p>2) Limit value: operation in short-circuit protection mains max. 8 A; residual ripple max. 5 Vss</p> <p>3) With light / dark ratio 1:1</p> <p>4) Signal transit time with resistive load</p> <p>5) A = UV-connections reverse polarity protected</p> <p>B = inputs and output reverse-polarity protected</p> <p>C = Interference suppression</p>	<p>1) Tastgut mit 90 % Remission (bezogen auf Standard-Weiß DIN 5033)</p> <p>2) Grenzwerte: Betrieb im kurzschlussgeschützten Netz max. 8 A; Restwelligkeit max. 5 Vss</p> <p>3) Mit Hell- / Dunkelverhältnis 1:1</p> <p>4) Signallaufzeit bei ohmscher Last</p> <p>5) A = UV-Anschlüsse verpolsicher</p> <p>B = Ein- und Ausgänge verpolsicher</p> <p>C = Störimpulsunterdrückung</p>	<p>1) Objet avec 90 % de réémission (par rapport au blanc standard selon DIN 5033)</p> <p>2) Valeurs limites : fonctionnement sur réseau protégé contre les courts-circuits max. 8 A ; ondulation résiduelle max. 5 Vcc</p> <p>3) Pour un rapport clair/sombre de 1:1</p> <p>4) Temps de propagation du signal sur charge ohmique</p> <p>5) A = raccorde-ments UV protégés contre les inversions de polarité</p> <p>B = entrées et sorties protégées contre les inversions de polarité</p> <p>C = Suppression des impulsions parasites</p>	<p>1) Objeto a ser detectado com 90% de luminância (com base no padrão branco DIN 5033)</p> <p>2) Valores limite: funcionamento in rede protegida contra cortocircuito max. 8 A; ondulação residual máx. 5 Vss</p> <p>3) Com proporção sombra/luz 1:1</p> <p>4) Tempo de funcionamento do sinal com carga ôhmica</p> <p>5) A = conexões protegidas contra inversão de pólos UV</p> <p>B = Entradas e saídas protegidas contra polaridade inversa</p> <p>C = Supressão de impulsos parasitas</p>	<p>1) Oggetto con il 90% di remissione (riferito al bianco standard DIN 5033)</p> <p>2) Valori limite: funzionamento in rete protetta da cortocircuito max. 8 A; ondula-zione residua max. 5 Vss</p> <p>3) Con rapporto chiaro / scuro 1:1</p> <p>4) Durata segnale con carico ohmico</p> <p>5) A = UV-Allacciamenti protetti dall'inversione di polarità</p> <p>B = entrate e uscite protette da polarità inversa</p> <p>C = Soppressione impulsi di disturbo</p>	<p>1) Material con un 90% de reflexión (sobre el blanco estándar DIN 5033)</p> <p>2) Valores límite: funcionamiento en red protegida contra cortocircuitos máx. 8 A; ondulación residual máx. 5 Vss</p> <p>3) Con una relación claro/oscuro de 1:1</p> <p>4) Duración de la señal con carga ôhmica</p> <p>5) Conexiones A = UV protegidas contra polarización inversa</p> <p>B = Entradas y salidas protegidas contra polarización incorrecta</p> <p>C = Supresión de impulsos parásitos</p>	<p>1) 具有 90 % 反射比的扫描对象 (指 DIN 5033 规定的标准白)</p> <p>2) 极限值: 在防短路电网中运行, 最大 8 A ; 最大余波 5 Vss</p> <p>3) 明暗比为 1:1</p> <p>4) 信号传输时间 (电阻负载时)</p> <p>5) A = UV 接口 (已采取反极性保护措施)</p> <p>B = 具有反极性保护的输入端和输出端</p> <p>C = 抑制干扰脉冲</p>	<p>1) 反射率 90 % の対象物 (DIN 5033 に準拠した白色)</p> <p>2) 限界値: 短絡保護の操作は最大 8 A ; 残留リップルは最大 5 Vss</p> <p>3) ライト/ダークの比率 1:1</p> <p>4) 負荷のある信号経過時間</p> <p>5) A = UV 接続は逆接保護</p> <p>B = 入力および出力は逆接保護</p> <p>C = 干渉抑制</p>	<p>1) Сканируемый объект – ремиссия 90 % (относительно стандартного белого по DIN 5033)</p> <p>2) Предельные значения: эксплуатация в защищённой от короткого замыкания сети макс. 8 A; остаточная волнистость макс. 5 Vss</p> <p>3) Продолжительность сигнала при омической нагрузке</p> <p>4) A = UV-подключения с защитой от перепутывания полюсов</p> <p>B = входы и выходы с защитой от перепутывания полюсов</p> <p>C = подавление импульсных помех</p>	